

**MANUAL DE MONTAGEM
ASSEMBLY INSTRUCTIONS
INSTRUCCIONES DE MONTAJE**

COD BR: BPE 16

Sumário Summary Resumen

Introdução Introduction Introducción	3
Antes de começar Before starting Antes de comenzar	4
Evite acidentes Avoid accidents Evitar accidentes	4
Dimensões e ferramentas Dimensions and tools Dimensiones y herramientas	5
Identificação das peças Identifying parts Identificación de las piezas	6
Acessórios incluídos na caixa Hardware included in box Accesorios incluidos en la caja	7
Montagem do móvel Furniture assembly Montaje del mueble	8

Introdução Introduction Introducción

Leia atentamente este manual e siga os passos indicados para que o produto não perca a garantia e também para uma perfeita montagem.

Read this manual and follow the steps in order to keep the guarantee and also for the perfect fit.

Lea este manual y siga los pasos para que el producto no pierda la garantía y también para el ajuste perfecto.

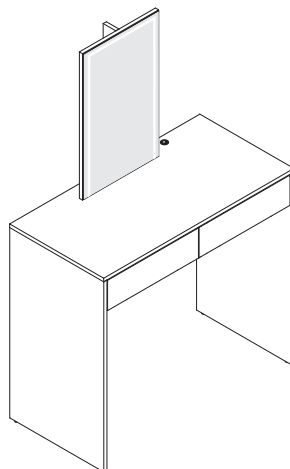

Antes de começar Before starting Antes de comenzar

Antes de começar a montagem prepare o ambiente, deixando-o completamente limpo e com bom espaço para iniciar o trabalho.

Prepare the room before starting the assembly, leaving it completely clean and the area in good condition to start the work.

Antes de comenzar el montaje preparar el ambiente, dejándolo completamente limpio y con bueno espacio para comenzar el trabajo.

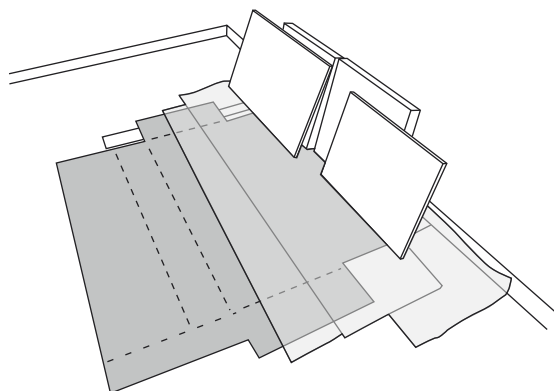

Utilize o papelão da própria embalagem para separar e apoiar as peças retiradas das caixas.

Use the cardboard of the packaging to separate and support the parts removed from the boxes.

Utilice el cartón de la embalaje para separar y apoyar las piezas desmontadas de las cajas.



Forre a área de montagem com um cobertor ou tapete. Assim, você evita avarias nas peças durante o processo de montagem.

Cover the assembly area with a blanket or carpet to avoid damaging the parts during the assembly process.

Cubrir la zona de ensamble con una manta o alfombra. De este modo, se evitan daños en las piezas durante el proceso de montaje.



Evite acidentes Avoid accidents Prevenir accidentes

Solicitamos observar atentamente as orientações de montagem como: fixação do produto na parede, colocação de cola em locais específicos necessários, o peso suportado pelo produto, etc...

We request you to carefully observe the assembly instructions as: fixing the product on the wall, adding glue in needed and specific places, product weight limit, etc.

Pedimos que lea atentamente las instrucciones, principalmente las informaciones de fijación del producto en la pared, colocación de pegamento en local específico y necesario, el peso soportado por el producto etc...

Não escale ou se apoie no móvel.

Do not climb or lean on the furniture.

No se suba ni se apoye en el mueble.

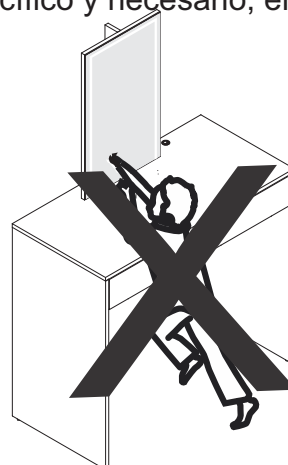

Dimensões e ferramentas
Dimensions and tools
Dimensiones y herramientas

Dimensões:

L: 900 A: 1400 P: 445 mm

Dimensions:

W: 35.43 H: 55.11 D: 17.51 inches

Dimensiones:

L: 900 A: 1400 P: 445 mm

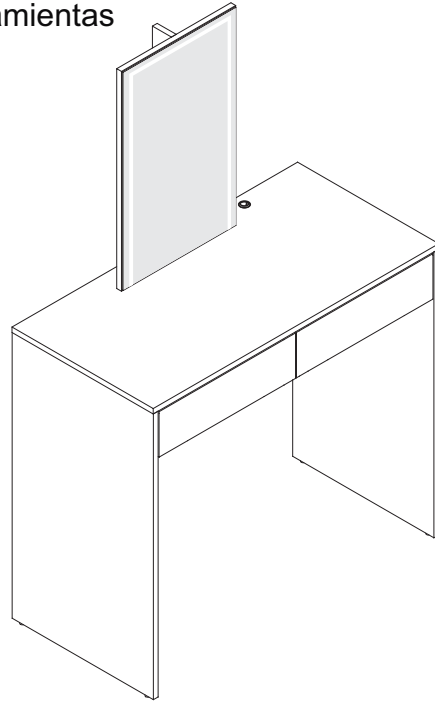

Limpeza
Cleaning
Limpieza

Pano levemente umedecido com água, seguido de pano seco, não utilizar produtos químico ou abrasivos.
You can clean the product with slightly dampened cloth followed by a dry cloth. Do not use chemicals or abrasives.
Solamente utilizar un paño húmedo y después un paño seco, no utilice productos químicos o abrasivos.

Todas as peças do móvel foram marcadas com um número. Antes de começar a montagem, identifique as peças numeradas em relação às instruções de montagem. Uma vez concluída a montagem, os números podem ser facilmente removidos com um pano ligeiramente embebido em álcool. Use álcool apenas para remover números das peças.

All the furniture parts have been marked with a number. Before you start assembling, please identify the numbered parts in relation to the assembly instructions. Once assembly is completed, the numbers can be easily removed with a cloth slightly damped in alcohol. Use alcohol only to remove part numbers.

Todos las piezas del mueble fueron marcadas con un número. Antes de empezar el montaje, identifique las piezas numeradas en relación con las instrucciones de montaje. Una vez que se completa el armado, los números se pueden quitar fácilmente con un paño ligeramente empapado en alcohol. Use alcohol solo para eliminar números de las piezas.

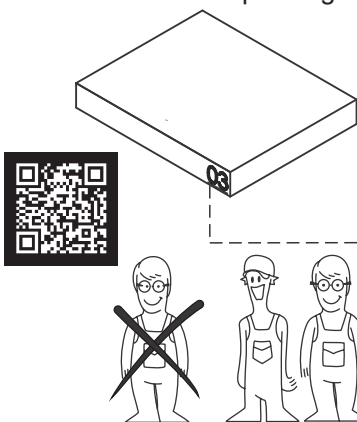

UTILIZE ALCOOL APENAS PARA REMOVER O NUMERO DAS PEÇAS
USE ALCOHOL ONLY TO REMOVE PART NUMBERS
UTILICE ALCOHOL SOLAMENTE PARA ELIMINAR EL NUMERO DE LAS PIEZAS

Para facilitar a montagem, utilize uma parafusadeira elétrica.
To speed assembly, use an electronic screwdriver.
Para facilitar el armado, utilice un destornillador eléctrico.

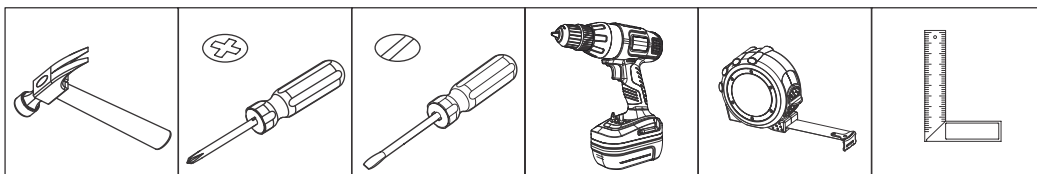

COD BR: BPE 16

PEÇA	DESCRIÇÃO	QUANT.
001	TAMPO	1
002	LATERAL ESQUERDA	1
003	LATERAL DIREITA	1
004	TRAVESSA	1
006	ESPELHO	1
007	TRAVESSA ESPELHO	1
009	COSTA	1
012	DIVISÓRIA	1
013	FRENTE GAVETA ESQUERDA	1
014	FRENTE GAVETA DIREITA	1
015	FUNDO GAVETA	2
020	LATERAL DIREITA GAVETA	2
021	COSTA GAVETA	2
022	LATERAL ESQUERDA GAVETA	2

PART	DESCRIPTION	QTY
001	TOP	1
002	LEFT SIDE	1
003	RIGHT SIDE	1
004	TRAY	1
006	MIRROR	1
007	MIRROR TRAY	1
009	BACK	1
012	PARTITION	1
013	LEFT DRAWER'S FRONT	1
014	RIGHT DRAWER'S FRONT	1
015	DRAWER'S BOTTOM	2
020	DRAWER'S RIGHT SIDE	2
021	DRAWER'S BACK	2
022	DRAWER'S LEFT SIDE	2

PIEZA	DESCRIPCIÓN	CANTIDAD
001	TAPA	1
002	LATERAL IZQUIERDA	1
003	LATERAL DERECHA	1
004	TRAVESAÑO	1
006	ESPEJO	1
007	TRAVESAÑO ESPEJO	1
009	REVÉS	1
012	PARTICIÓN	1
013	FRENTE CAJÓN IZQUIERDO	1
014	FRENTE CAJÓN DERECHO	1
015	FONDO DEL CAJÓN	2
020	LATERAL DERECHA DEL CAJÓN	2
021	REVÉS CAJÓN	2
022	LATERAL IZQUIERDA DEL CAJÓN	2

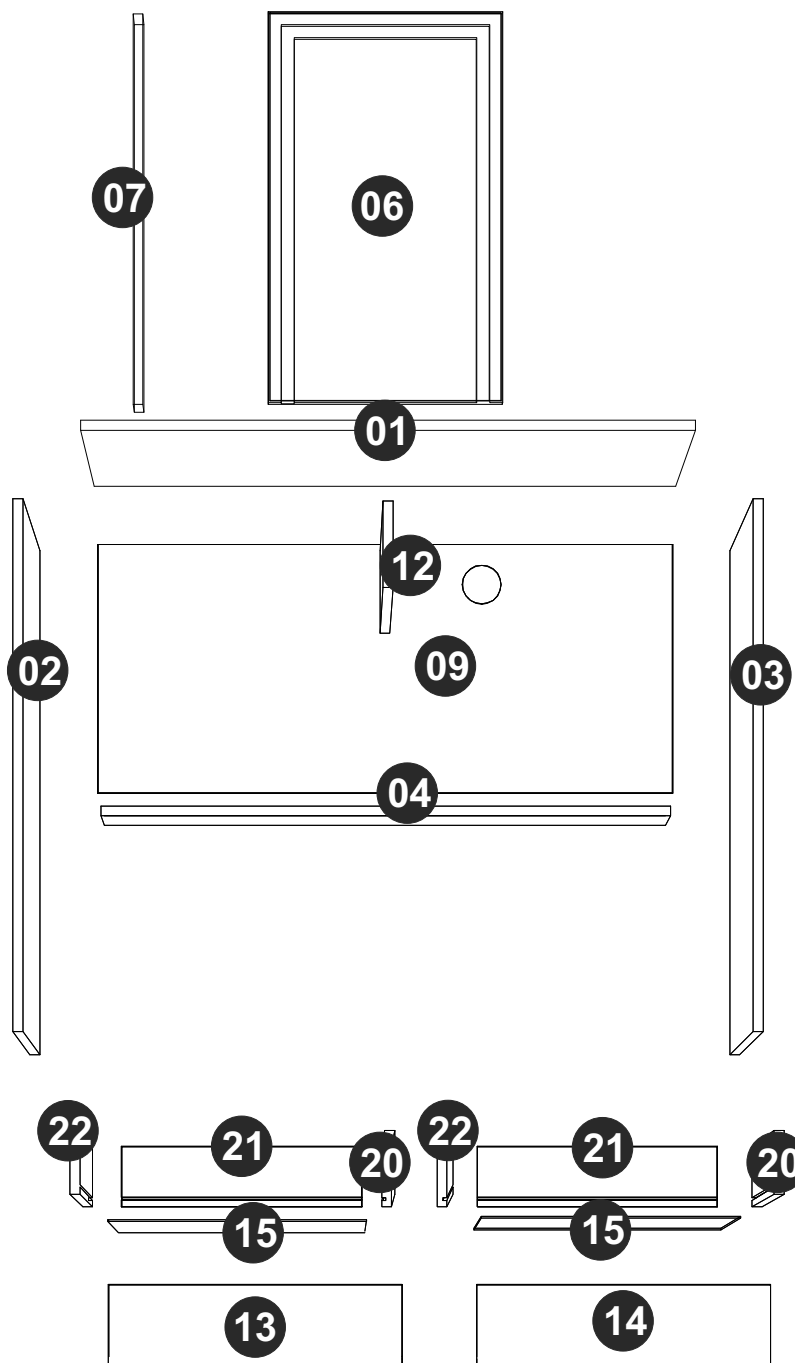



EF 000033 x 25
8x30



EF 000094 X 18



EF 000106 x 12
3,5X14 CC

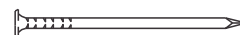

EF 000168 X 30
10x10 C/C



EF 000216 X 18



EF 000132 x 3
4X50 CC



GIZ x 01
CHALK x 01
TIZA x 01

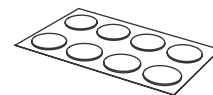

TAPA FUROS x 18
STICKER x 18
TAPAS PLÁSTICAS x 18



EF 000246 X 1
5X50 CF



EF 000248 x 1
3,5x14 CP

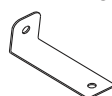

EF 000529 X 1



EF 000016 X 1



EF 000091 x 4
6x8 CC



CORREDIÇAS x 4
DRWER TRACKS x 4
CORREDERAS x 4



PÉS REDONDOS x 4
ROUND FEET x 4
PIES REDONDOS x 4

Utilize para medir as ferragens.

Utilice para medir el herraje.

Use for measuring the hardware.

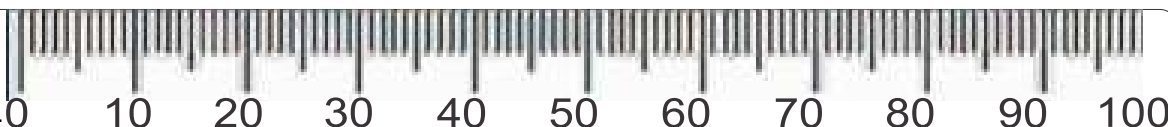

Garantia (exclusivo para o Brasil/exclusivo de Brasil/exclusive to Brazil):

A garantia dos produtos fabricados pela BRV Móveis, abrange eventuais defeitos-vícios de fabricação, no prazo estabelecido pelo código de Defesa do Consumidor, em seu artigo 26.II. o qual prevê a garantia de 90 (noventa) dias.

A = 14 KG - 30.86 LB

B = 2 KG - 4.40 LB

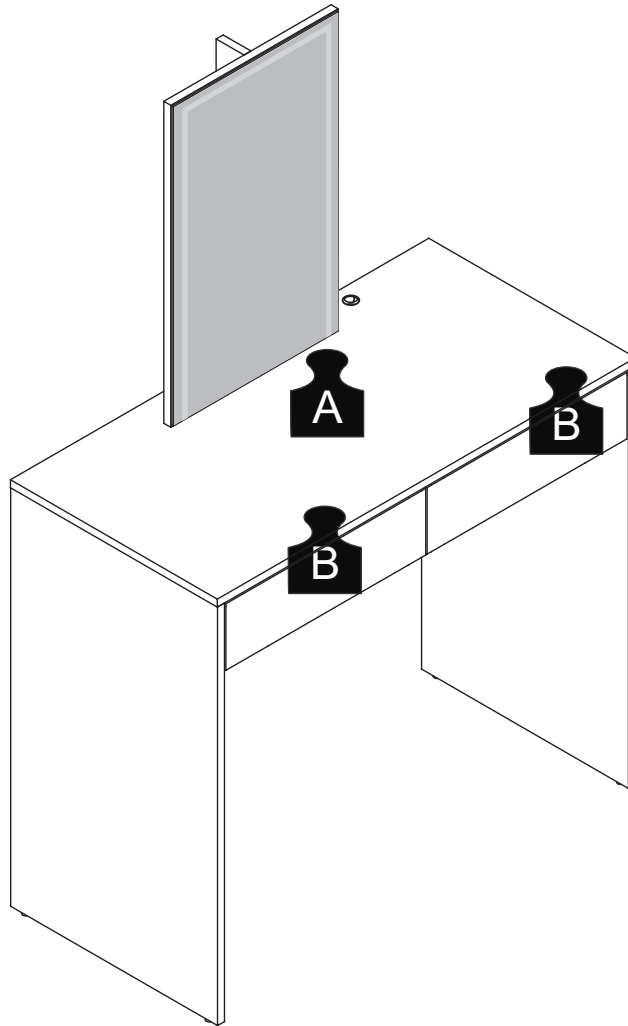

PASSO 1 / STEP 1 / PASO 1

Fixe a ferragem EF 000094 nas peças 01, 13 e 14.
Attach hardware EF 000094 into pieces 01, 13 and 14.
Fije el herraje EF 000094 en las piezas 01, 13 y 14.

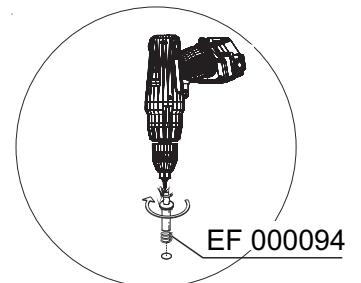
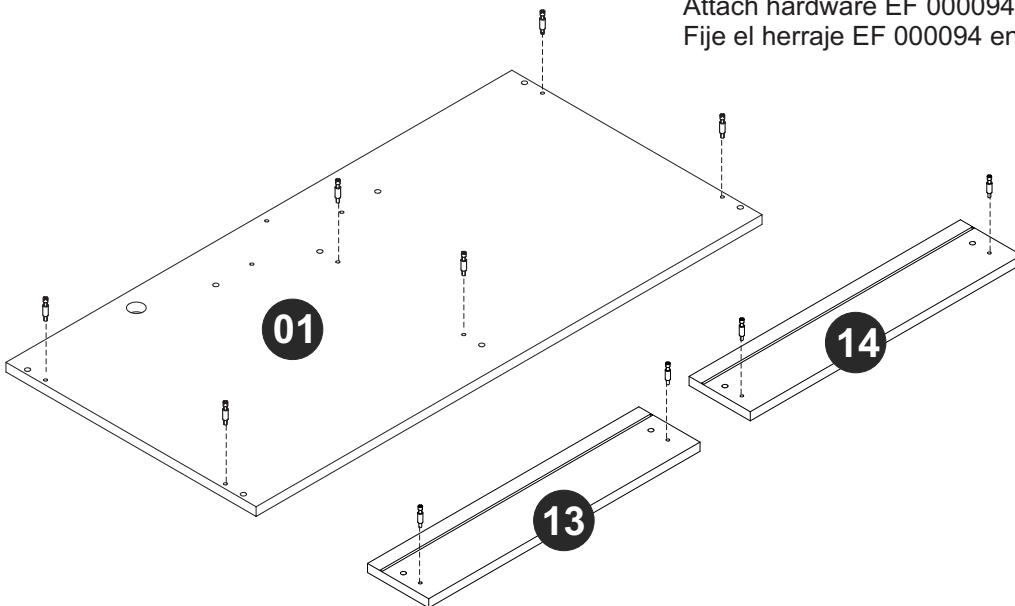

PASSO 2 / STEP 2 / PASO 2

Insira as ferragens EF 000094 e EF 000033 nas peças 20, 21 e 22.

Insert hardware EF 000094 and EF 000033 into pieces 20, 21 and 22.

Añade el herraje EF 000094 y EF 000033 en las piezas 20, 21 y 22.

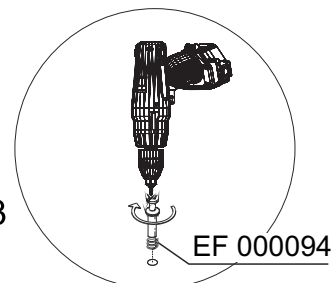
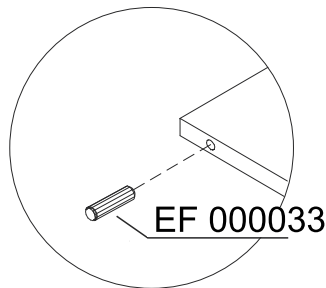
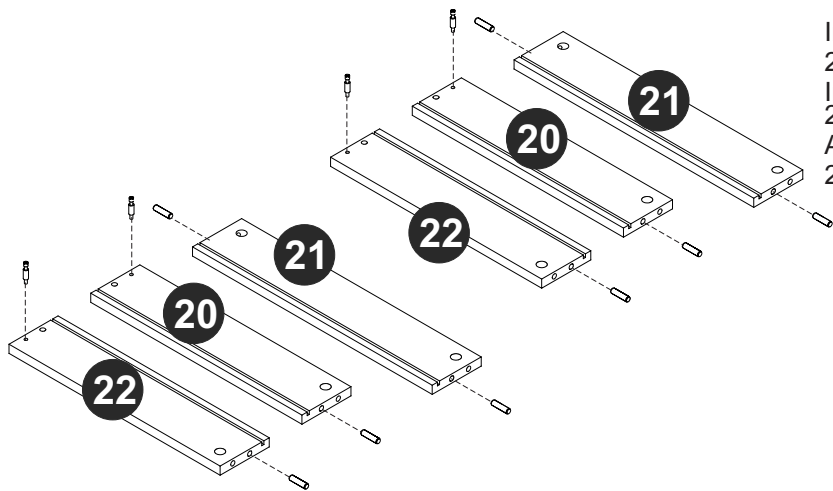

PASSO 3 / STEP 3 / PASO 3

Insira as ferragens EF 000094 e EF 000033 nas peças 02, 03, 06 e 12.

Insert hardware EF 000094 and EF 000033 into pieces 02, 03, 06 and 12.

Añade los herrajes EF 000094 y EF 000033 en las piezas 02, 03, 06 y 12.

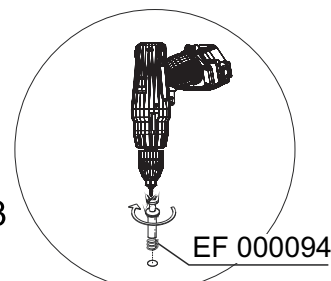
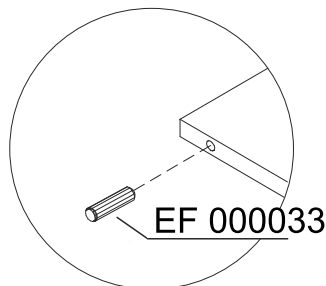
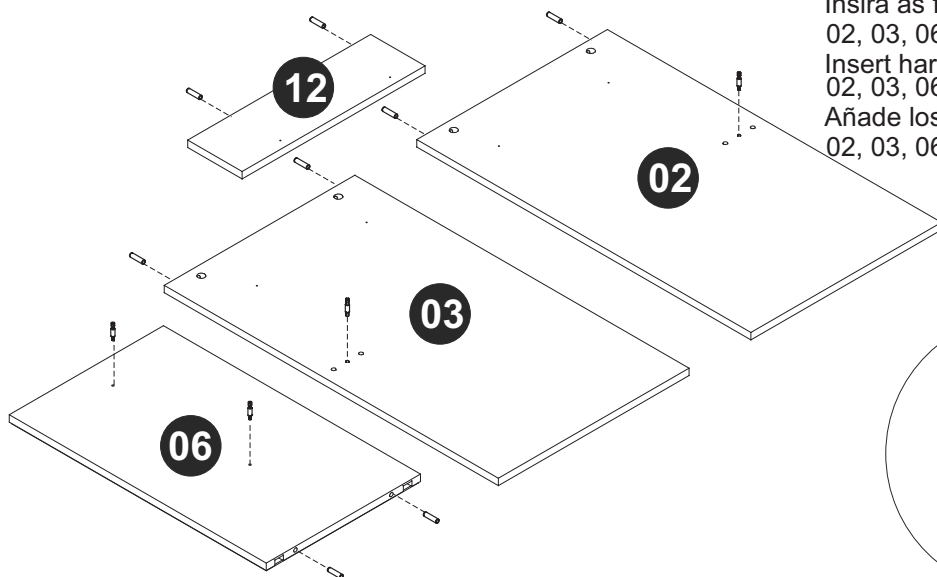

PASSO 4 / STEP 4 / PASO 4

Insira a ferragem EF 000033 nas peças 02, 03 e 12. Fixe a corrediça nas peças 03 e 02 utilizando a ferragem EF 000106.

Insert hardware EF 000033 into pieces 02, 03 and 12. Attach the drawer tracks to pieces 03 and 02 using hardware EF 000106.

Añade el herraje EF 000033 en las piezas 02, 03 y 12. Fije las correderas en las piezas 03 y 02 utilizando el herraje EF 000106.

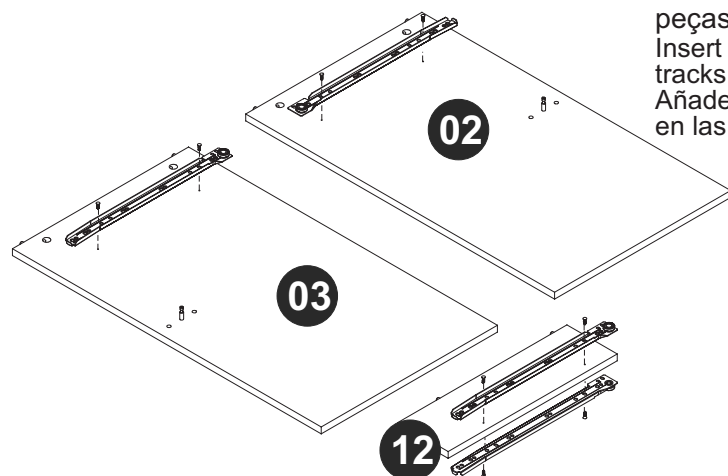

EF 000091 ^{OU} EF 000106

CORREDIÇA
DRAWER TRACKS
CORREDERAS

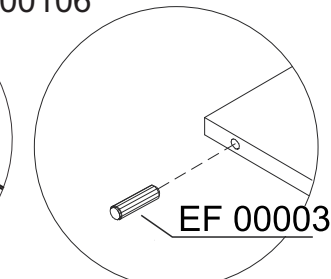
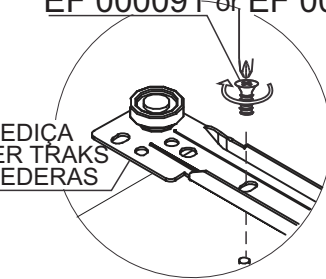

Utilize a ferragem EF 000091 para fixar a corrediça na peça 12.
Use hardware EF 000091 to attach the drawer tracks to piece 12.
Utilice el herraje EF 000091 para fijar las correderas a la pieza 12.



PASSO 5 / STEP 5 / PASO 5

Insira as ferragens EF 000033 nas peças 04 e 07.
Insert hardware EF 000033 into pieces 04 and 07.
Añade el herraje EF 000033 en las piezas 04 y 07.

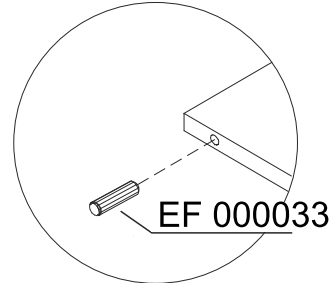
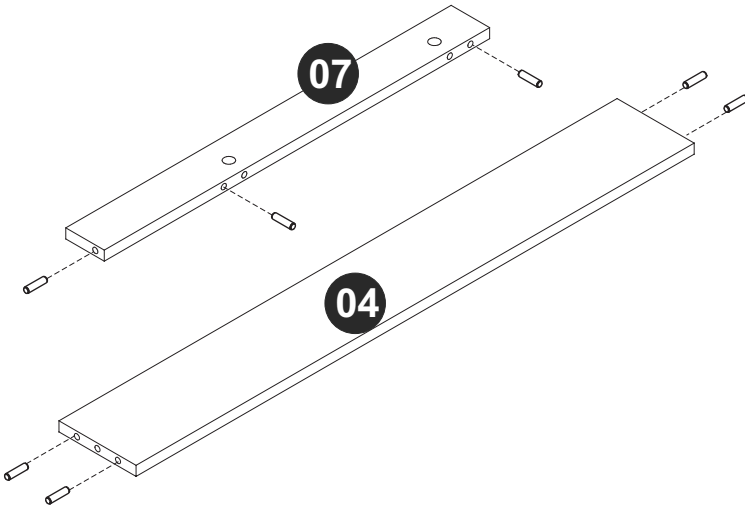

PASSO 6 / STEP 6 / PASO 6

Conecte as peças 06 e 07 insira a ferragem EF 000216 e gire para apertar.
Connect pieces 06 and 07, insert hardware EF 000216 and turn to tighten.
Junte las piezas 06 y 07, añade el herraje EF 000216 y gire para apretar.

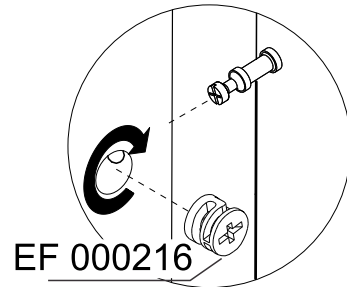
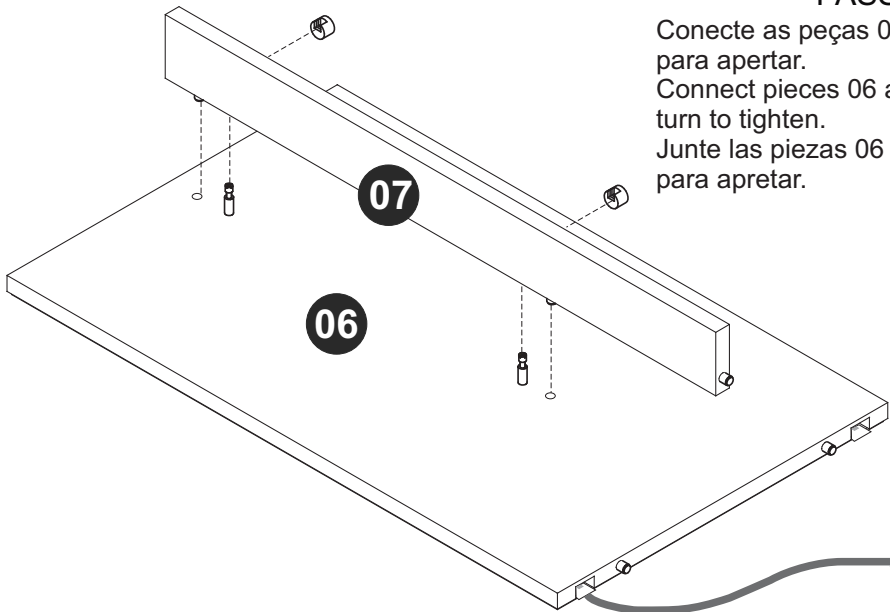

PASSO 7 / STEP 7 / PASO 7

Fixe as peças 01, 06 e 07 utilizando a ferragem EF 000132.
Attach pieces 01, 06 and 07 using hardware EF 000132.
Fije las piezas 01, 06 y 07 utilizando el herraje EF 000132.

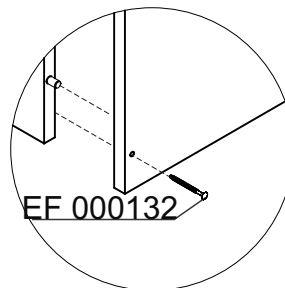
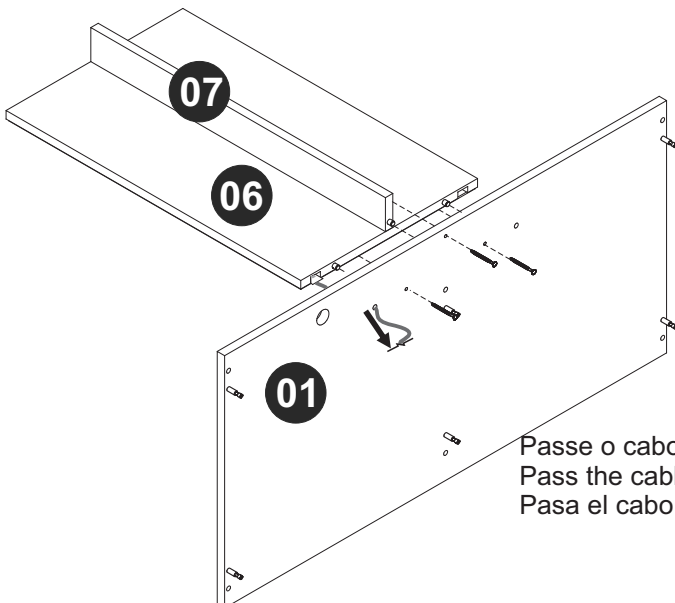

Passe o cabo que sai do canto do espelho pelo menor furo na peça 01.
Pass the cable that comes out from the mirror through the smallest hole in piece 01.
Pasa el cabo que sale del canto del espejo por el menor hueco de la pieza 01

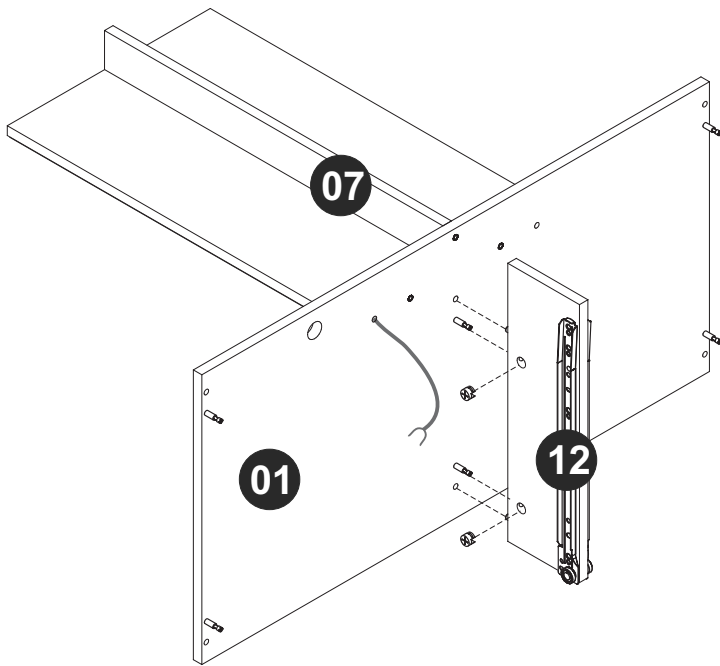

PASSO 8 / STEP 8 / PASO 8

Conecte as peças 01 e 12, insira a ferragem EF 000216 e gire para apertar.
 Connect pieces 01 and 12, insert hardware EF 000216 and turn to tighten.
 Junte las piezas 01 y 12, añada el herraje EF 000216 y gire para apretar.

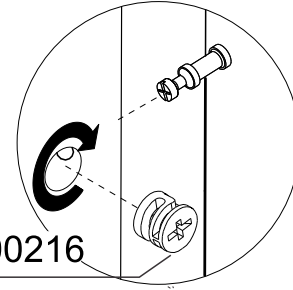

EF 000216

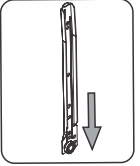

Por favor, note a posição da corrediça.
 Please, note the drawer tracks position.
 Por favor notar la posición de las correderas.

PASSO 9 / STEP 9 / PASO 9

Conecte as peças 02, 03 e 04, insira a ferragem EF 000216 e gire para apertar.
 Connect pieces 02, 03 and 04, insert hardware EF 000216 and turn to tighten.
 Junte las piezas 02, 03 y 04, añada el herraje EF 000216 y gire para apretar.

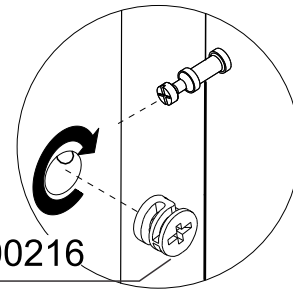
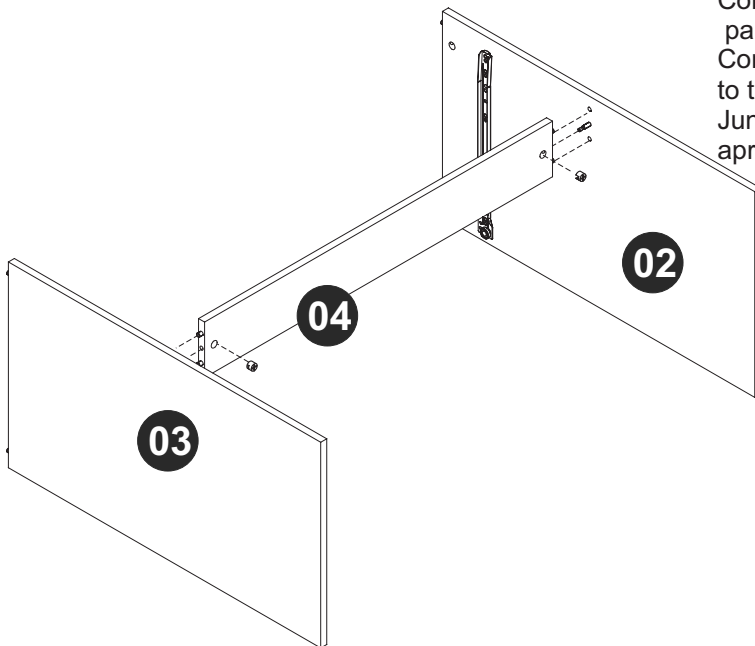

EF 000216

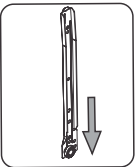

Por favor, note a posição da corrediça.
 Please, note the drawer tracks position.
 Por favor notar la posición de las correderas.

PASSO 10 / STEP 10 / PASO 10

Conecte as peças 02 e 03, insira a ferragem EF 000216 e gire para apertar.
 Connect pieces 02 and 03, insert hardware EF 000216 and turn to tighten.
 Junte las piezas 02 y 03, añada el herraje EF 000216 y gire para apretar.

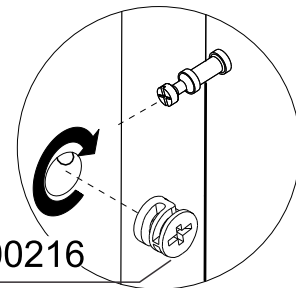
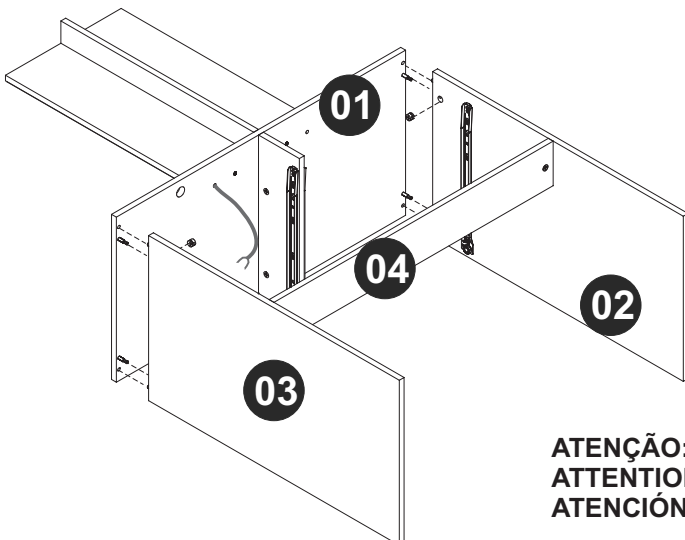

EF 000216

ATENÇÃO: Leia as instruções do manual LED para a instalação.
ATTENTION: Read LED instruction manual for installing.
ATENCIÓN: Lea las instrucciones del manual LED para la instalación.

PASSO 11 / STEP 11/ PASO 11

Fixe a peça 09 e os pés ao móvel utilizando a ferragem EF 000168.
Attach piece 09 and the feet at the furniture using hardware EF 000168.
Fije las piezas 09 y los pies al mueble utilizando el herraje EF 000168.

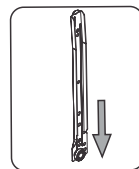
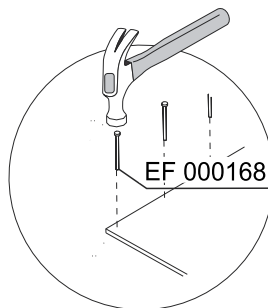
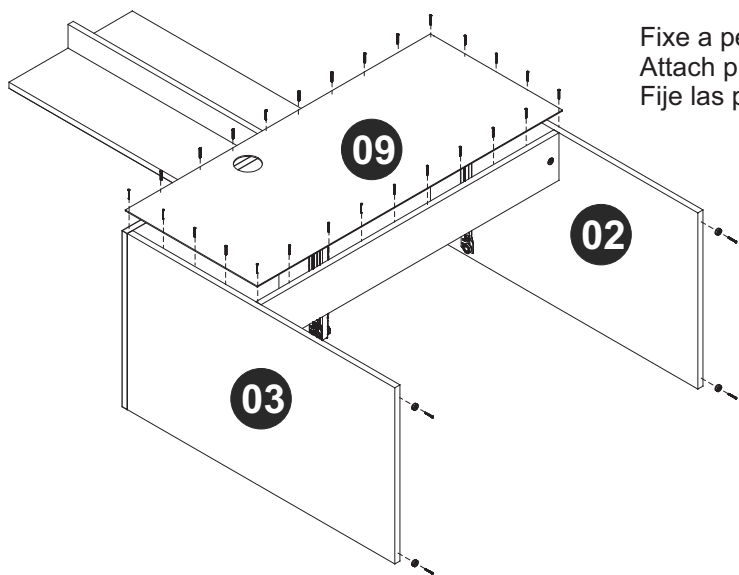

Por favor, note a posição da corredeira.
Please, note the drawer tracks position.
Por favor notar la posición de las correderas.

PASSO 12 / STEP 12 / PASO 12

Conecte as peças 20, 21 e 22, insira a ferragem EF 000216 e gire para apertar.
Connect pieces 20, 21 and 22, insert hardware EF 000216 and turn to tighten.
Junte las piezas 20, 21 y 22, añade el herraje EF 000216 y gire para apretar.

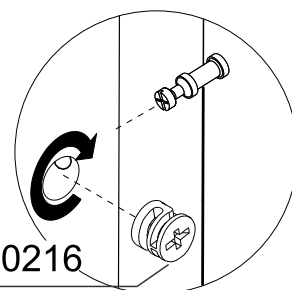
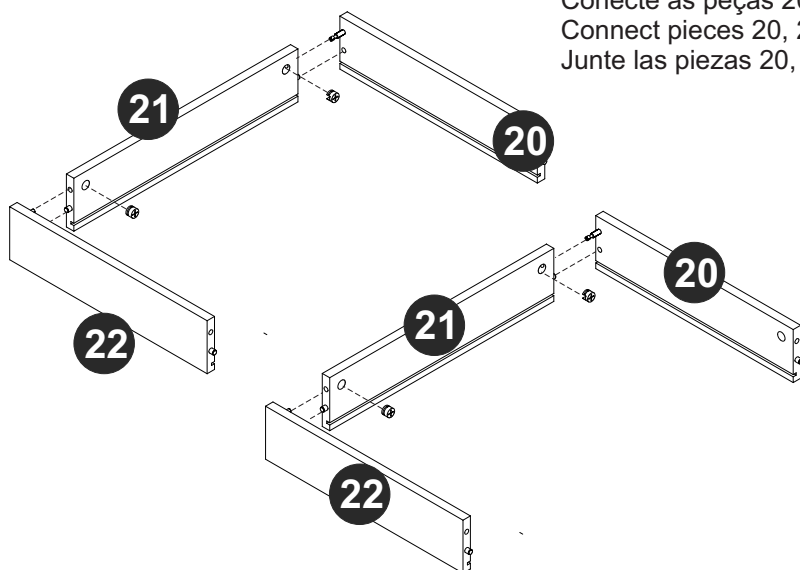

EF 000216

PASSO 13 / STEP 13 / PASO 13

Encaixe a peça 15 entre os espaços específicos nas peças 20 e 22.
Fit piece 15 through the specific spaces in pieces 20 and 22.
Añade la pieza 15 entre los espacios específicos en las piezas 20 y 22.

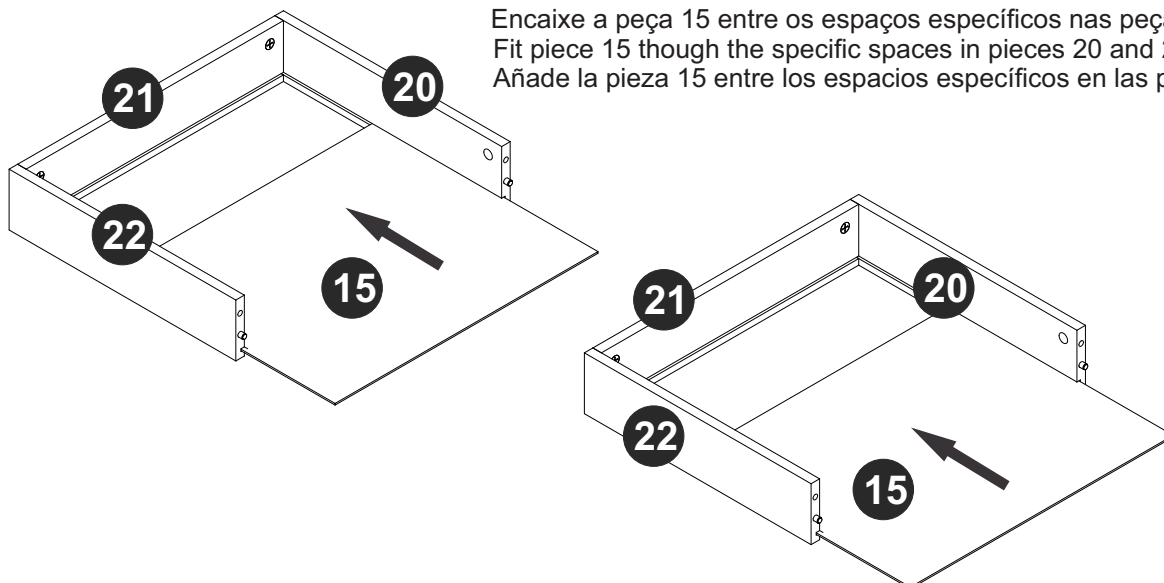

PASSO 14 / STEP 14/ PASO 14

Conecte as peças 13 e 14, insira a ferragem EF 000216 e gire para apertar.
Fixe o puxador utilizando a ferragem EF 000791.
Connect pieces 13 and 14, insert hardware EF 000216 and turn to tighten.
Attach the handle using hardware EF 000791.
Junte las piezas 13 y 14, añada el herraje EF 000216 y gire para apretar.
Fije la manija utilizando el herraje EF 000791.

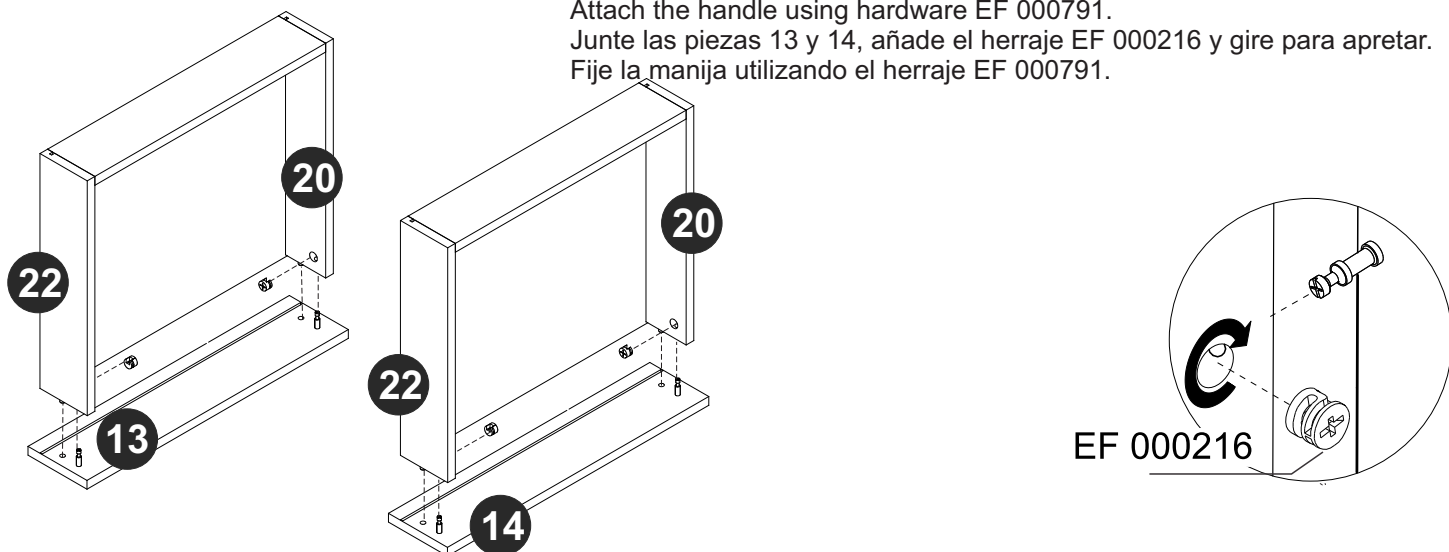

PASSO 15 / STEP 15 / PASO 15

Fixe as correijas de acordo com a imagem.
Attach the drawer tracks according the image.
Fije las correderas de acuerdo con la imagen.

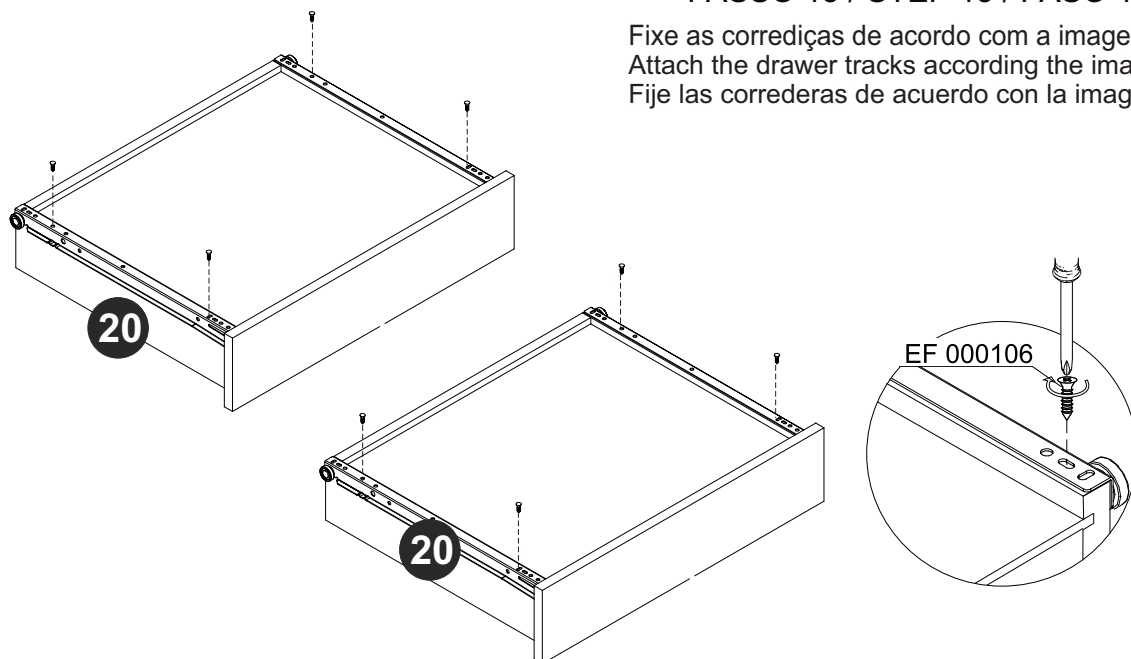

PASSO 16 / STEP 16 / PASO 16

Use o parafuso EF 000248 para fixar a ferragem EF 000529 ao móvel.
Use hardware EF 000248 to fix the hardware EF 000529 to the furniture.
Utilice el herraje EF 000248 para fijar el herraje EF000529 al mueble.

Use as ferragens EF 000246 e EF 000016 para fixar o móvel na parede.
Use hardwares EF 000246 and EF 000016 for fixing the furniture to the wall.
Utilice los herrajes EF000246 y EF000016 para fijar el mueble en la pared.

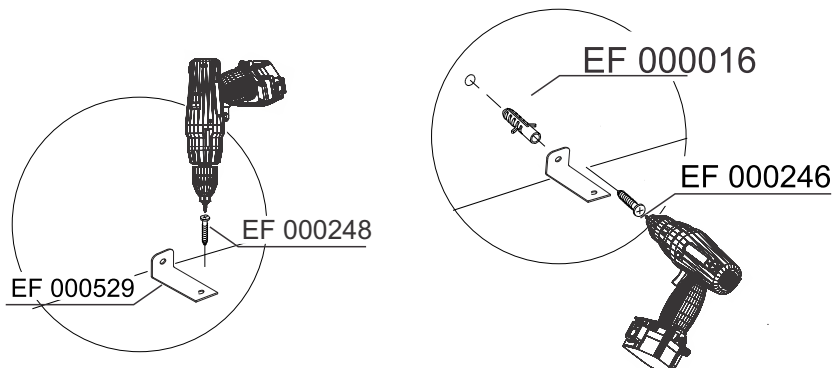
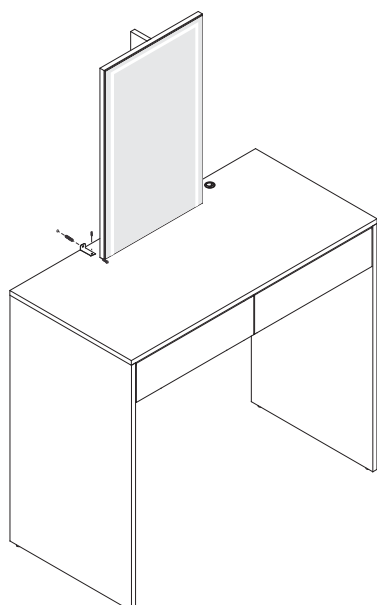

PASSO 17 / STEP 17/ PASO 17

Utilize o tapa furos para cobrir os parafusos aparentes.
Use the sticker to cover the apparent screws.
Utilice los tapa huecos para cubrir los tornillos aparentes.

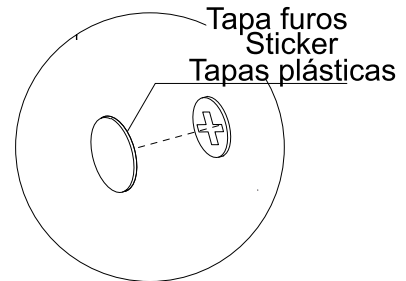
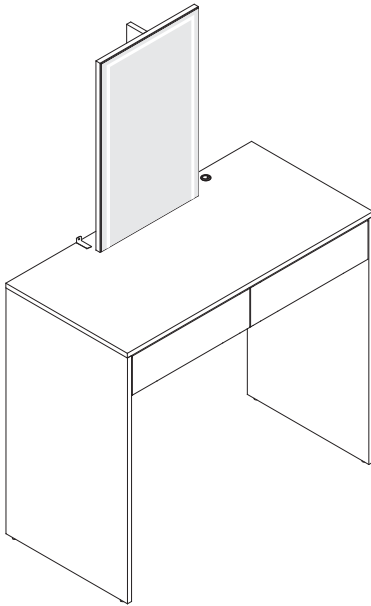

PASSO 18 / STEP 18 / PASO 18

Utilize o giz para dar o acabamento final ao produto.
Use the chalk to give the final finish on the product.
Utilize la tiza para dar el acabado final al producto.

