



MANUAL DE MONTAGEM
ASSEMBLY INSTRUCTIONS
INSTRUCCIONES DE MONTAJE

COD BR: BCR 11

Sumário Summary Resumen

Introdução Introduction Introducción	3
Antes de começar Before starting Antes de comenzar	4
Evite acidentes Avoid accidents Evitar accidentes	4
Dimensões e ferramentas Dimensions and tools Dimensiones y herramientas	5
Identificação das peças Identifying parts Identificación de las piezas	6
Acessórios incluídos na caixa Hardware included in box Accesorios incluidos en la caja	7
Montagem do móvel Furniture assembly Montaje del mueble	8

Introdução Introduction Introducción

Leia atentamente este manual e siga os passos indicados para que o produto não perca a garantia e também para uma perfeita montagem.

Read this manual and follow the steps in order to keep the guarantee and also for the perfect fit.

Lea este manual y siga los pasos para que el producto no pierda la garantía y también para el ajuste perfecto.

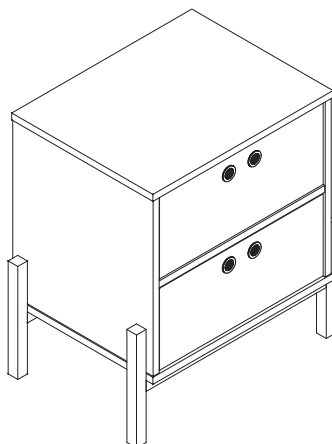

Antes de começar Before starting Antes de comenzar

Antes de começar a montagem prepare o ambiente, deixando-o completamente limpo e com bom espaço para iniciar o trabalho.

Prepare the room before starting the assembly, leaving it completely clean and the area in good condition to start the work.

Antes de comenzar el montaje preparar el ambiente, dejándolo completamente limpio y con bueno espacio para comenzar el trabajo.

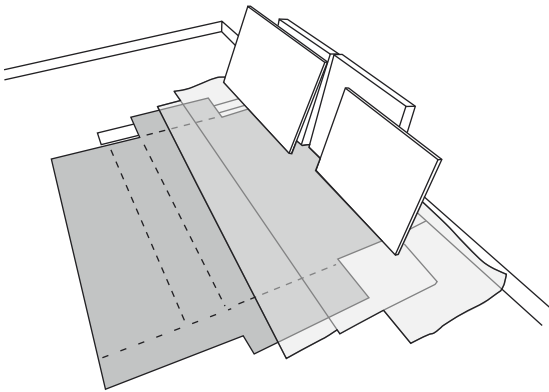

Utilize o papelão da própria embalagem para separar e apoiar as peças retiradas das caixas.

Use the cardboard of the packaging to separate and support the parts removed from the boxes.

Utilice el cartón de la embalaje para separar y apoyar las piezas desmontadas de las cajas.

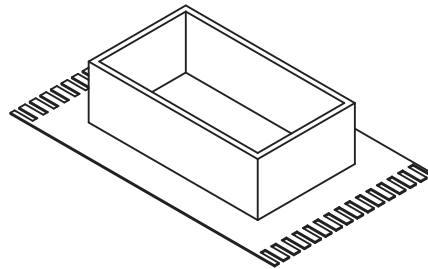

Forre a área de montagem com um cobertor ou tapete. Assim, você evita avarias nas peças durante o processo de montagem.

Cover the assembly area with a blanket or carpet to avoid damaging the parts during the assembly process.

Cubrir la zona de ensamble con una manta o alfombra. De este modo, se evitan daños en las piezas durante el proceso de montaje.



Evite acidentes Avoid accidents Prevenir accidentes

Solicitamos observar atentamente as orientações de montagem como: fixação do produto na parede, colocação de cola em locais específicos necessários, o peso suportado pelo produto, etc...

We request you to carefully observe the assembly instructions as: fixing the product on the wall, adding glue in needed and specific places, product weight limit, etc.

Pedimos que lea atentamente las instrucciones, principalmente las informaciones de fijación del producto en la pared, colocación de pegamento en local específico y necesario, el peso soportado por el producto etc...

Não escale ou se apoie no móvel.

Do not climb or lean on the furniture.

No se suba ni se apoye en el mueble.

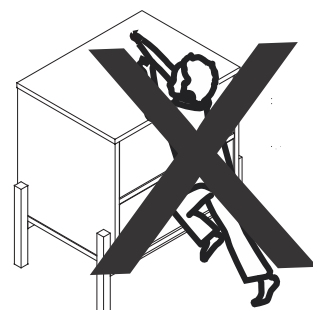

Dimensões e ferramentas
Dimensions and tools
Dimensiones y herramientas

Dimensões:
L: 500 A: 545 P: 350 mm
Dimensions:
W: 19.68 H: 21.45 D: 13.77 inches
Dimensiones:
L: 500 A: 545 P: 350 mm

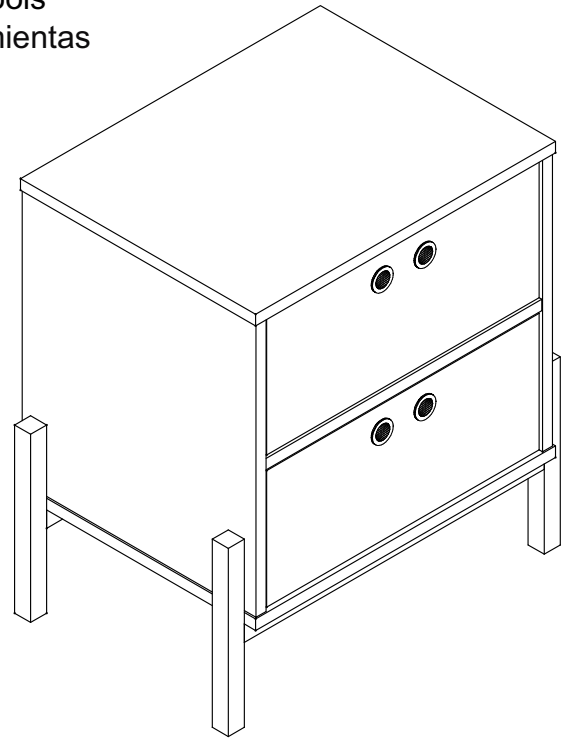

Limpeza
Cleaning
Limpieza

Pano levemente umedecido com água, seguido de pano seco, não utilizar produtos químico ou abrasivos.
You can clean the product with slightly dampened cloth followed by a dry cloth. Do not use chemicals or abrasives.
Solamente utilizar un paño húmedo y después un paño seco, no utilice productos químicos o abrasivos.

Todas as peças do móvel foram marcadas com um número. Antes de começar a montagem, identifique as peças numeradas em relação às instruções de montagem. Uma vez concluída a montagem, os números podem ser facilmente removidos com um pano ligeiramente embebido em álcool. Use álcool apenas para remover números das peças.

All the furniture parts have been marked with a number. Before you start assembling, please identify the numbered parts in relation to the assembly instructions. Once assembly is completed, the numbers can be easily removed with a cloth slightly damped in alcohol. Use alcohol only to remove part numbers.

Todos las piezas del mueble fueron marcadas con un número. Antes de empezar el montaje, identifique las piezas numeradas en relación con las instrucciones de montaje. Una vez que se completa el armado, los números se pueden quitar fácilmente con un paño ligeramente empapado en alcohol. Use alcohol solo para eliminar números de las piezas.

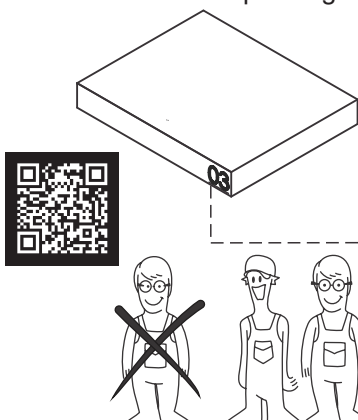

UTILIZE ALCOOL APENAS PARA REMOVER O NUMERO DAS PEÇAS
USE ALCOHOL ONLY TO REMOVE PART NUMBERS
UTILICE ALCOHOL SOLAMENTE PARA ELIMINAR EL NUMERO DE LAS PIEZAS

Para facilitar a montagem, utilize uma parafusadeira elétrica.
To speed assembly, use an electronic screwdriver.
Para facilitar el armado, utilice un destornillador eléctrico.

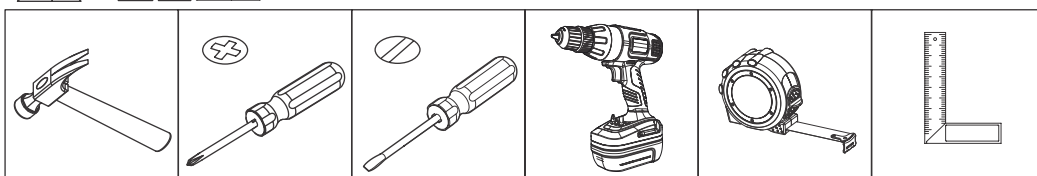

COD BR: BCR 11

PEÇA	DESCRIÇÃO	QUANTIDADE.
001	BASE	1
002	TAMPO	1
003	LATERAL ESQUERDA	1
004	LATERAL DIREITA	1
005	FRENTE GAVETA	2
006	TRAVESSA	1
007	FUNDO GAVETA	2
008	COSTA	2
009	PÉS	2
020	LATERAL DIREITA GAVETA	2
021	COSTA GAVETA	2
022	LATERAL ESQUERDA GAVETA	2

PART	DESCRIPTION	QTY
001	BASE	1
002	TOP	1
003	LEFT SIDE	1
004	RIGHT SIDE	1
005	DRAWER'S FRONT	2
006	TRVERSE	1
007	DRAWER'S BOTTOM	2
008	BACK	2
009	FEET	2
020	DRAWER'S RIGHT SIDE	2
021	DRAWER'S BACK	2
022	DRAWER'S LEFT SIDE	2

PIEZA	DESCRIPCIÓN	CANTIDAD
001	BASE	1
002	TAPA	1
003	LATERAL IZQUIERDA	1
004	LATERAL DERECHA	1
005	FRENTE CAJÓN	2
006	TRAVESAÑO	1
007	FONDO CAJÓN	2
008	REVÉS	2
009	PIÉS	2
020	LATERAL DERECHA CAJÓN	2
021	REVÉS CAJÓN	2
022	LATERAL IZQUIERDA CAJÓN	2

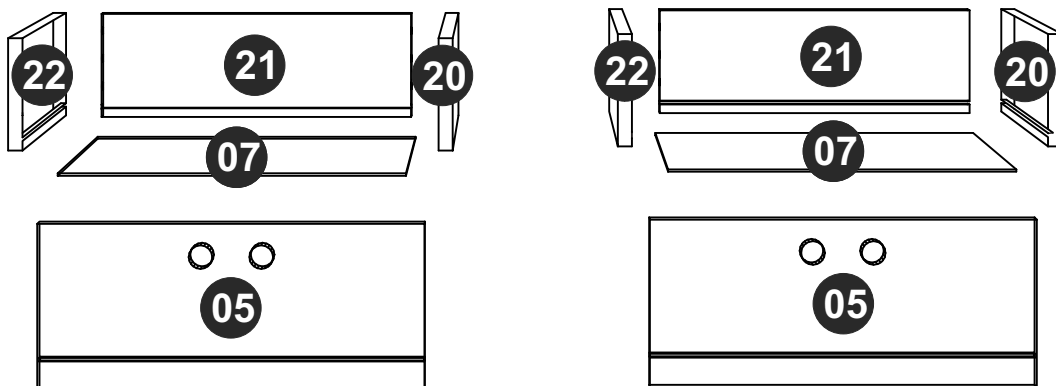
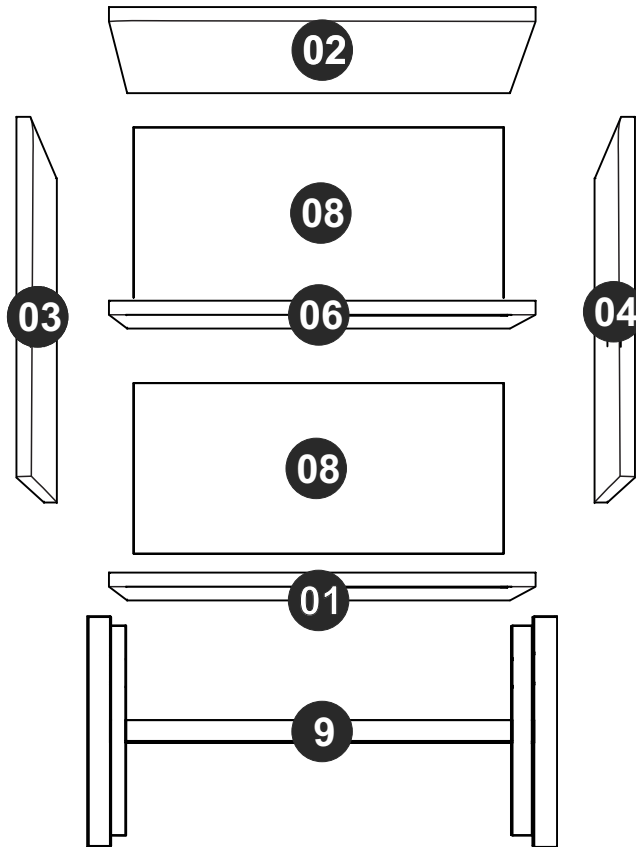



EF 000033x 28
8x30

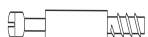

EF 000094 X 12



EF 000106 X 16
3,5x14 CC



EF 000136 x 8
4,5X35 CC



EF 000132 x 4
4X50 CC



EF 000168 X 18
10x10 C/C



EF 000216 X 12



PUXADOR x 4
HANDLE x 4
MANIJA x 4



CORREDIÇA x 4
DRAWER TRAKS x 4
CORREDERAS x 4



GIZ x 01
CHALK x 01
TIZA x 01

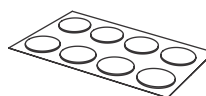

TAPA FUROS x 20
STICKER x 20
TAPAS PLÁSTICAS x 20

Utilize para medir as ferragens.

Utilice para medir el herraje.

Use for measuring the hardware.

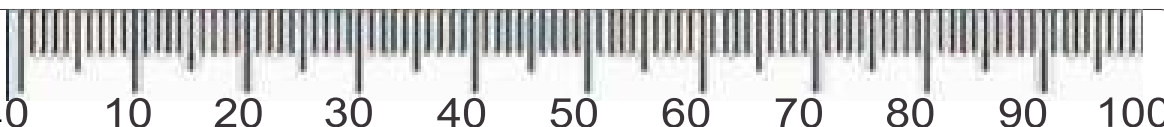

Garantia (exclusivo para o Brasil/exclusivo de Brasil/exclusive to Brazil):

A garantia dos produtos fabricados pela BRV Móveis, abrange eventuais defeitos-vícios de fabricação, no prazo estabelecido pelo código de Defesa do Consumidor, em seu artigo 26.II. o qual prevê a garantia de 90 (noventa) dias.

A = 5 KG - 11.02 LB

B = 2 KG - 4.40 LB

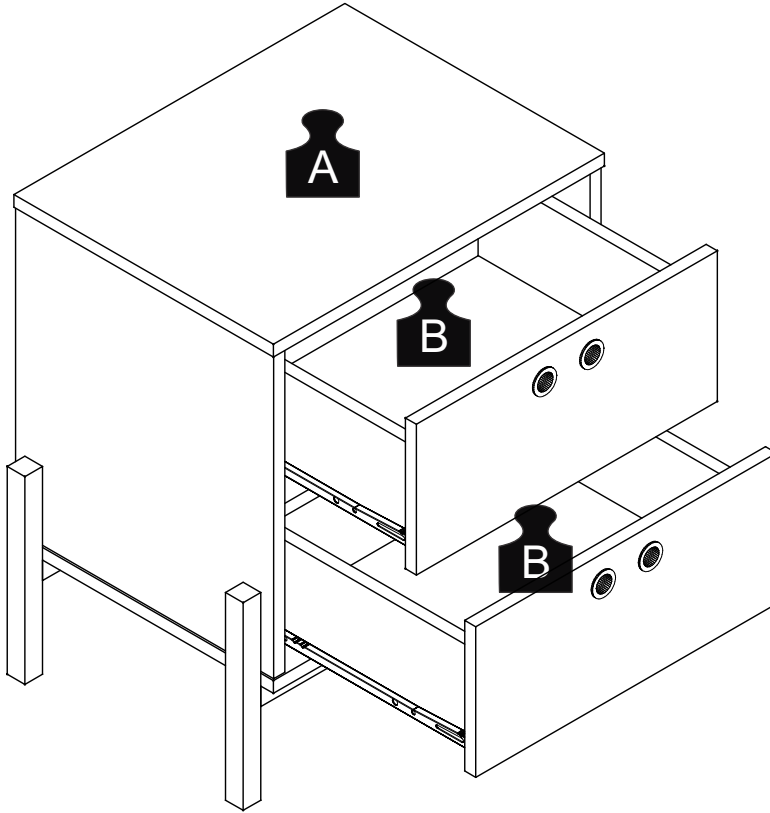

PASSO 1 / STEP 1 / PASO 1

Fixe a ferragem EF 000094 nas peças 02, 05, 20 e 22.
Attach hardware EF 000094 into pieces 02, 05, 20 and 22.
Fije el herraje EF 000094 en las piezas 02, 05, 20 y 22.

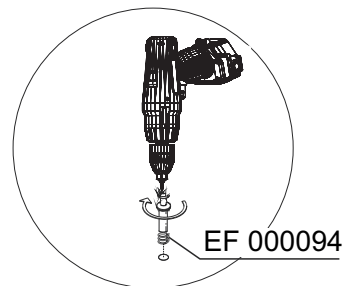
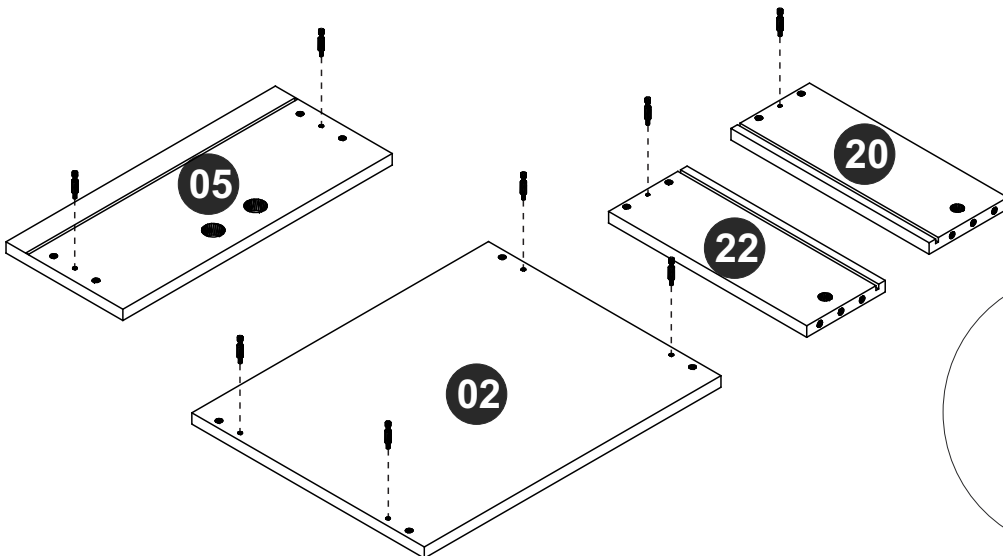

PASSO 2 / STEP 2 / PASO 2

Insira a ferragem EF 000033 nas peças 06, 20, 21 e 22.
Insert hardware EF 000033 into pieces 06, 20, 21 and 22.
Añade el herraje EF 000033 en las piezas 06, 20, 21 y 22.

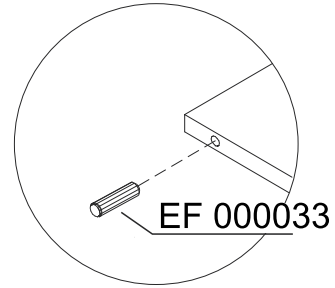
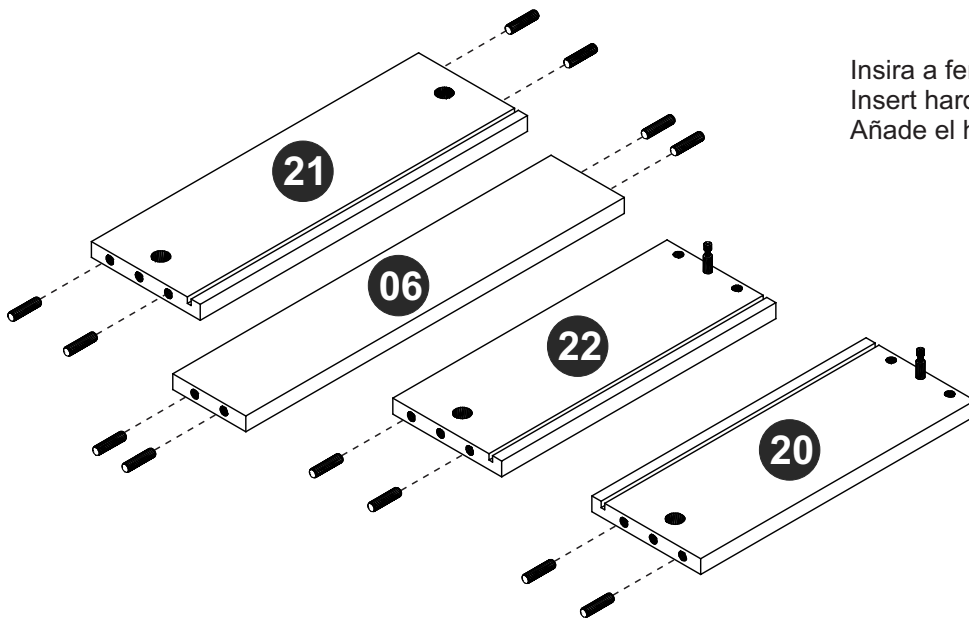

PASSO 3 / STEP 3 / PASO 3

Insira a ferragem EF 000033 nas peças 03 e 04. Fixe as
corrediças utilizando a ferragem EF 000106.
Insert hardware EF 000033 into pieces 03 e 04. Attach
the drawer tracks using hardware EF 000106.
Añade el herraje EF 000033 en las piezas 03 e 04. Fije las
correderas utilizando el herraje EF 000106.

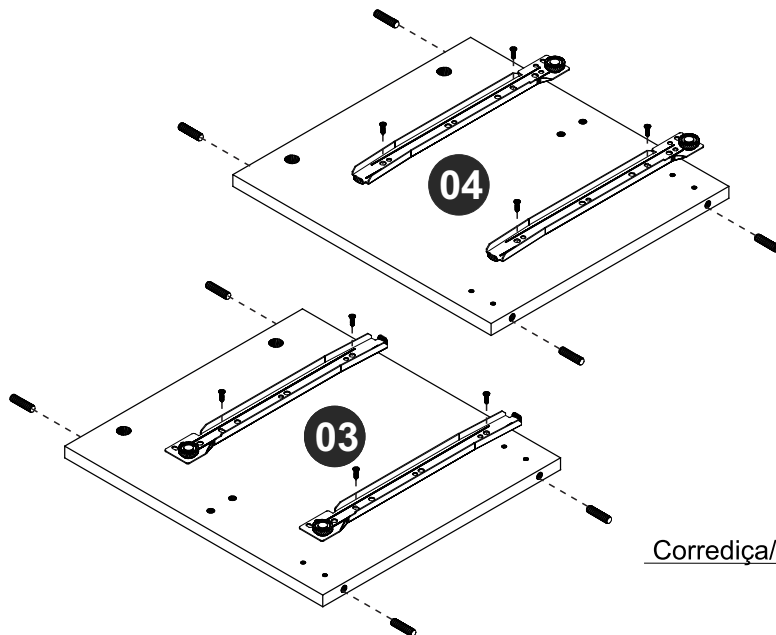

Corrediça/Corredera/Drawer tracks

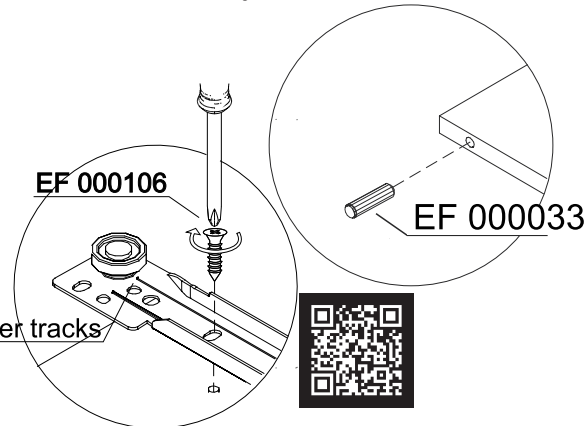

PASSO 4 / STEP 4/ PASO 4

Conecte as peças 03, 04 e 06
Connect pieces 03, 04 and 06
Junte las piezas 03, 04 y 06

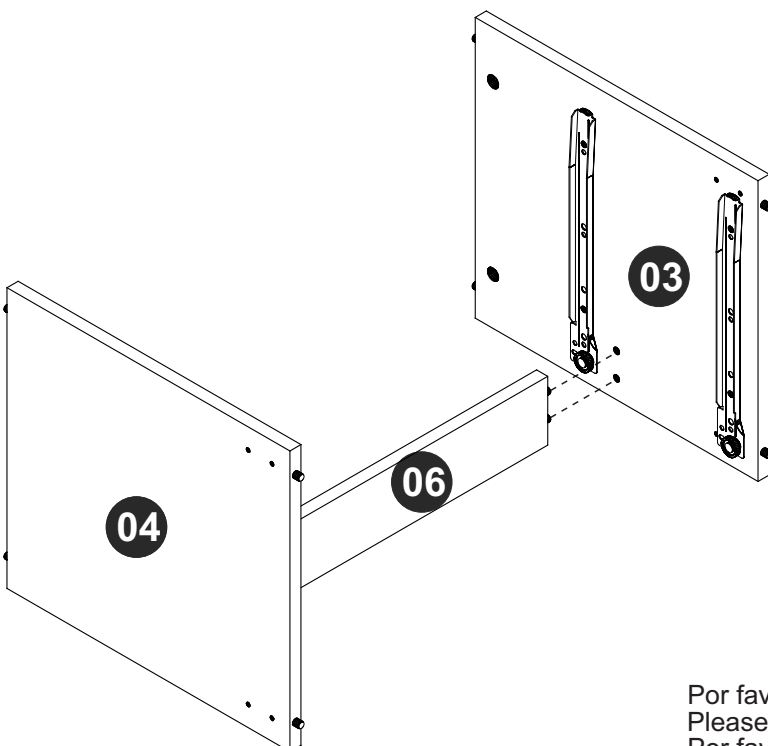

Por favor, note a posição das corrediças
Please, note the drawer tracks position
Por favor, notar la posición de las correderas

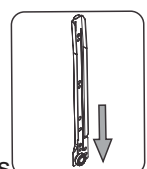

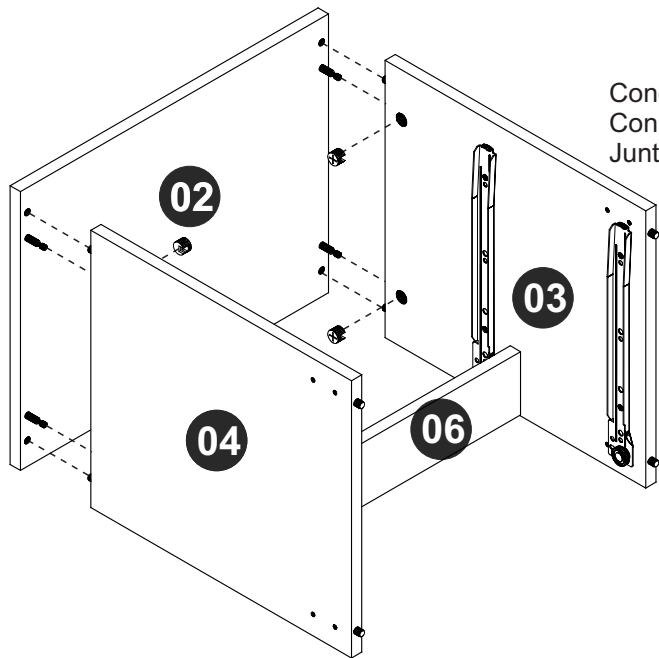

PASSO 5 / STEP 5 / PASO 5

Conecte as peças 03, 04 e 02, insira a ferragem EF 000216 e gire para apertar.
 Connect pieces 03, 04 and 02, insert hardware EF 000216 and turn to tighten.
 Junte las piezas 03, 04 y 02, añade el herraje EF 000216 y gire para apretar.

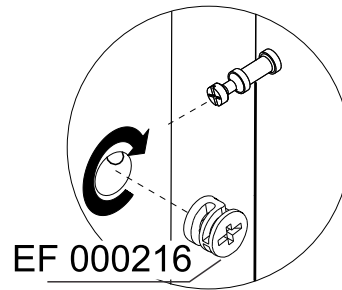

Por favor, note a posição das corredeiras
 Please, note the drawer tracks position
 Por favor, notar la posición de las correderas

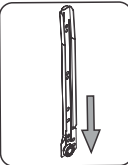

PASSO 6 / STEP 6 / PASO 6

Conecte as peças 03, 04 e 01 utilizando a ferragem EF 000132.
 Connect pieces 03, 04 and 01 using hardware EF 000132.
 Junte las piezas 03, 04 y 01 utilizando el herraje EF 000132.

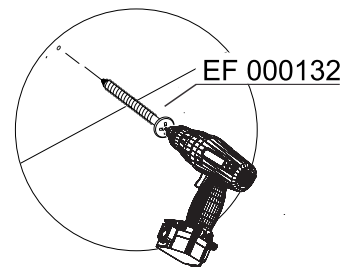
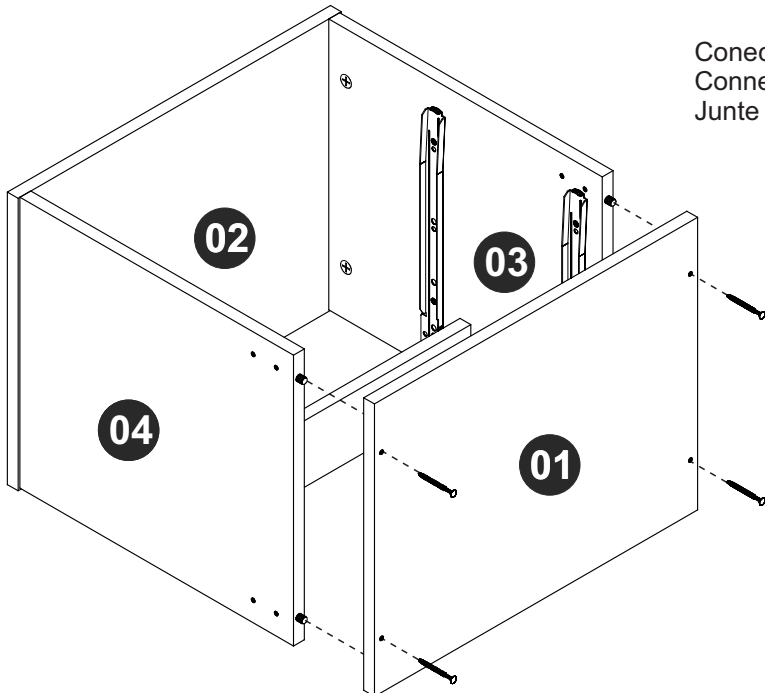

Por favor, note a posição das corredeiras
 Please, note the drawer tracks position
 Por favor, notar la posición de las correderas

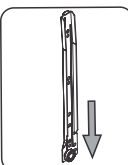

PASSO 7 / STEP 7 / PASO 7

Fixe os pés (peças 09) à parte montada no passo anterior usando a ferragem EF 000136.
 Fix the feet (pieces 09) to the part assembled in the previous step using hardware EF 000136.
 Fije los pies (piezas 09) a la parte armada en el paso anterior utilizando el herraje EF 000136.

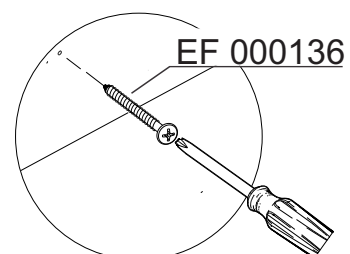
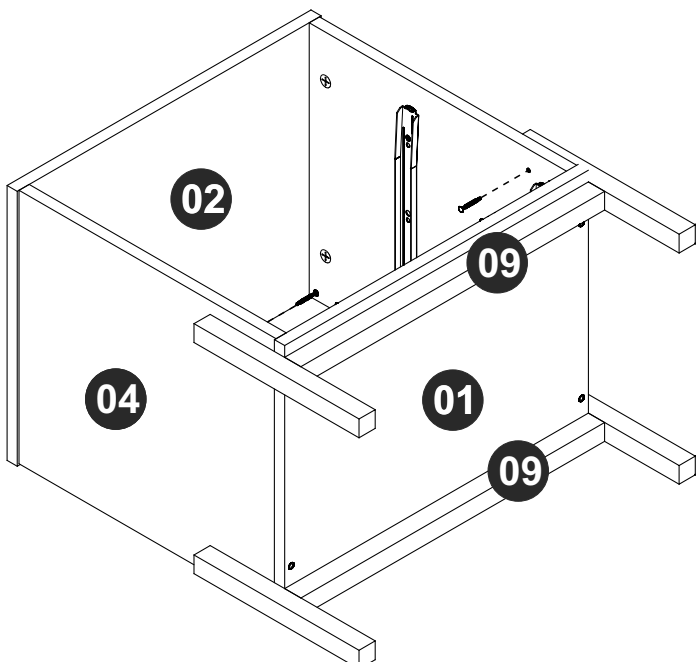

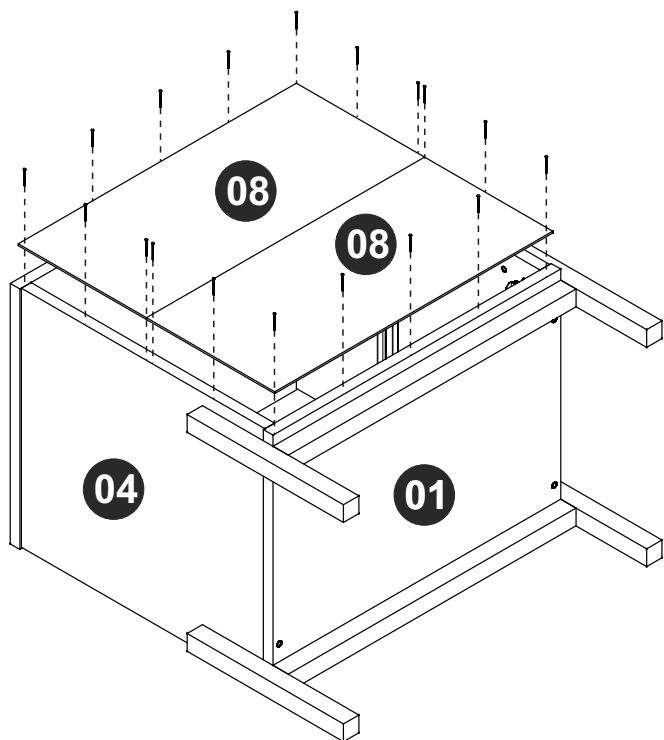

PASSO 8 / STEP 8/ PASO 8

Fixe as peças 08 ao móvel utilizando a ferragem EF 000168.
 Fix pieces 08 at the furniture using hardware EF 000168.
 Fije las piezas 08 al mueble utilizando el herraje EF 000168.

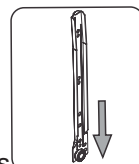
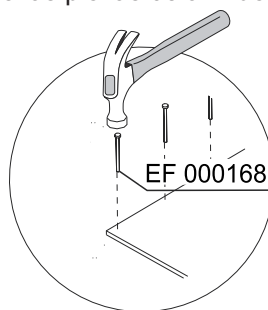

Por favor, note a posição das corredeiras
 Please, note the drawer tracks position
 Por favor, notar la posición de las correderas

PASSO 9 / STEP 9 / PASO 9

Conecte as peças 20, 21 e 22, insira a ferragem EF 000216 e gire para apertar.
 Connect pieces 20, 21 and 22 insert hardware EF 000216 and turn to tighten.
 Junte las piezas 20, 21 y 22, añada el herraje EF 000216 y gire para apretar.

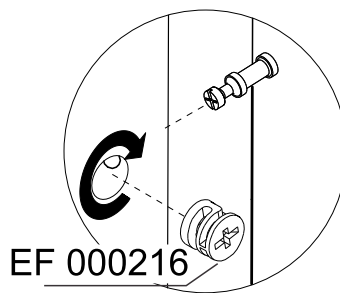
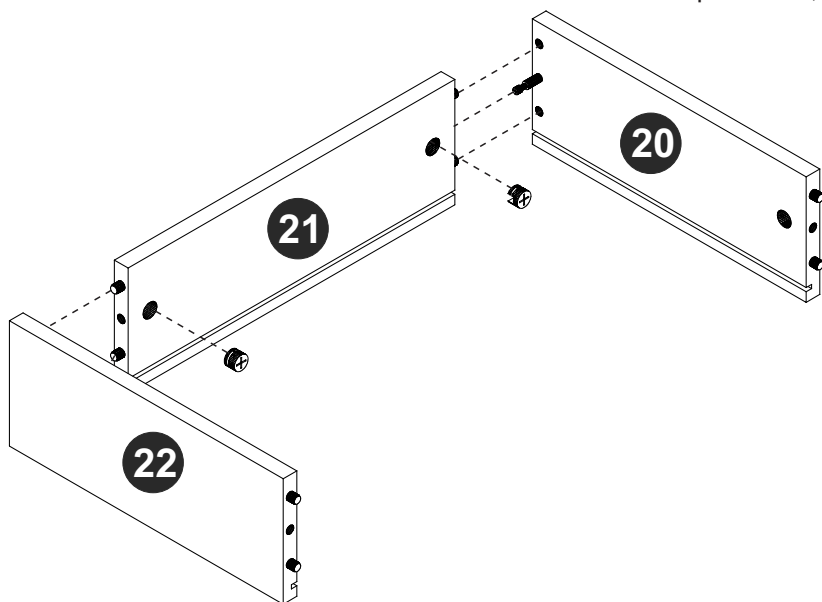

PASSO 10 / STEP 10 / PASO 10

Encaixe a peça 07 entre os espaços específicos.
 Fit piece 07 through the specific space.
 Junte la pieza 07 entre los espacios específicos.

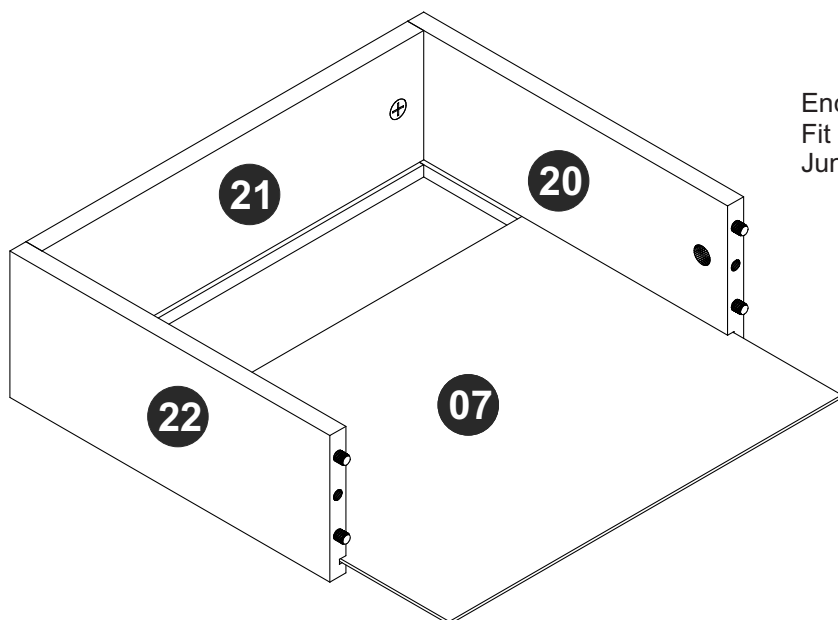

PASSO 11 / STEP 11/ PASO 11

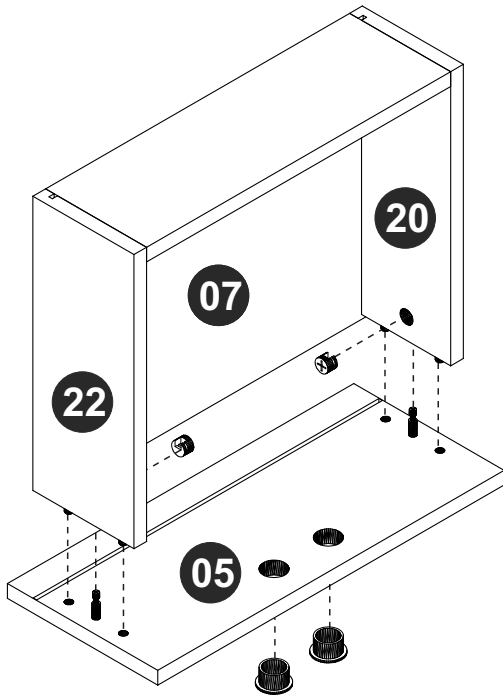

Encaixe a peça 05, insira a ferragem EF 000216 e gire para apertar.
Insira o puxador.
Fix piece 05, insert hardware EF 000216 and turn to tighten.
Insert the handle.
Fije la pieza 05, añada el herraje EF 000216 y gire para apretar.
Añade la manija.

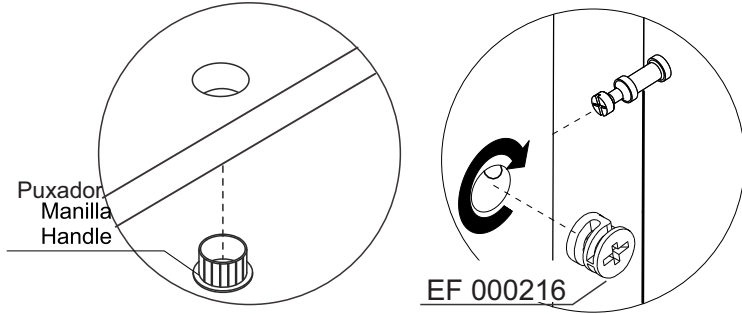

PASSO 12 / STEP 12 / PASO 12

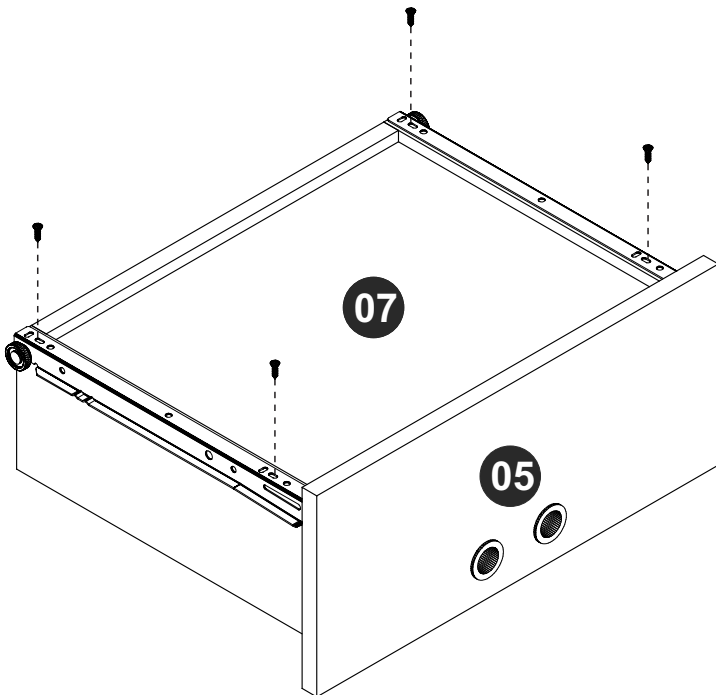

Fixe as corrediças utilizando a ferragem EF 000106.
Attach the drawer tracks using hardware EF 000106.
Fije las correderas utilizando el herraje EF 000106.

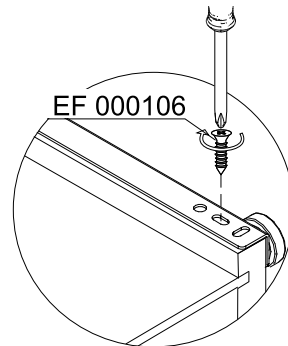

PASSO 13 / STEP 13 / PASO 13

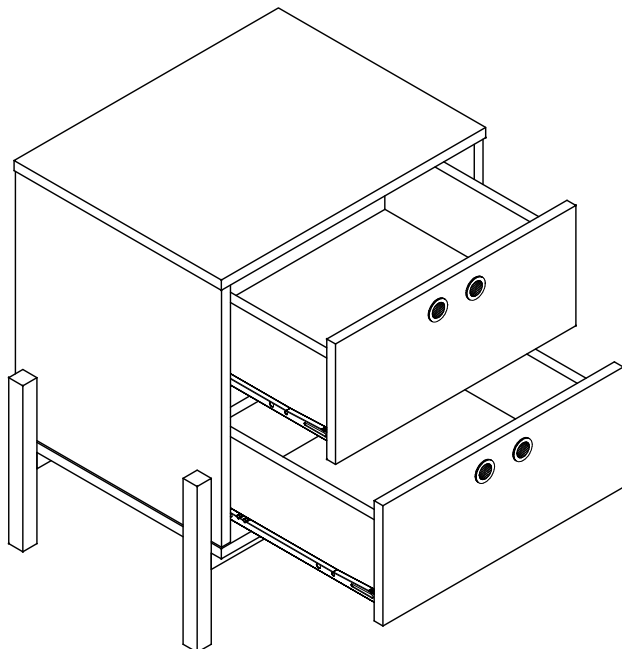

Use os tapa furos para cobrir os parafusos aparentes.
Use o giz para dar o acabamento final ao produto.
Use stickers to cover apparent screws.
Use the chalk to give the final finish on the product.
Utilice los tapa huecos para cubrir los tornillos aparentes.
Utilice la tiza para dar el acabado final al producto.

