



**MANUAL DE MONTAGEM
ASSEMBLY INSTRUCTIONS
INSTRUCCIONES DE MONTAJE**

COD BR: BMU 35

Sumário Summary Resumen

Introdução Introduction Introducción	3
Antes de começar Before starting Antes de comenzar	4
Evite acidentes Avoid accidents Evitar accidentes	4
Dimensões e ferramentas Dimensions and tools Dimensiones y herramientas	5
Identificação das peças Identifying parts Identificación de las piezas	6
Acessórios incluídos na caixa Hardware included in box Accesorios incluidos en la caja	7
Montagem do móvel Furniture assembly Montaje del mueble	8

Introdução Introduction Introducción

Leia atentamente este manual e siga os passos indicados para que o produto não perca a garantia e também para uma perfeita montagem.

Read this manual and follow the steps in order to keep the guarantee and also for the perfect fit.

Lea este manual y siga los pasos para que el producto no pierda la garantía y también para el ajuste perfecto.

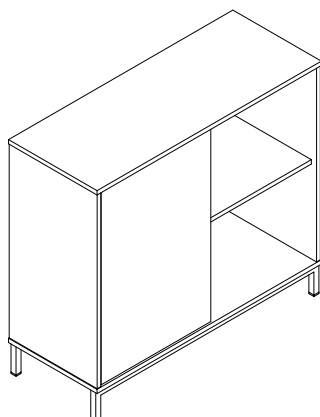

Antes de começar Before starting Antes de comenzar

Antes de começar a montagem prepare o ambiente, deixando-o completamente limpo e com bom espaço para iniciar o trabalho.

Prepare the room before starting the assembly, leaving it completely clean and the area in good condition to start the work.

Antes de comenzar el montaje prepare el ambiente, dejándolo completamente limpio y con espacio para empezar el trabajo.

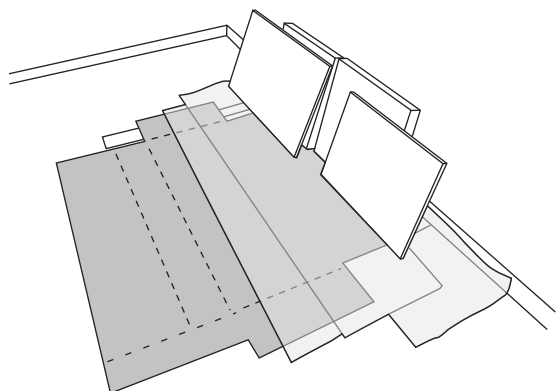

Utilize o papelão da própria embalagem para separar e apoiar as peças retiradas das caixas.

Use the cardboard of the packaging to separate and support the parts removed from the boxes.

Utilice el cartón del embalaje para separar y apoyar las piezas.

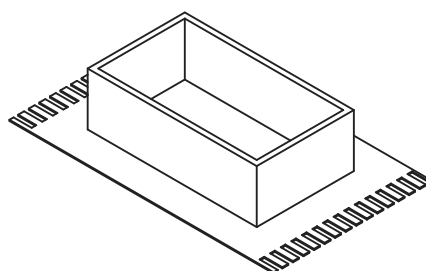

Forre a área de montagem com um cobertor ou tapete. Assim, você evita avarias nas peças durante o processo de montagem.

Cover the assembly area with a blanket or carpet to avoid damaging the parts during the assembly process.

Cubrir la zona de ensamble con una manta o alfombra. De este modo, se evitan daños en las piezas durante el proceso de montaje.



Evite acidentes Avoid accidents Prevenir accidentes

Solicitamos observar atentamente as orientações de montagem como: fixação do produto na parede, colocação de cola em locais específicos necessários, o peso suportado pelo produto, etc...

You are requested to carefully observe the assembly instructions regarding: fixing of products to the wall, adding glue where indicated, product weight limit, etc.

Pedimos que lea atentamente las instrucciones, principalmente las informaciones de fijación del producto en la pared, colocación de pegamento en local específico y necesario, el peso soportado por el producto etc...

Não escale ou se apoie no móvel.

Do not climb or lean on the furniture.

No se suba ni se apoye en el mueble.

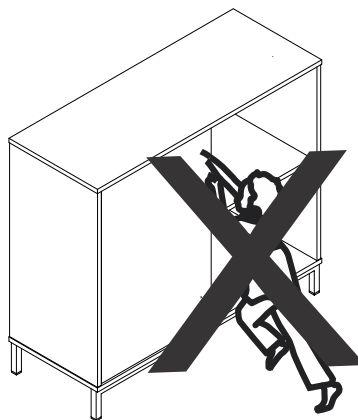

Dimensões e ferramentas
Dimensions and tools
Dimensiones y herramientas

Dimensões:

L: 900 A: 810 P: 355 mm

Dimensions:

W: 35.43 H: 31.88 D: 13.97 inches

Dimensiones:

L: 900 A: 810 P: 355 mm

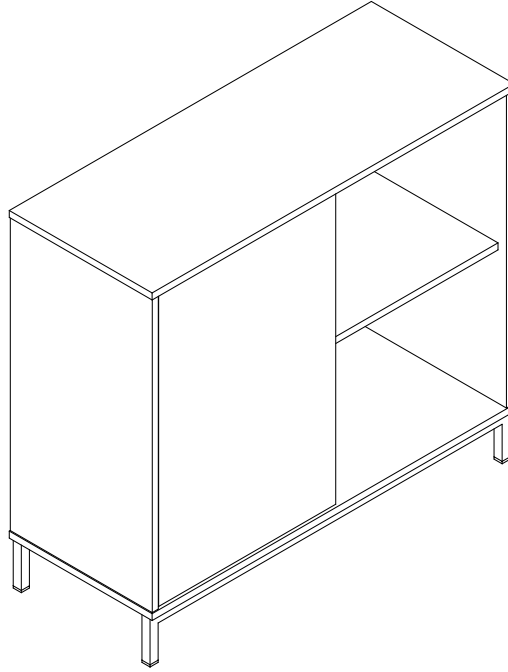

Limpeza
Cleaning
Limpieza

Pano levemente umedecido com água, seguido de pano seco, não utilizar produtos químicos ou abrasivos.
You can clean the product with slightly dampened cloth followed by a dry cloth. Do not use chemicals or abrasives.
Solamente utilizar un paño húmedo y después un paño seco, no utilice productos químicos o abrasivos.

Todas as peças do móvel foram marcadas com um número. Antes de começar a montagem, identifique as peças numeradas em relação às instruções de montagem. Uma vez concluída a montagem, os números podem ser facilmente removidos com um pano ligeiramente embebido em álcool. Use álcool apenas para remover números das peças.

All the furniture parts have been marked with a number. Before you start assembling, please identify the numbered parts in relation to the assembly instructions. Once assembly is completed, the numbers can be easily removed with a cloth slightly damped in alcohol. Use alcohol only to remove part numbers.

Todos las piezas del mueble fueron marcadas con un número. Antes de empezar el montaje, identifique las piezas numeradas en relación con las instrucciones de montaje. Una vez que se completa el armado, los números se pueden quitar fácilmente con un paño ligeramente empapado en alcohol. Use alcohol solo para eliminar los números de las piezas.

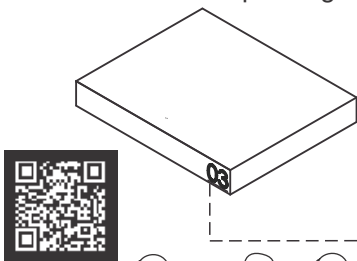

UTILIZE ALCOOL APENAS PARA REMOVER O NUMERO DAS PEÇAS
USE ALCOHOL ONLY TO REMOVE PART NUMBERS
UTILICE ALCOHOL SOLAMENTE PARA ELIMINAR EL NUMERO DE LAS PIEZAS

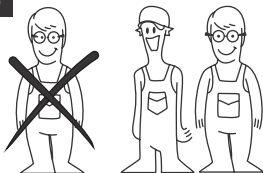

Para facilitar a montagem, utilize uma parafusadeira elétrica.
To speed assembly, use an electronic screwdriver.
Para facilitar el armado, utilice un destornillador eléctrico.

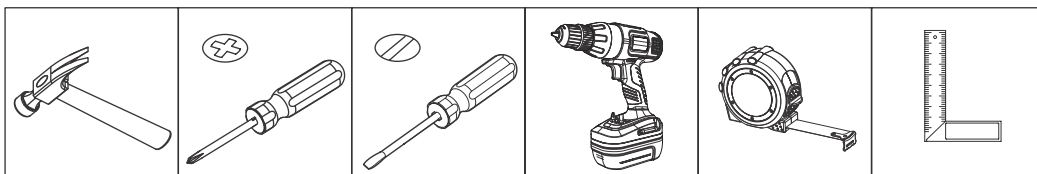

COD BR: BMU 35

PEÇA	DESCRIÇÃO	QUANT.	PART DESCRIPTION	QTY	PIEZA	DESCRIPCIÓN	CANTIDAD	
001	BASE	1	001	BASE	1	001	BASE	1
002	TAMPO	1	002	TOP	1	002	TAPA	1
003	LATERAL ESQUERDA	1	003	LEFTSIDE	1	003	LATERAL IZQUIERDA	1
004	LATERAL DIREITA	1	004	RIGHT SIDE	1	004	LATERAL DERECHA	1
005	DIVISÓRIA	1	005	PARTITION	1	005	PARTICIÓN	1
006	PRATELEIRA	1	006	SHELF	1	006	REPISA	1
007	PORTA	1	007	DOOR	1	007	PUERTA	1
008	COSTA MAIOR	1	008	LONGER BACK	1	008	REVÉS MAYOR	1
009	COSTA MENOR	2	009	LOWER BACK	2	009	REVÉS MENOR	2
010	PÉS	2	010	FEET	2	010	PIES	2

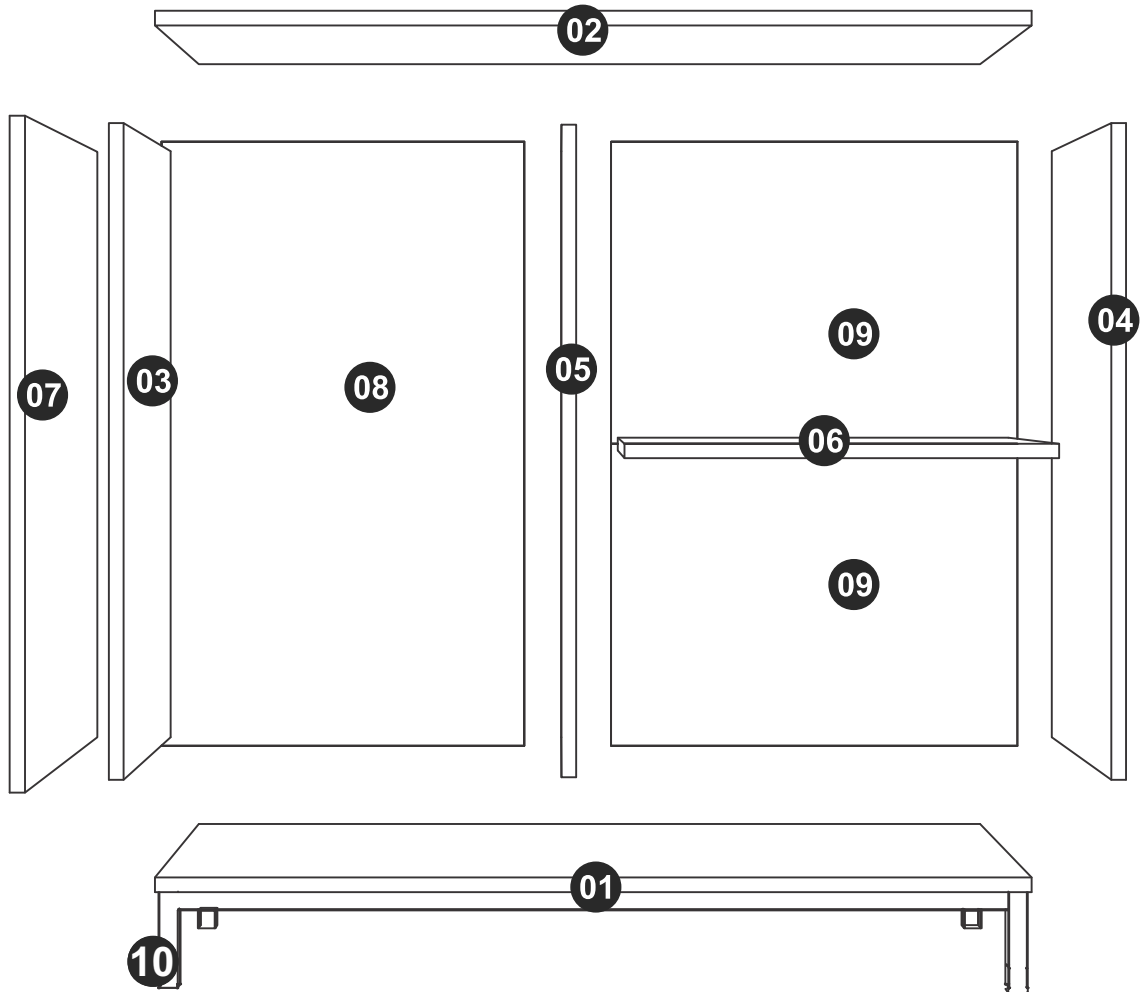

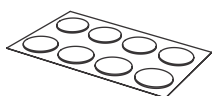

TAPA FUROS x 10
STICKER x 10
TAPA HUECOS x 10



EF 000132 x 6
4x50 CC



EF 000216 X 10



EF 000033x 16
8x30

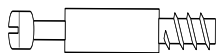

EF 000094 X 10



EF 000129 x 4
4 X 35 CC

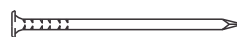

EF 000168 X 50
10x10 C/C



GIZ x 01
CHALK x 01
TIZA x 01

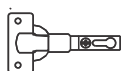

EF 000043 X 2



EF 000025 X 2



EF 000106 x 8
3,5x14 CC

Utilize para medir as ferragens.

Utilice para medir el herraje.

Use for measuring the hardware.

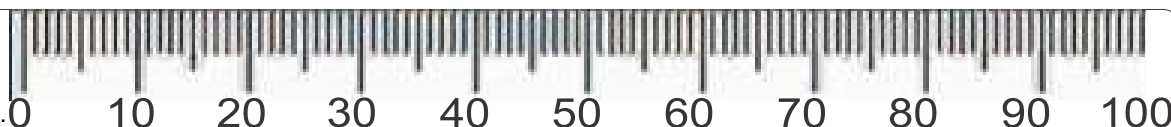

Garantia (exclusivo para o Brasil/exclusivo de Brasil/exclusive to Brazil):

A garantia dos produtos fabricados pela BRV Móveis, abrange eventuais defeitos-vícios de fabricação, no prazo estabelecido pelo código de Defesa do Consumidor, em seu artigo 26.II. o qual prevê a garantia de 90 (noventa) dias.

A = 11 KG - 24.25 LB

B = 5 KG - 11.02 LB

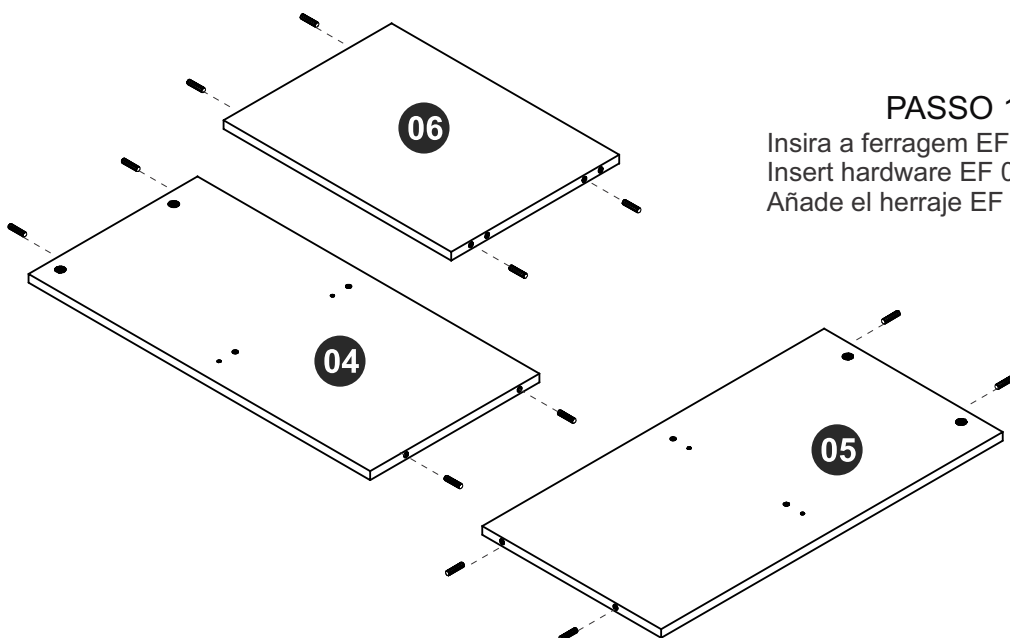
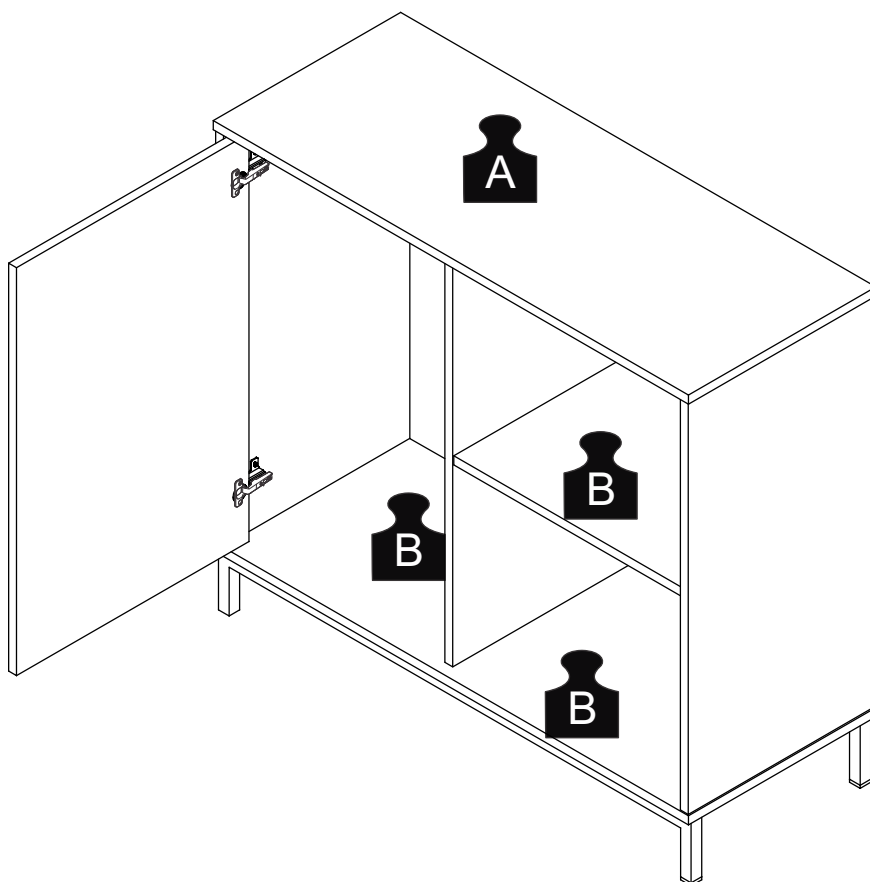

PASSO 1 / STEP 1 / PASO 1

Insira a ferragem EF 000033 nas peças 04, 05 e 06.
Insert hardware EF 000033 into pieces 04, 05 and 06.
Añade el herraje EF 000033 en las piezas 04, 05 y 06.

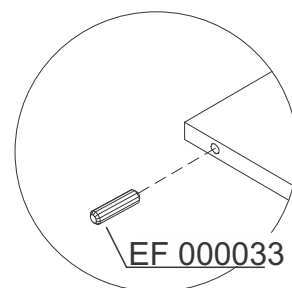

PASSO 2 / STEP 2 / PASO 2

Fixe a ferragem EF 000094 nas peças 02, 04 e 05.
Attach hardware EF 000094 into pieces 02, 04 and 05.
Añade el herraje EF 000094 en las piezas 02, 04 y 05.

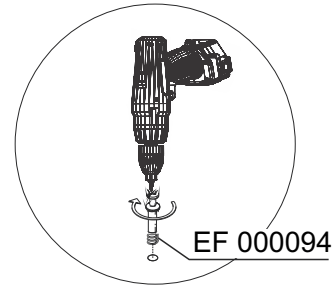
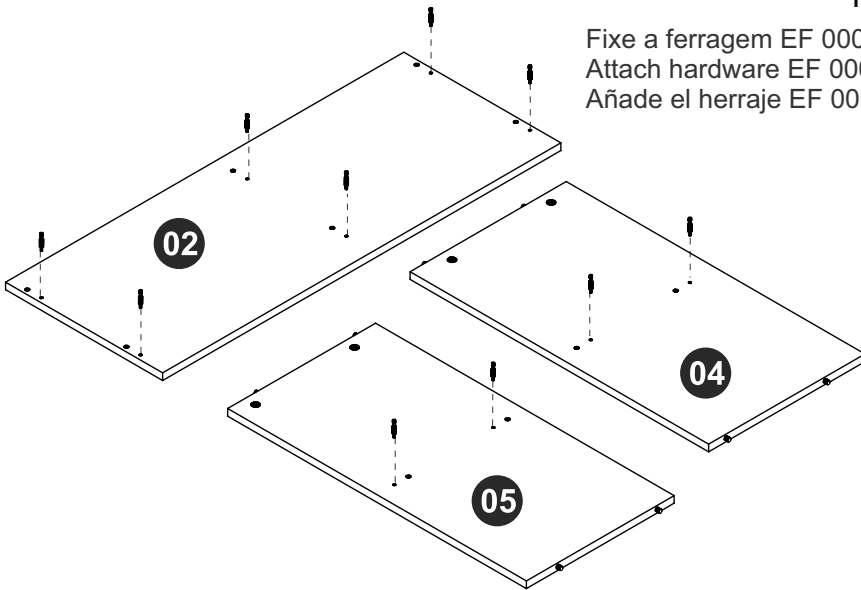

PASSO 3 / STEP 3 / PASO 3

Fixe a ferragem EF 000025 na peça 03 usando a ferragem EF 000106. Insira a ferragem EF 000033.
Fix hardware EF 000025 into piece 03 using hardware EF 000106. Insert hardware EF 000033.
Fije el herraje EF 000025 en la pieza 03 utilizando el herraje EF 000106. Añade el herraje EF 000033.

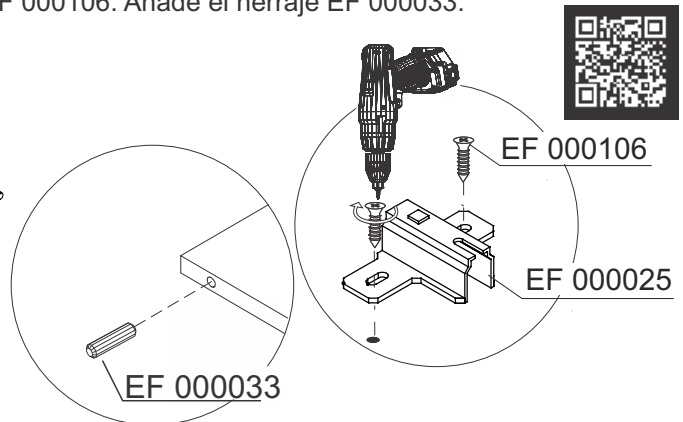
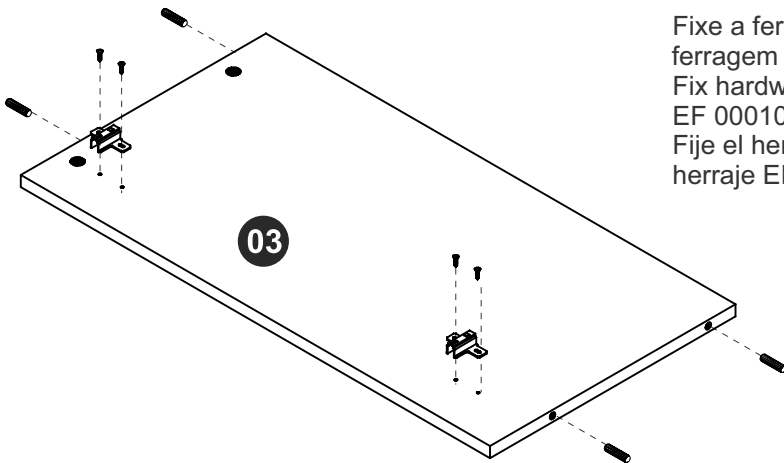

PASSO 4 / STEP 4 / PASO 4

Fixe a ferragem EF 000043 na peça 07 utilizando a ferragem EF 000106.
Fix hardware EF 000043 to piece 07 using hardware EF 000106.
Fije el herraje EF 000043 a la pieza 07 utilizando el herraje EF 000106.

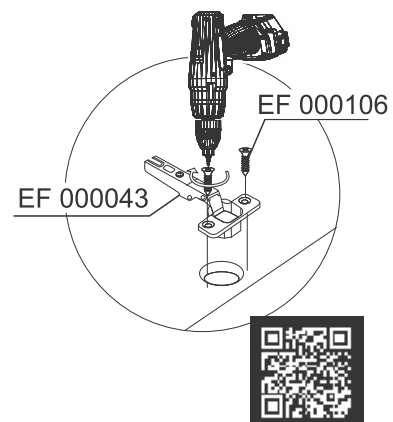
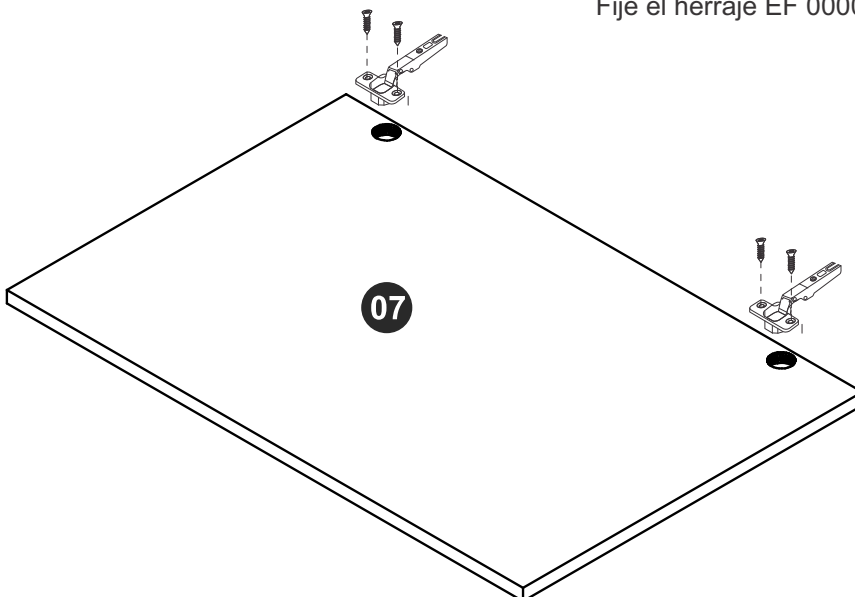

PASSO 5 / STEP 5 / PASO 5

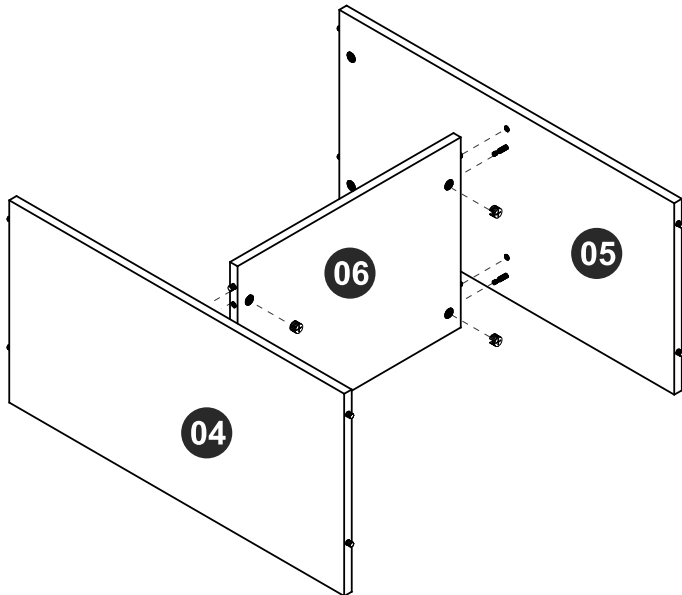

Conecte as peças 04, 05 e 06, insira a ferragem EF 000216 e gire para apertar.
Connect pieces 04, 05 and 06, insert hardware EF 000216 and turn to tighten.
Junte las piezas 04, 05 y 06, añáde el herraje EF 000216 y gire para apretar.

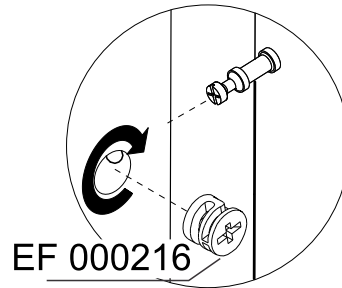

PASSO 6 / STEP 6 / PASO 6

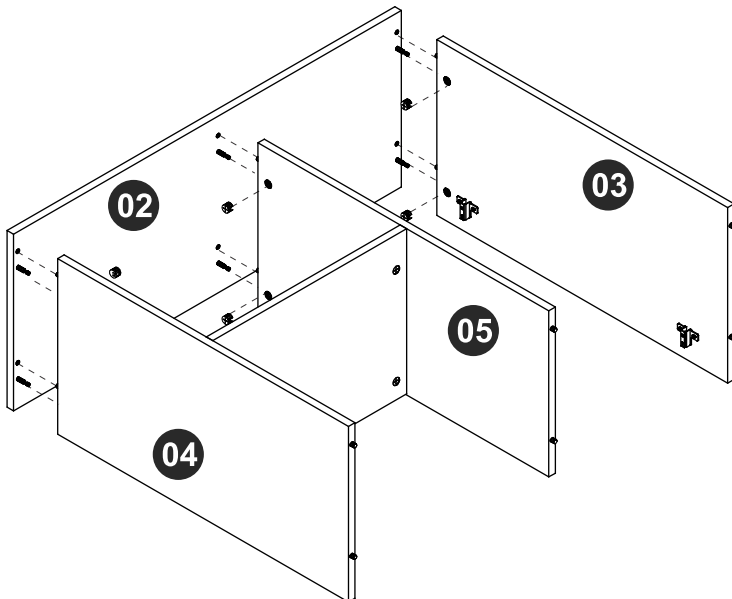

Conecte as peças 03 e 02, insira a ferragem EF 000216 e gire para apertar.
Connect pieces 03 and 02, insert hardware EF 000216 and turn to tighten.
Junte las piezas 03 y 02, añáde el herraje EF 000216 y gire para apretar.

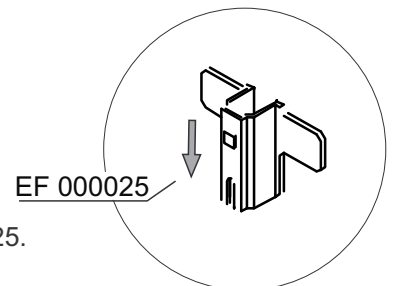
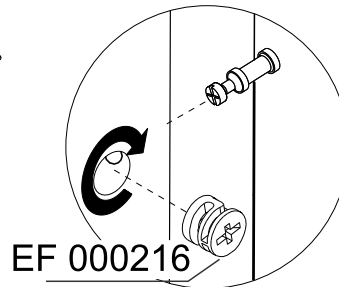

Por favor, observe a posição da ferragem EF 000025.
Please, note hardware EF 000025 position.
Por favor, notar la posición del herraje EF000025.

PASSO 7 / STEP 7 / PASO 7

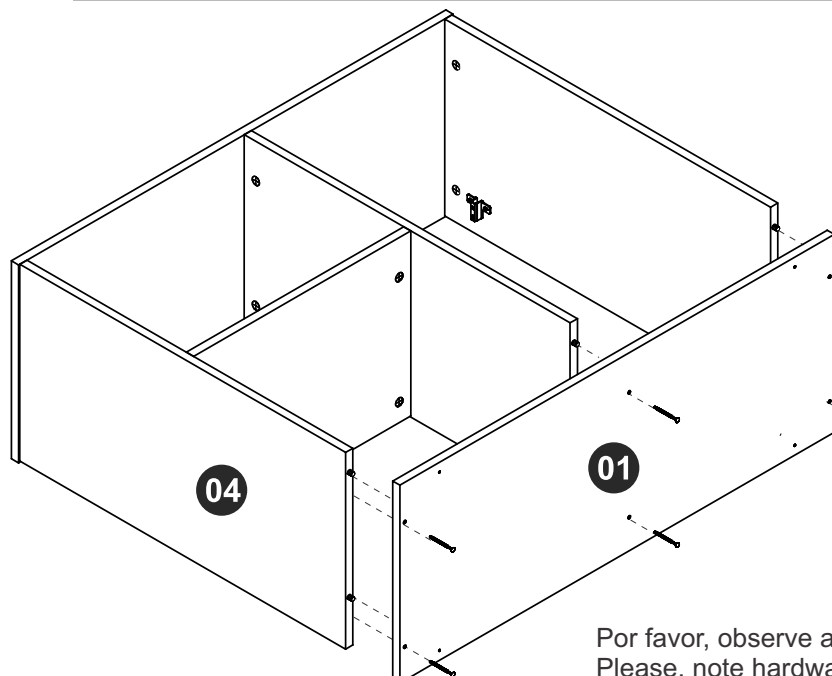

Fixe a peça 01 à parte montada no passo anterior utilizando a ferragem EF 000132.
Fix piece 01 to the part assembled in the previous step using hardware EF 000132.
Fije la pieza 01 a la parte armada en el paso anterior utilizando el herraje EF 000132.

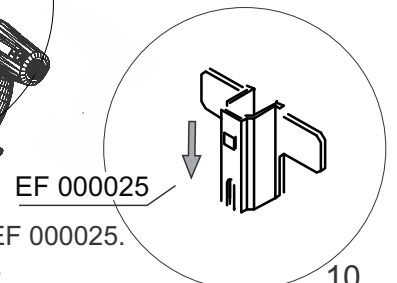
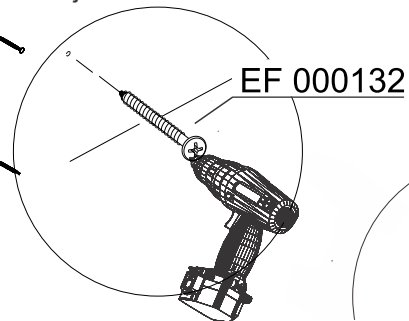

Por favor, observe a posição da ferragem EF 000025.
Please, note hardware EF 000025 position.
Por favor, notar la posición del herraje EF000025.

PASSO 8 / STEP 8 / PASO 8

Fixe os pés à parte montada no passo anterior utilizando a ferragem EF 000129.
Attach the feet to the part assembled in the previous step using hardware EF 000129.
Fije los pies a la parte armada en el paso anterior utilizando el herraje EF 000129.

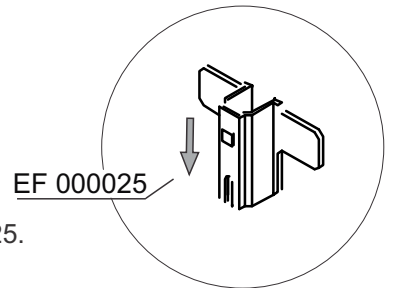
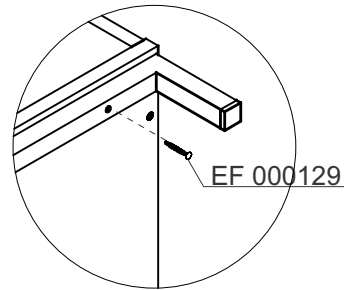
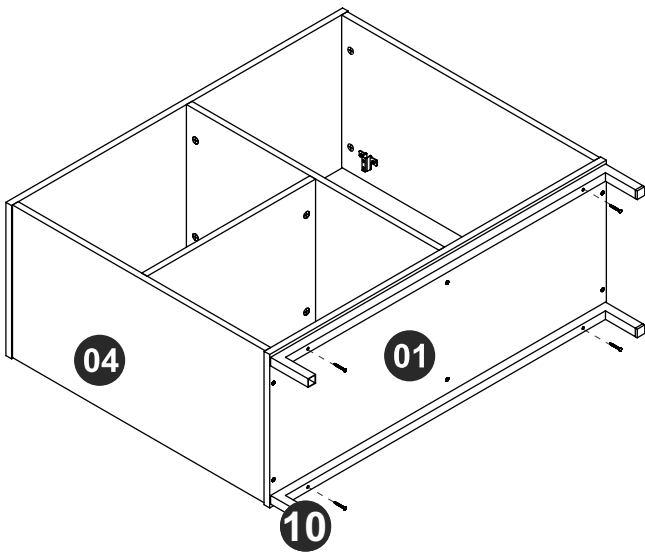

Por favor, observe a posição da ferragem EF 000025.
Please, note hardware EF 000025 position.
Por favor, notar la posición del herraje EF000025.

PASSO 9 / STEP 9 / PASO 9

Fixe as peças 08 e 09 ao móvel utilizando a ferragem EF 000168.
Fix pieces 08 and 09 at the furniture using hardware EF 000168.
Fije las piezas 08 y 09 al mueble utilizando el herraje EF 000168.

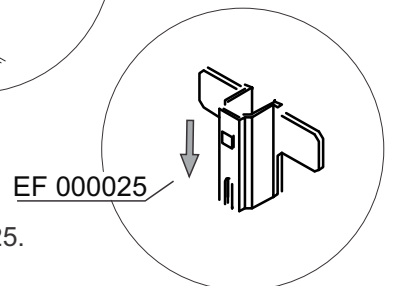
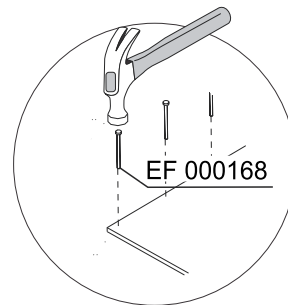
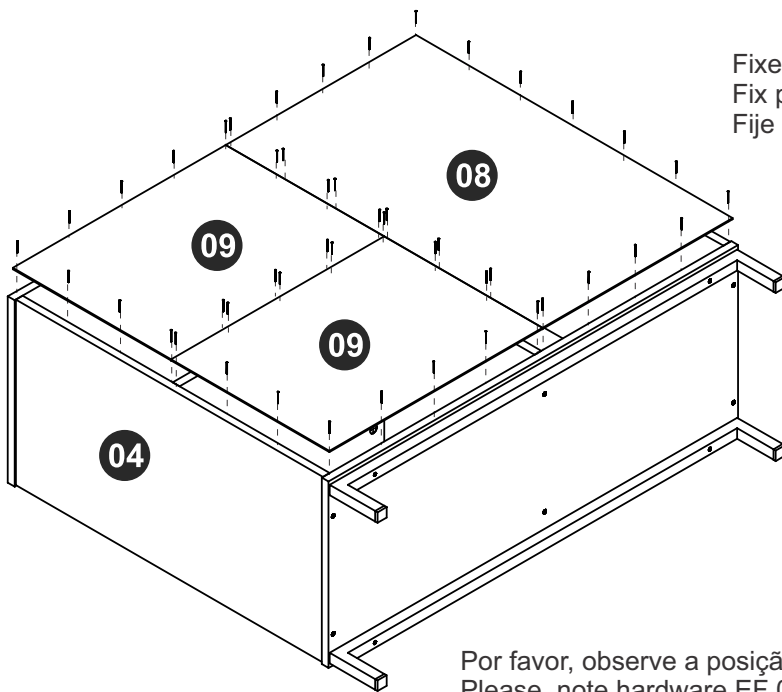

Por favor, observe a posição da ferragem EF 000025.
Please, note hardware EF 000025 position.
Por favor, notar la posición del herraje EF000025.

PASSO 10 / STEP 10 / PASO 10

Fixe a peça 07 ao móvel montado.
Fix piece 07 at the assembled furniture.
Fije la pieza 07 al mueble armado.

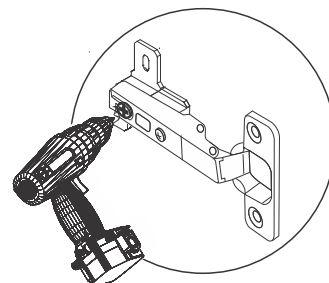
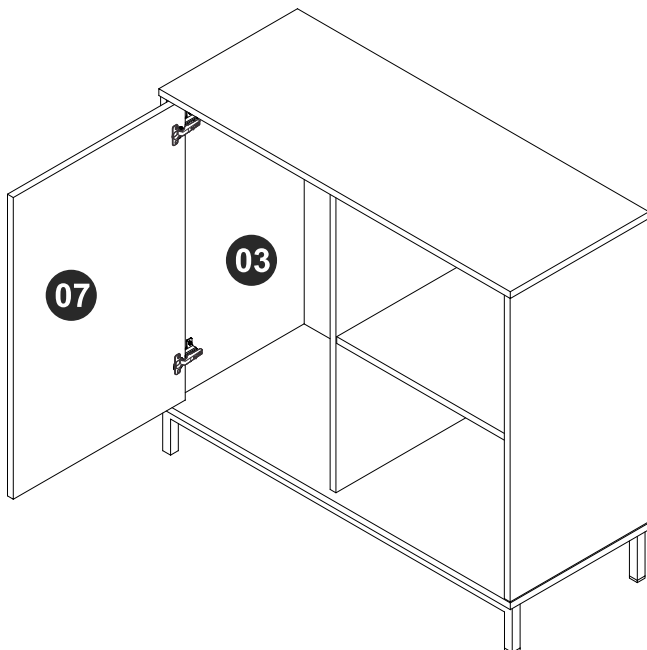

PASSO 11 / STEP 11 / PASO 11

Use os tapa furos para cobrir os parafusos aparentes.
Use stickers to cover apparent screws.
Utilice los tapa huecos para cubrir los tornillos aparentes.

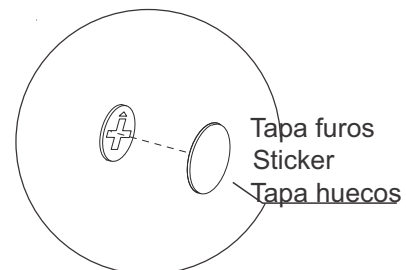
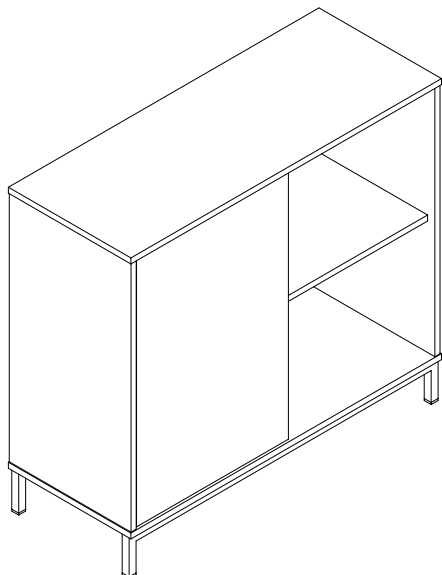

PASSO 12 / STEP 12 / PASO 12

Use o giz para dar o acabamento final ao produto.
Use the chalk to give the final finish on the product.
Utilice la tiza para dar el acabado final al producto.

