

# POZZA



PE 09



Rua Fioravante Pozza, 404-i - Bento gonçaves, RS - Brasil

### Atenção!

- Parabéns, você está adquirindo um produto com a qualidade Pozza.
- **IMPORTANTE!** Para que o produto não perca a garantia, solicitamos observar atentamente as orientações de montagem.
- Aconselhamos utilizar a embalagem para forrar o chão, afim de não danificar o produto.

### Attention!

- Congratulations, you are acquiring a product with Pozza quality.
- **IMPORTANT!** In order to keep the guarantee of the product, we request to carefully observe the assembly instructions.
- We advise to use the package to protect the floor in order to prevent damages.

### Atención!

- Felicitaciones, usted está adquiriendo un producto con la calidad Pozza.
- **IMPORTANTE!** Para que el producto no pierda la garantía, pedimos que lea atentamente las instrucciones.
- Si recomienda utilizar la caja de cartón para cubrir el piso de tal manera que no se dañe el producto.

### Limpeza

- Para manutenção e melhor conservação do produto cromado, não se deve deixar a superfície exposta à umidade e ao acúmulo de pó.
- Não utilizar panos úmidos, produtos químicos e materiais ásperos na limpeza. A cada 30 dias limpar o produto com flanela e aplicar cera de polir.

### Cleaning

- For maintenance and better preservation of the chrome product, the surface must not be exposed to humidity and to the accumulation of dust.
- Do not use damp cloths, chemicals and rough materials for cleaning. Every 30 days, clean the product with flannel and apply polishing wax.

### Limpieza

- Para el mantenimiento y mejor conservación del producto cromo no se debe dejar la superficie expuesta a la humedad ya la acumulación de polvo.
- No utilizar paño húmedo, productos químicos y materias ásperas en la limpieza. Cada 30 días limpiar el producto con flanela y aplicar cera de pulir.

### Ferragens Hardwares Herrajes



EF 000033 x 4  
8x30



EF 000094 X 4



EF 000216 X 4

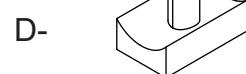

Ponteiras x 4  
Plastic tips x 4  
Puntas x 4



EF 000819 x 12  
4,5X16 CF PRETO

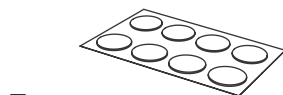

TAPA FUROS x 4  
STICKER x 4  
TAPAS PLÁSTICAS x 4



GIZ x 01  
CHALK x 01  
TIZA x 01

## Peças / Pieces / Piezas

PEÇA	DESCRIÇÃO	QUANT.	PART	DESCRIPTION	QTY	PIEZA	DESCRIPCION	CANTIDAD
001	BASE	1	001	BASE	1	001	BASE	1
002	TAMPO	1	002	TOP	1	002	TAPA	1
003	PRATELEIRA	1	003	SHELF	1	003	REPISA	1
007	COSTA	1	007	BACK	1	007	REVÉS	1
008	ESTRUTURA METÁLICA	2	008	METAL STRUCTURE	2	008	ESTRUCTURA METÁLICA	2

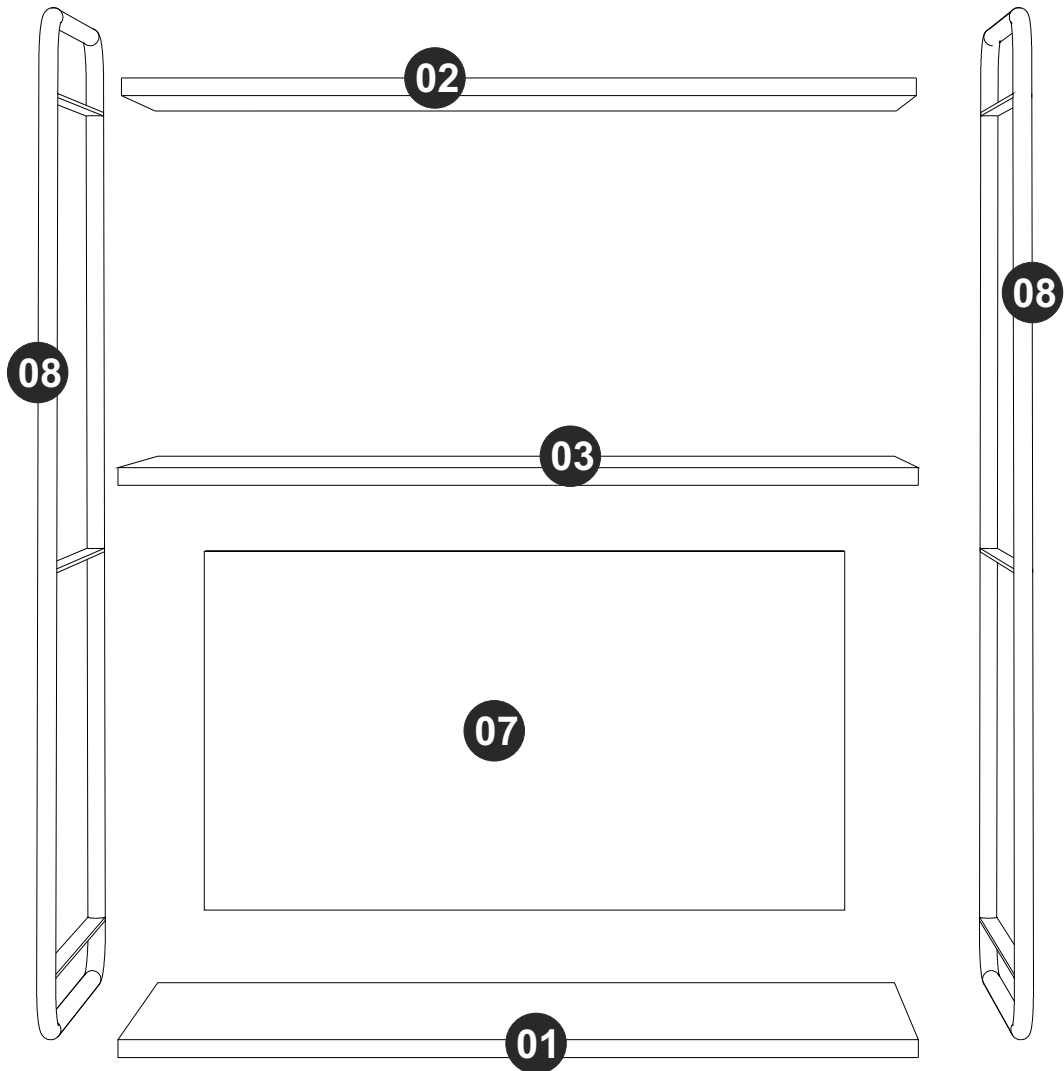

**A** = 10 KG - 22.04 LB

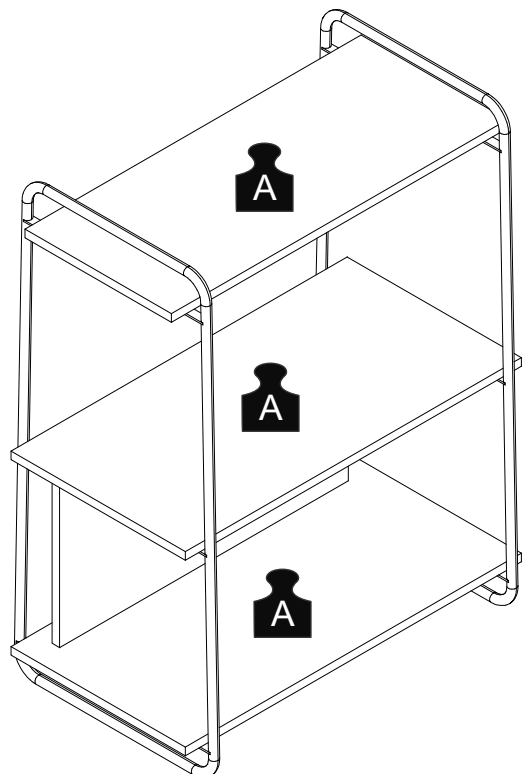

**PASSO 1 / STEP 1 / PASO 1**

Fixe a ferragem B nas peças 01 e 03.  
Attach hardware B into pieces 01 and 03.  
Fije el herraje B en las piezas 01 y 03.

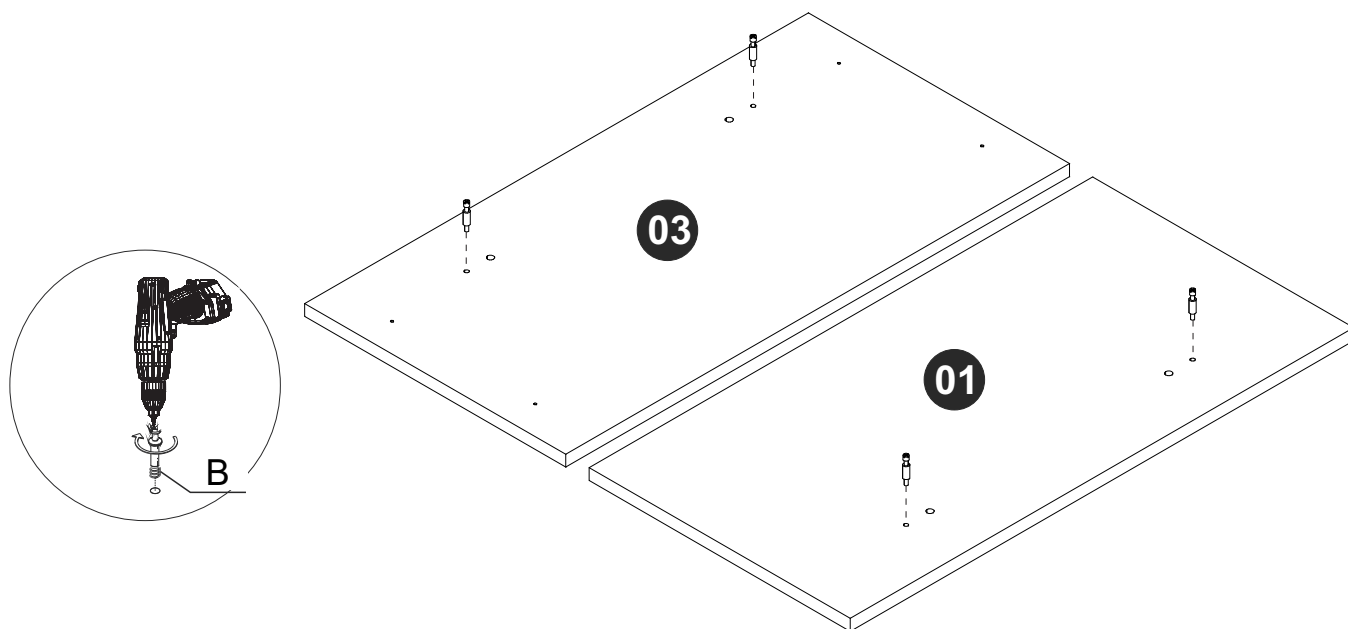

**PASSO 2 / STEP 2 / PASO 2**

Insira a ferragem A na peça 07.  
Insert hardware A into piece 07.  
Añade el herraje A en la pieza 07.

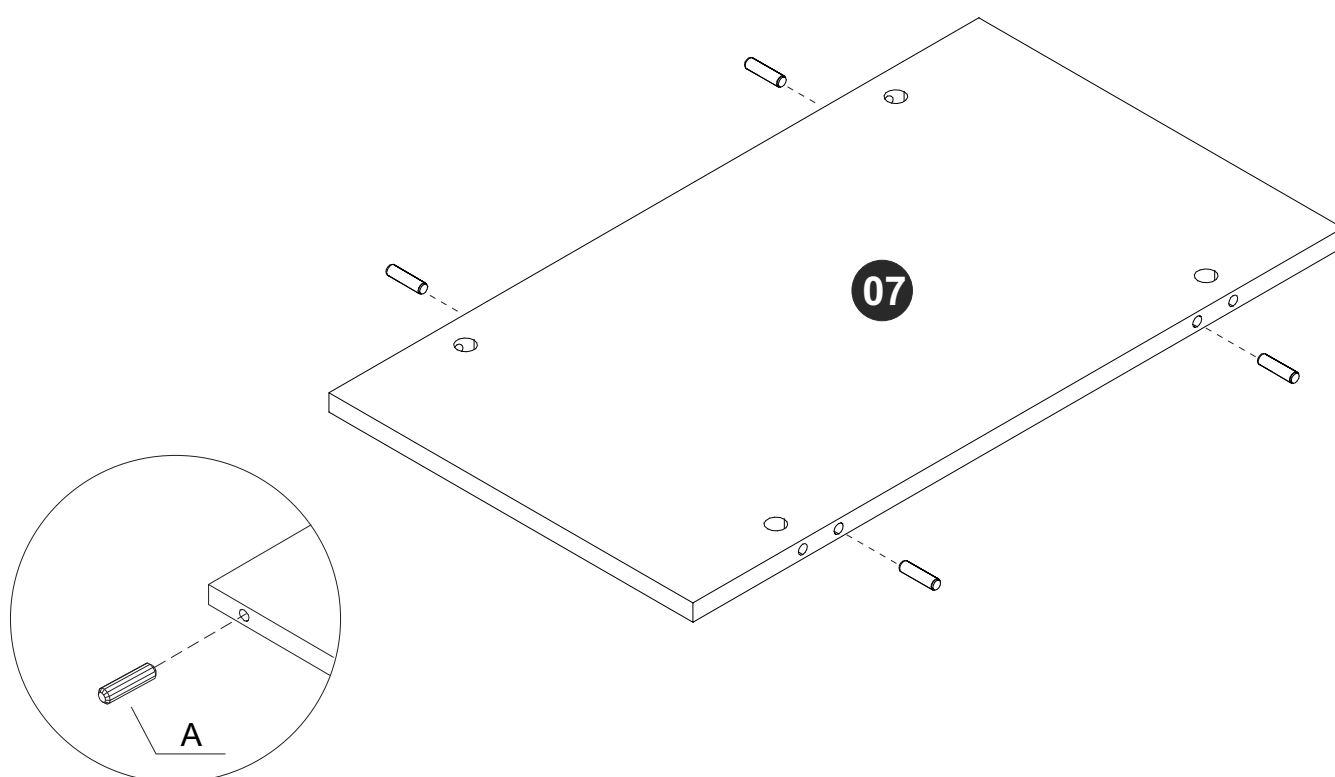

### PASSO 3 / STEP 3 / PASO 3

Conecte as peças 01, 03 e 07, insira a ferragem C e gire para apertar.  
Connect pieces 01, 03 and 07, insert hardware C and turn to tighten.  
Junte las piezas 01, 03 y 07, añada el herraje C y gire para apretar.

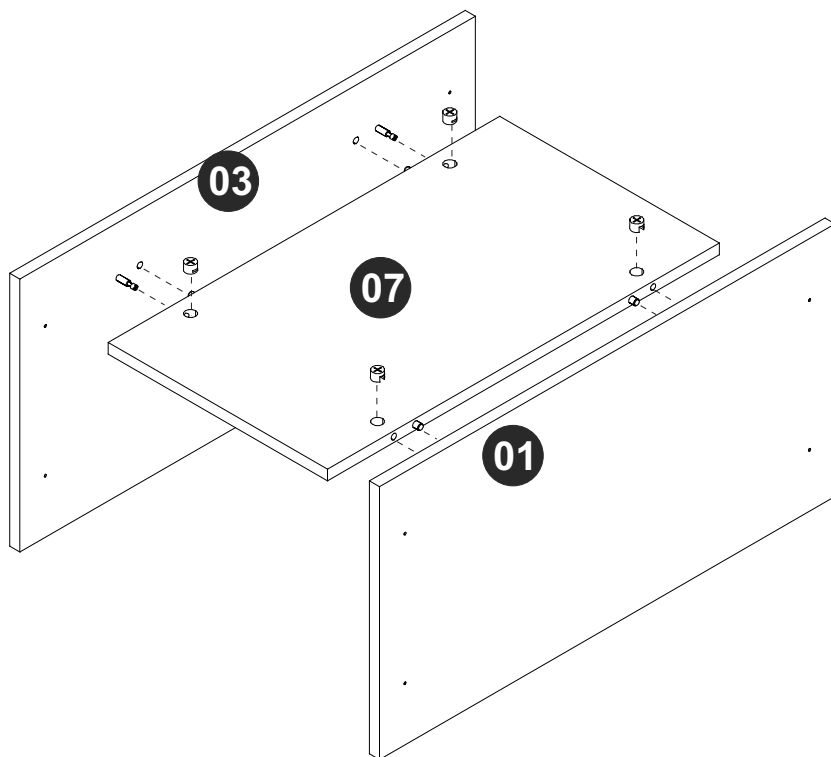
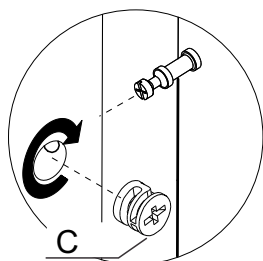

### PASSO 4 / STEP 4 / PASO 4

Conecte a peça 08 à parte montada no passo anterior utilizando a ferragem E.  
Connect piece 08 to the part assembled into the previous step using hardware E.  
Junte la pieza 08 a la parte armada en el paso anterior utilizando el herraje E.

Por favor, observe a posição do furo.  
Please, note the hole position.  
Por favor, observe la posición del agujero.

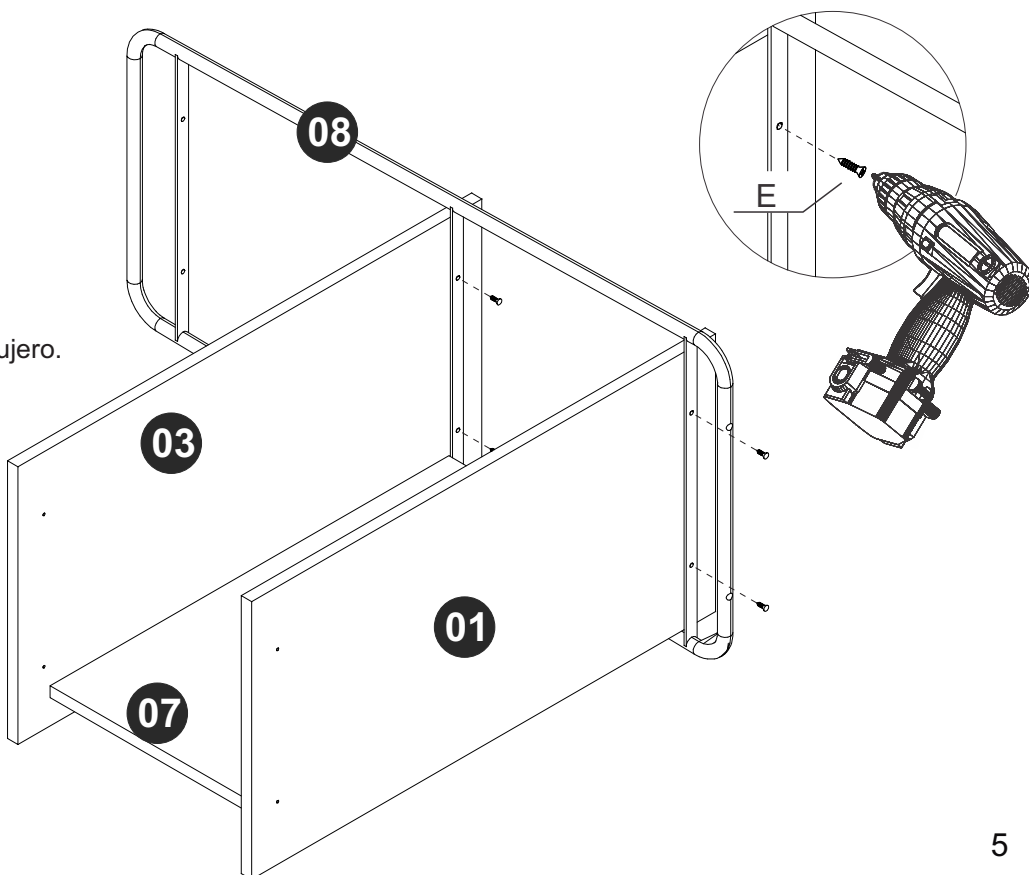
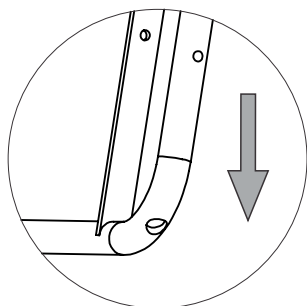

### PASSO 5 / STEP 5 / PASO 5

Conecte a peça 08 à parte montada no passo anterior utilizando a ferragem E.  
Connect piece 08 to the part assembled into the previous step using hardware E.  
Junte la pieza 08 a la parte armada en el paso anterior utilizando el herraje E.

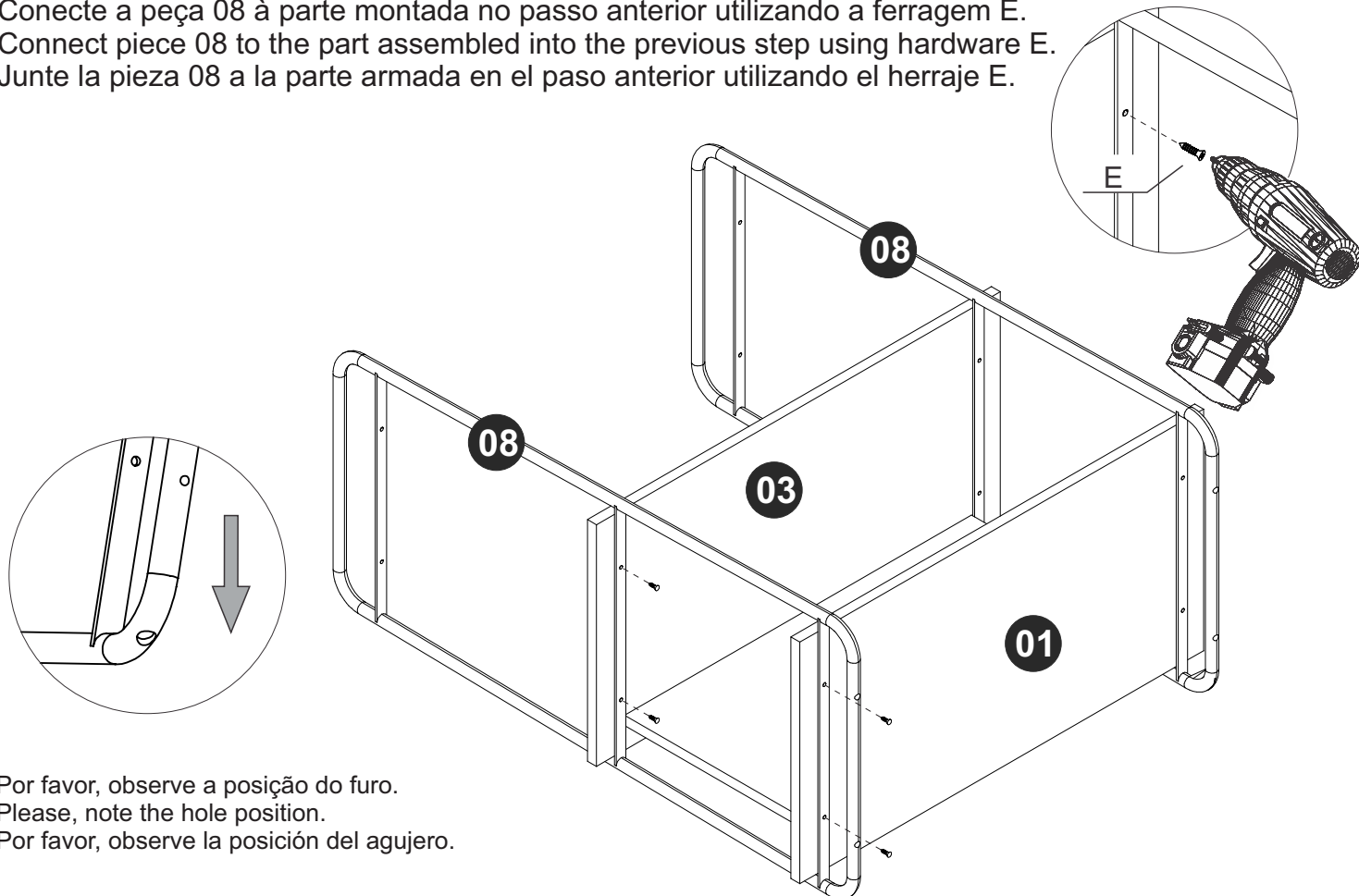

Por favor, observe a posição do furo.  
Please, note the hole position.  
Por favor, observe la posición del agujero.

### PASSO 6 / STEP 6 / PASO 6

Fixe a peça 02 ao móvel montado utilizando a ferragem E.  
Attach piece 02 at the assembled furniture using hardware E.  
Fije la pieza 02 al mueble armado utilizando el herraje E.

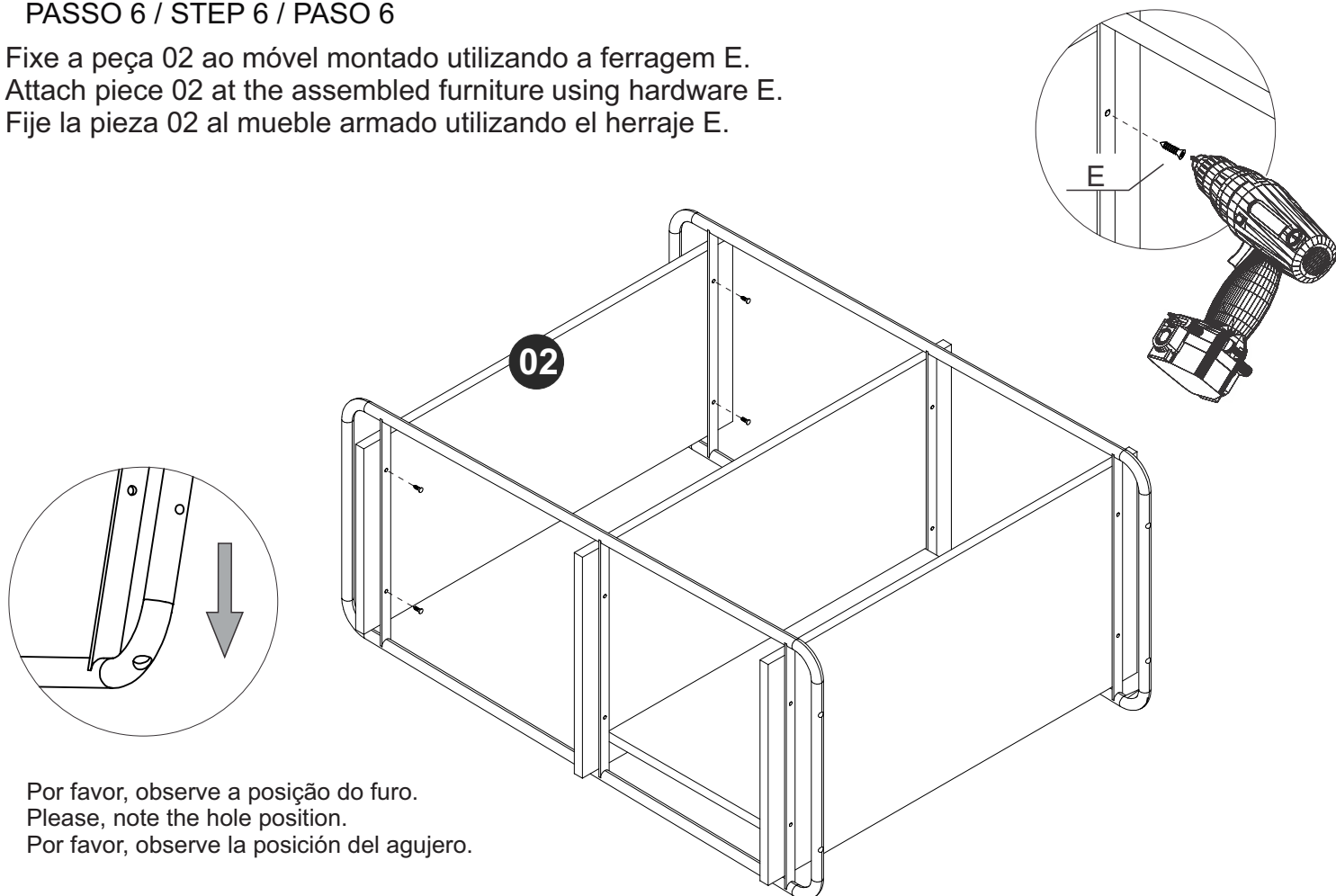

Por favor, observe a posição do furo.  
Please, note the hole position.  
Por favor, observe la posición del agujero.

PASSO 7 / STEP 7 / PASO 7

Encaixe a ferragem D nas peças 08.  
Fit hardware D into pieces 08.  
Junte el herraje D en las piezas 08.

Por favor, observe a posição do furo.  
Please, note the hole position.  
Por favor, observe la posición del agujero.

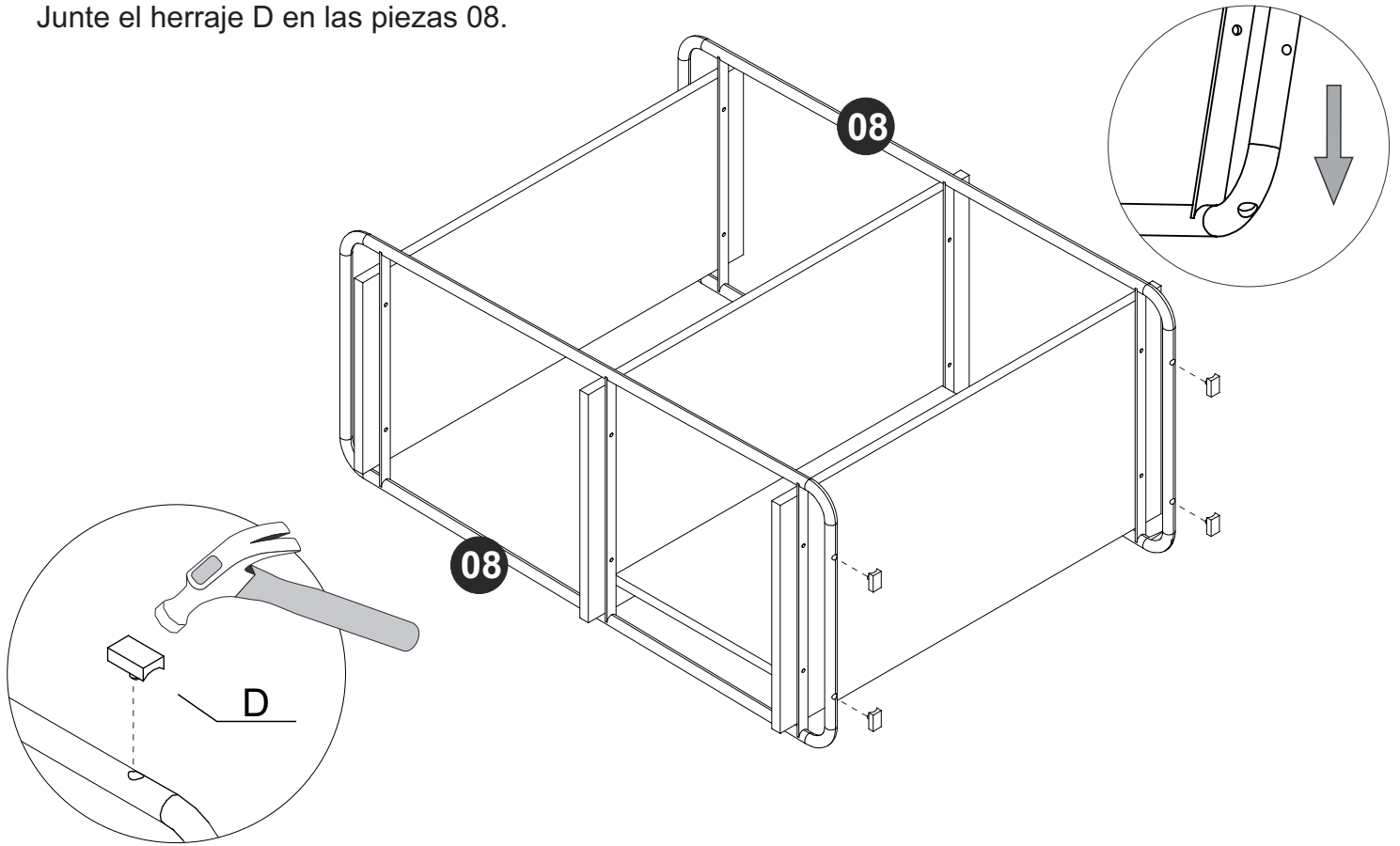

PASSO 8 / STEP 8 / PASO 8

Utilize os tapa furos para cobrir os parafusos aparentes.  
Use the sticker to cover the apparent screws.  
Utilice los tapa huecos para cubrir los tornillos aparentes.

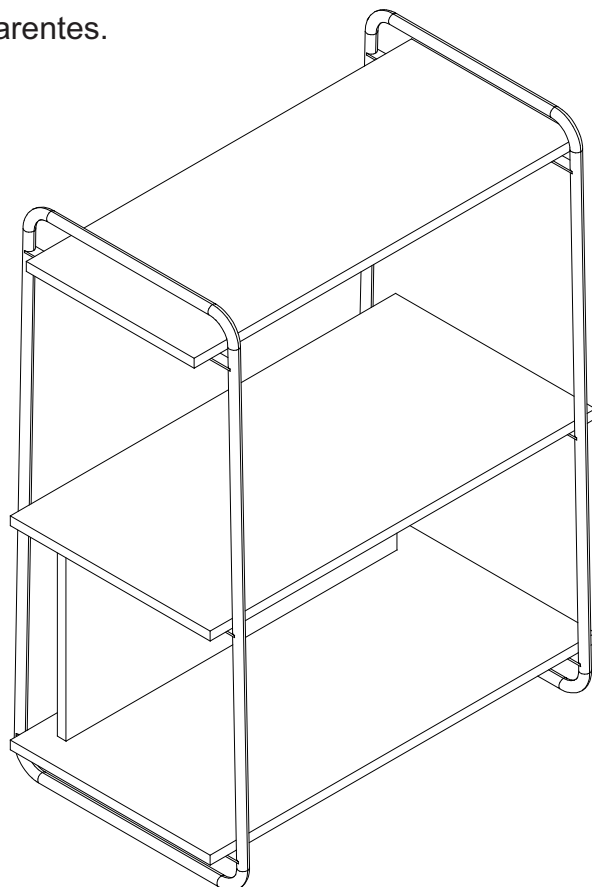
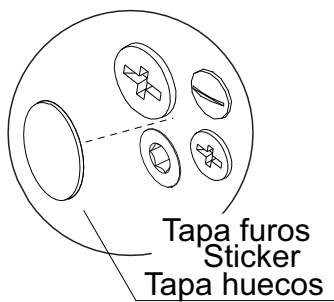

PASSO 9 / STEP 9 / PASO 9

Utilize o giz para dar o acabamento final ao produto.

Use the chalk to give the final finish on the product.

Utilice la tiza para dar el acabado final al producto.

