



MANUAL DE MONTAGEM
ASSEMBLY INSTRUCTIONS
INSTRUCCIONES DE MONTAJE

COD BR: BE 79

Sumário Summary Resumen

Introdução Introduction Introducción	3
Antes de começar Before starting Antes de comenzar	4
Evite acidentes Avoid accidents Evitar accidentes	4
Dimensões e ferramentas Dimensions and tools Dimensiones y herramientas	5
Identificação das peças Identifying parts Identificación de las piezas	6
Acessórios incluídos na caixa Hardware included in box Accesorios incluidos en la caja	7
Montagem do móvel Furniture assembly Montaje del mueble	8

Introdução Introduction Introducción

Leia atentamente este manual e siga os passos indicados para que o produto não perca a garantia e também para uma perfeita montagem.

Read this manual and follow the steps in order to keep the guarantee and also for the perfect fit.

Lea este manual y siga los pasos para que el producto no pierda la garantía y también para el ajuste perfecto.

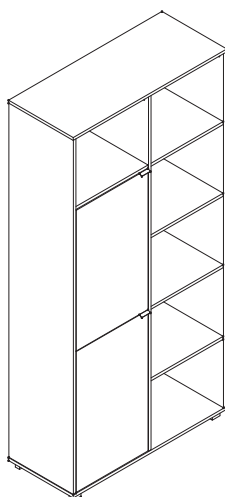

Antes de começar Before starting Antes de comenzar

Antes de começar a montagem prepare o ambiente, deixando-o completamente limpo e com bom espaço para iniciar o trabalho.

Prepare the room before starting the assembly, leaving it completely clean and the area in good condition to start the work.

Antes de comenzar el montaje preparar el ambiente, dejándolo completamente limpio y con bueno espacio para comenzar el trabajo.

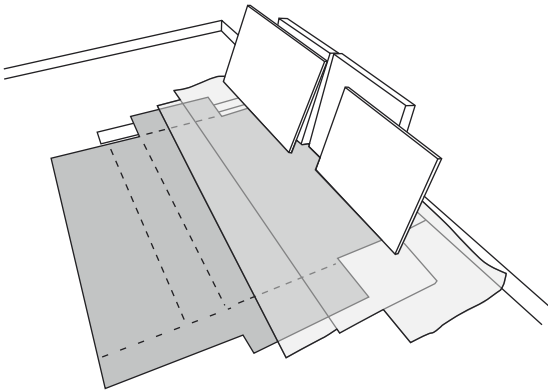

Utilize o papelão da própria embalagem para separar e apoiar as peças retiradas das caixas.

Use the cardboard of the packaging to separate and support the parts removed from the boxes.

Utilice el cartón de la embalaje para separar y apoyar las piezas desmontadas de las cajas.

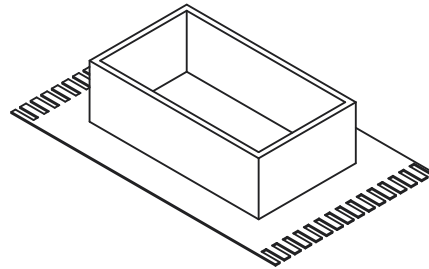

Forre a área de montagem com um cobertor ou tapete. Assim, você evita avarias nas peças durante o processo de montagem.

Cover the assembly area with a blanket or carpet to avoid damaging the parts during the assembly process.

Cubrir la zona de ensamble con una manta o alfombra. De este modo, se evitan daños en las piezas durante el proceso de montaje.



Evite acidentes Avoid accidents Prevenir accidentes

Solicitamos observar atentamente as orientações de montagem como: fixação do produto na parede, colocação de cola em locais específicos necessários, o peso suportado pelo produto, etc...

We request you to carefully observe the assembly instructions as: fixing the product on the wall, adding glue in needed and specific places, product weight limit, etc.

Pedimos que lea atentamente las instrucciones, principalmente las informaciones de fijación del producto en la pared, colocación de pegamento en local específico y necesario, el peso soportado por el producto etc...

Não escale ou se apoie no móvel.

Do not climb or lean on the furniture.

No se suba ni se apoye en el mueble.

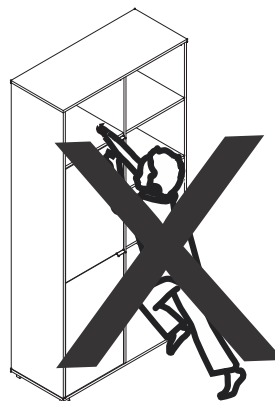

Dimensões e ferramentas
Dimensions and tools
Dimensiones y herramientas

Dimensões:

L: 900 A: 1865 P: 380 mm

Dimensions:

W: 35.43 H: 73.42 D: 14.96 inches

Dimensiones:

L: 900 A: 1865 P: 380 mm

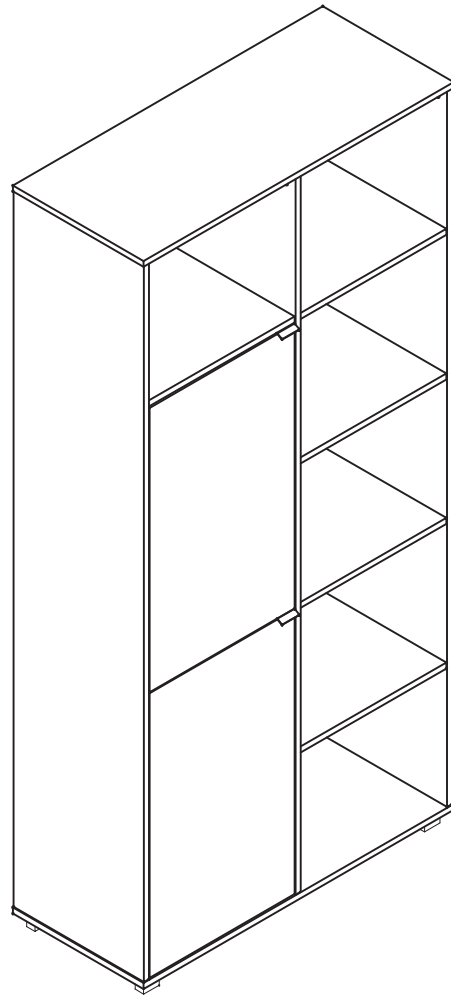

Limpeza
Cleaning
Limpieza



Pano levemente umedecido com água, seguido de pano seco, não utilizar produtos químico ou abrasivos.
Slightly dampened cloth and after a dry cloth, do not use chemicals or abrasives.
Solamente utilizar un paño húmedo y después un paño seco, no utilice productos químicos o abrasivos.

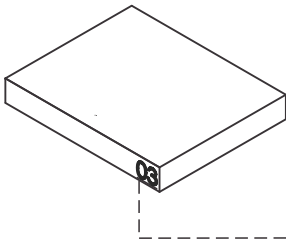

UTILIZE ALCOOL APENAS PARA REMOVER O NUMERO DAS PEÇAS
USE ALCOHOL ONLY TO REMOVE PART NUMBERS
UTILICE ALCOHOL SOLAMENTE PARA ELIMINAR EL NUMERO DE LAS PIEZAS

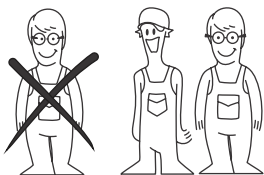

Para facilitar a montagem, utilize uma parafusadeira elétrica.
To improve assembly, use an electronic screwdriver.
Para facilitar el armado, utilice un destornillador eléctrico.

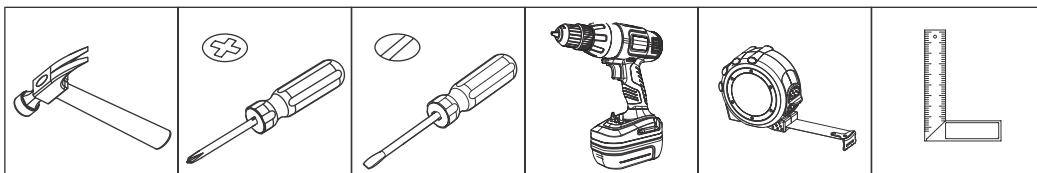

COD BR: BE 79

PEÇA	DESCRIÇÃO	QUANT.
001	BASE	1
002	TAMPO	1
003	LATERAL ESQUERDA	1
004	LATERAL DIREITA	1
005	DIVISÓRIA	1
006	PRATELEIRA	4
007	PORTA	2
008	COSTA	5
009	PRATELEIRA MENOR	4
010	PÉS	4

PART	DESCRIPTION	QTY
001	BASE	1
002	TOP	1
003	LEFT SIDE	1
004	RIGHT SIDE	1
005	PARTITION	1
006	SHELF	4
007	DOOR	2
008	BACK	5
009	LOWER SHELF	4
010	FEET	4

PIEZA	DESCRIPCIÓN	CANTIDAD
001	BASE	1
002	TAPA	1
003	LATERAL IZQUIERDA	1
004	LATERAL DERECHA	1
005	PARTICIÓN	1
006	REPISA	4
007	PUERTA	2
008	REVÉS	5
009	REPISA MENOR	4
010	PIES	4

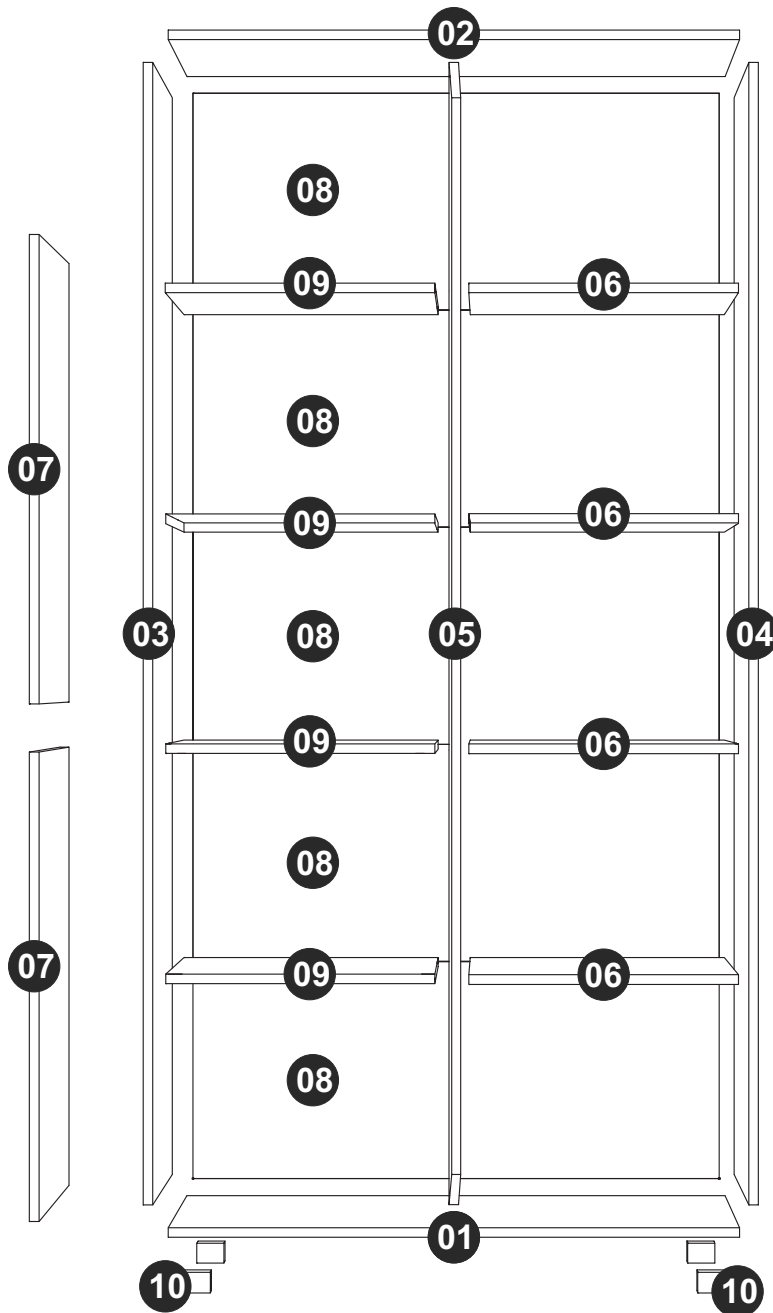

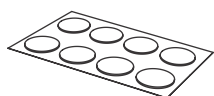

TAPA FUROS x 38
STICKER x 38
TAPAS PLÁSTICAS x 38



EF 000094 X 22

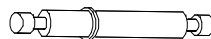

EF 000067 X 08



EF 000033 x 28
8x30



EF 000132 x 06
4X50 CC



EF 000731 x 08
8x55



EF 000216 X 38



EF 000381 x 12
3x25 CC

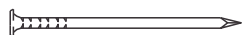

EF 000168 X 170
10x10 C/C

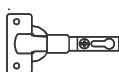

EF 000043 X 04



EF 000025 X 04



EF 000106 x 16
3,5X14 CC



PÉS RETÂNGULARES x 04
RETANGULAR FEET x 04
PIES RECTANGULARES x 04

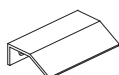

PUXADOR x 02
HANDLE x 02
MANIJA x 02

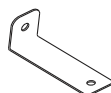

EF 000529 X 01



EF 000016 X 01



EF 000246 x 01
5X50 CF



EF 000248 X 01
3,5X14 CP



GIZ x 01
CHALK x 01
TIZA x 01

Utilize para medir as ferragens.

Utilice para medir el herraje.

Use for measuring the hardware.

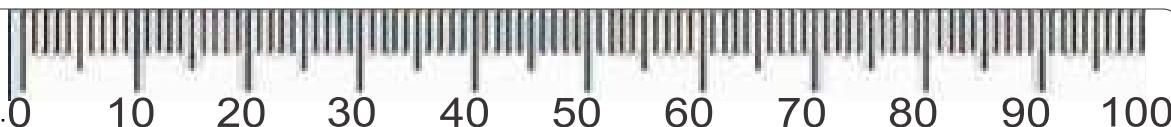

Garantia (exclusivo para o Brasil/exclusivo de Brasil/exclusive to Brazil):

A garantia dos produtos fabricados pela BRV Móveis, abrange eventuais defeitos-vícios de fabricação, no prazo estabelecido pelo código de Defesa do Consumidor, em seu artigo 26.II. o qual prevê a garantia de 90 (noventa) dias.

A = 5KG - 11.02LB

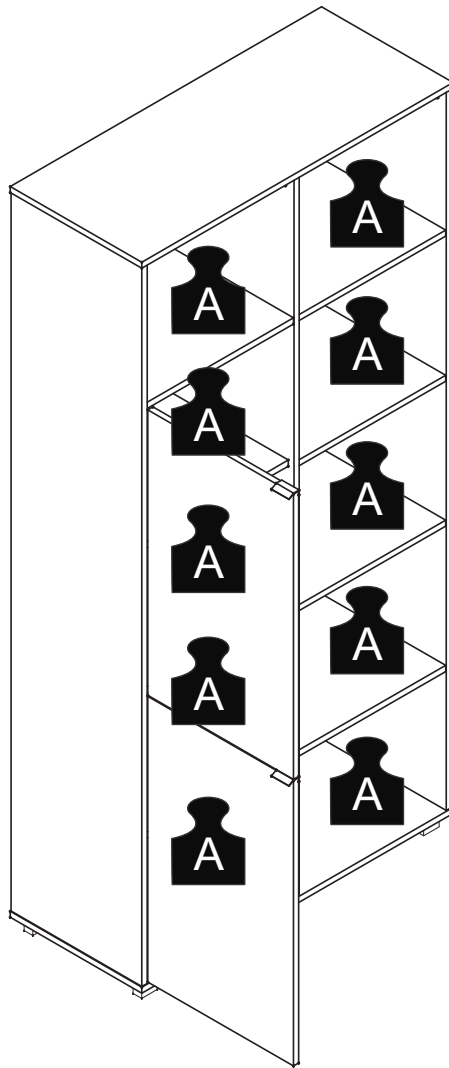

PASSO 1 / STEP 1 / PASO 1

Fixe a ferragem EF 000094 nas peças 02, 03 e 04.
Fix hardware EF 000094 in pieces 02, 03 and 04.
Fije el herraje EF 000094 en las piezas 02, 03 y 04.

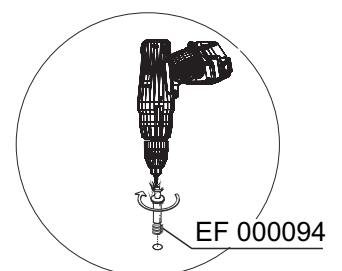
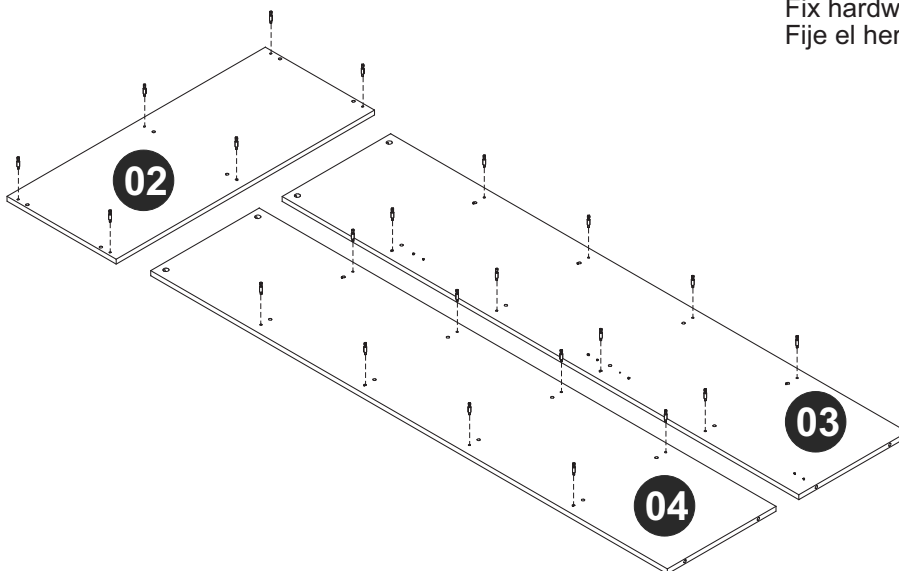

PASSO 2 / STEP 2 / PASO 2

Insira a ferragem EF 000033 nas peças 03, 04 e 05.
Fixe a ferragem EF 000025 na peça 03 usando a ferragem EF 000106.
Insert hardware EF 000033 into pieces 03, 04 and 05.
Fix hardware EF 000025 into piece 03 using hardware EF 000106.
Añade el herraje EF 000033 en las piezas 03, 04 y 05.
Fije el herraje EF 000025 en la pieza 03 utilizando el herraje EF 000106.

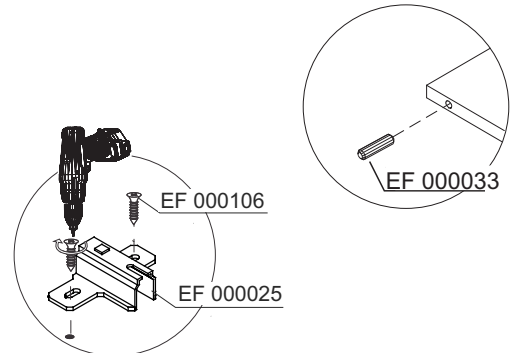
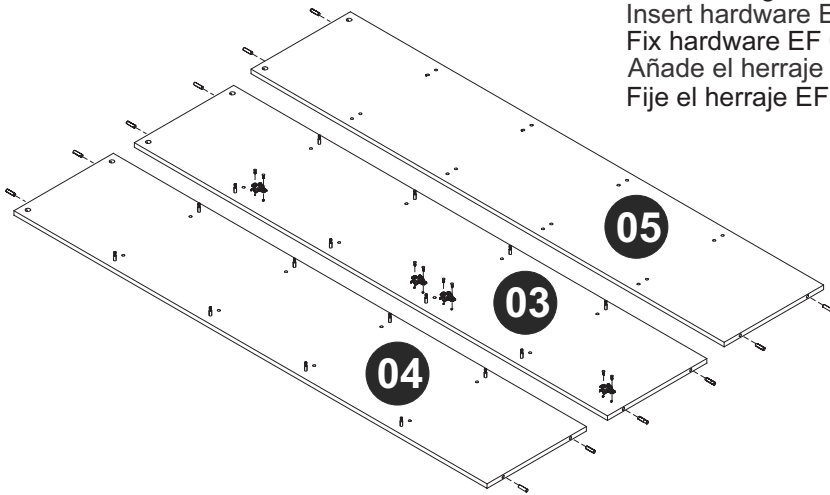

PASSO 3 / STEP 3 / PASO 3

Insira a ferragem EF 000033 nas peças 06 e 09.
Insert hardware EF 000033 into pieces 06 and 09.
Añade el herraje EF 000033 en las piezas 06 y 09.

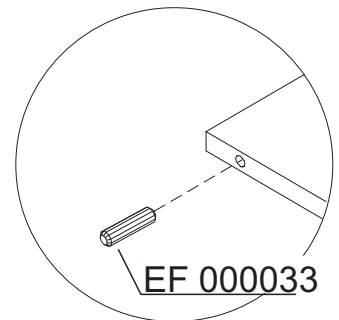
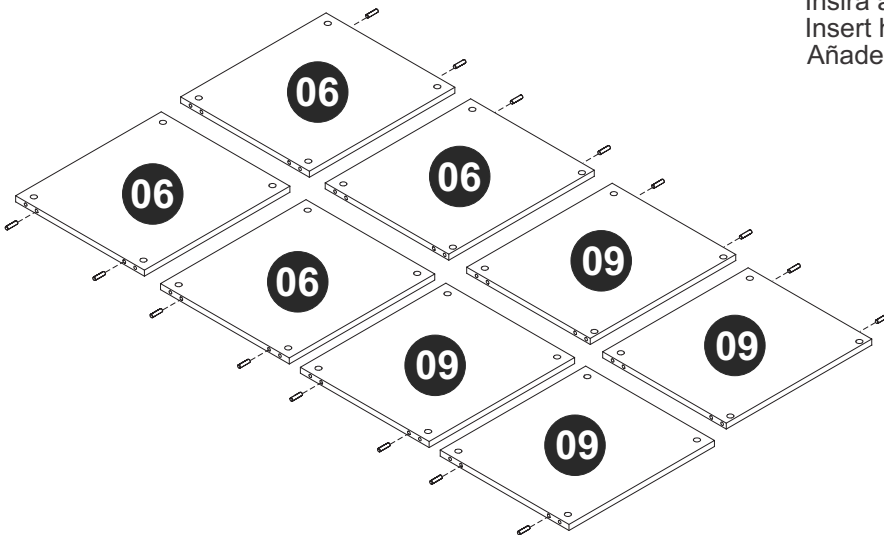

PASSO 4 / STEP 4 / PASO 4

Fixe a ferragem EF 000043 e o puxador nas peças 07 usando a ferragem EF 000106.
Fix hardware EF 000043 and the handle into pieces 07 using hardware EF 000106.
Fije el herraje EF 000043 y la manija en las piezas 07 utilizando el herraje EF 000106.

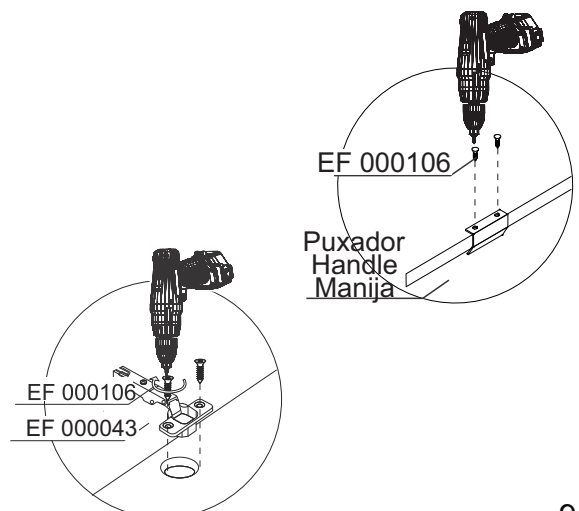
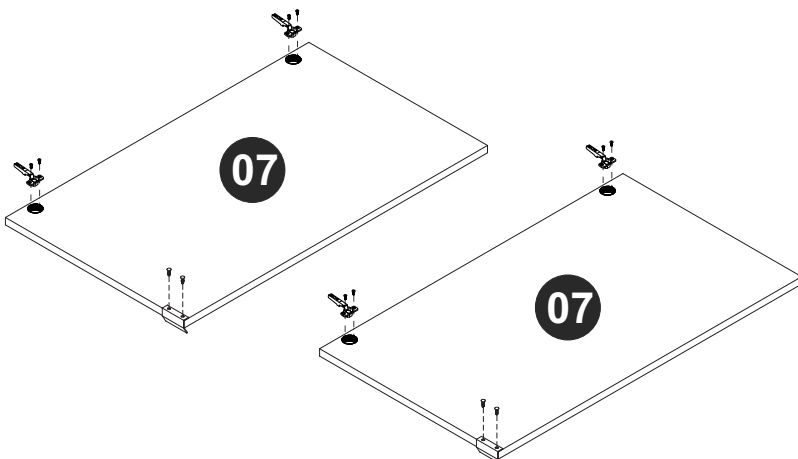

PASSO 5 / STEP 5 / PASO 5

Insira as ferragens EF 000067 e EF 000731 na peça 05, conecte as peças 06 e 09, insira a ferragem EF 000216 e gire para apertar.
Insert hardware EF 000067 and EF 000731 into piece 05, connect pieces 06 and 09, insert hardware EF 000216 and turn to tighten.
Añade el herraje EF 000067 y EF 000731 a la pieza 05, junte las piezas 06 y 09, añade el herraje EF 000216 y gire para apretar.

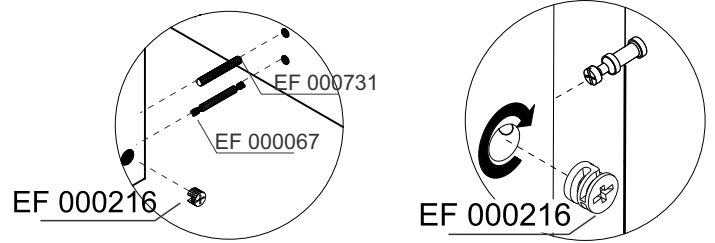
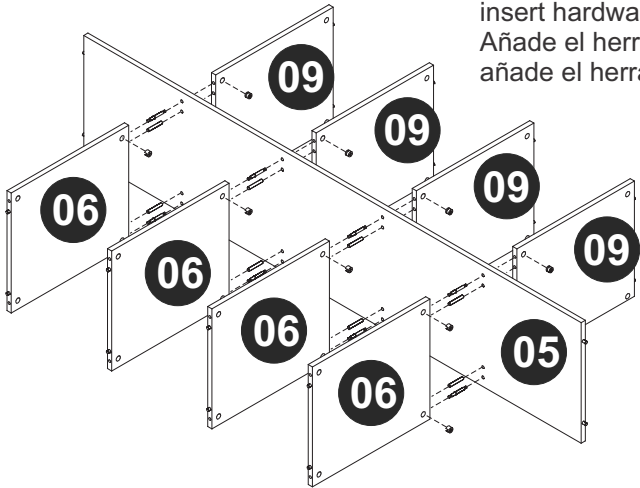

PASSO 6 / STEP 6 / PASO 6

Conecte a peça 03 á parte montada no passo anterior, insira a ferragem EF 000216 e gire para apertar.
Connect piece 03 to the part assembled into the previous step, insert hardware EF 000216 and turn to tighten.
Junte la pieza 03 a la parte armada en el paso anterior, añada el herraje EF 000216 y gire para apretar.

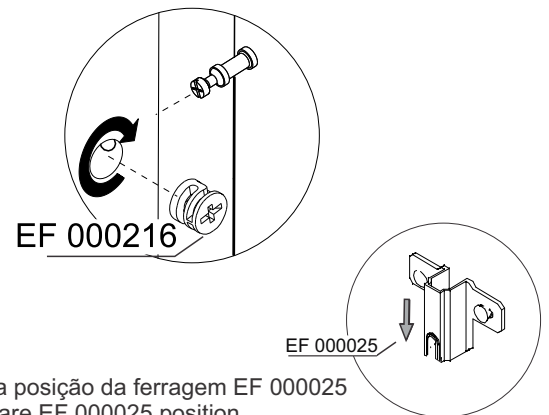
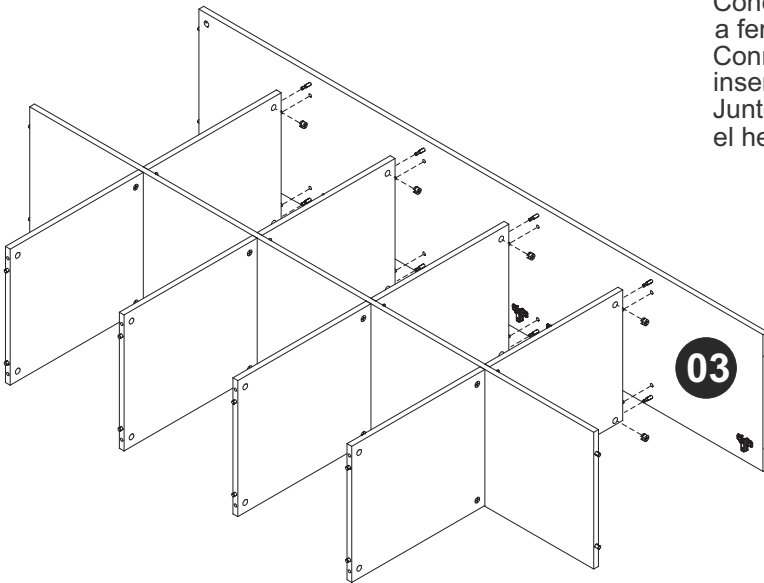

Por favor, observe a posição da ferragem EF 000025
Please, note hardware EF 000025 position.
Por favor, observe la posición del herraje EF000025.

PASSO 7 / STEP 7 / PASO 7

Conecte a peça 04 á parte montada no passo anterior, insira a ferragem EF 000216 e gire para apertar.
Connect piece 04 to the part assembled into the previous step, insert hardware EF 000216 and turn to tighten.
Junte la pieza 04 a la parte armada en el paso anterior, añada el herraje EF 000216 y gire para apretar.

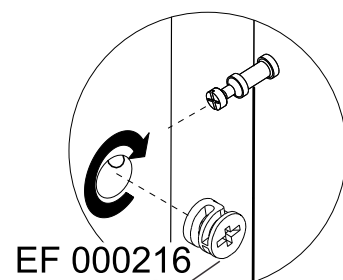
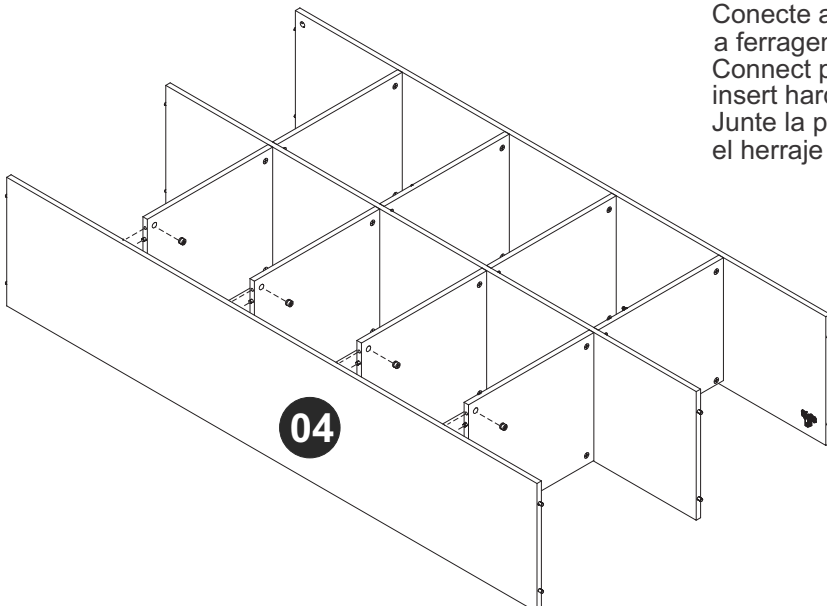

PASSO 8 / STEP 8 / PASO 8

Conecte a peça 02 á parte montada no passo anterior, insira a ferragem EF 000216 e gire para apertar.
Connect piece 02 to the part assembled into the previous step, insert hardware EF 000216 and turn to tighten.
Junte la pieza 02 a la parte armada en el paso anterior, añáde el herraje EF 000216 y gire para apretar.

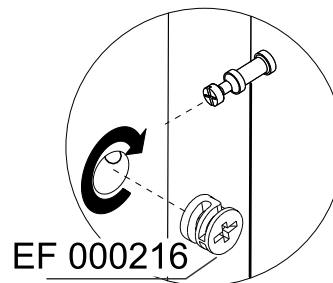
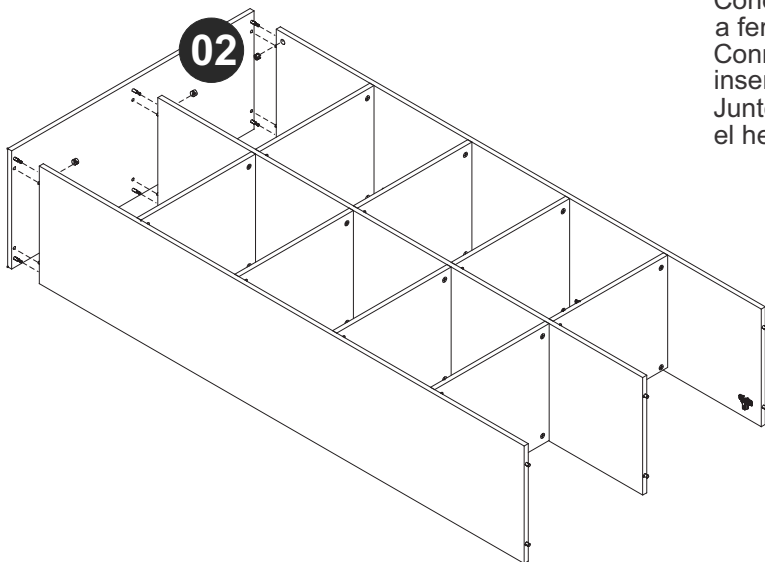

PASSO 9 / STEP 9 / PASO 9

Conecte a peça 01 ao móvel montado utilizando a ferragem EF 000132.
Connect piece 01 at the assembled furniture using hardware EF 000132.
Junte la pieza 01 al mueble armado utilizando el herraje EF 000132.

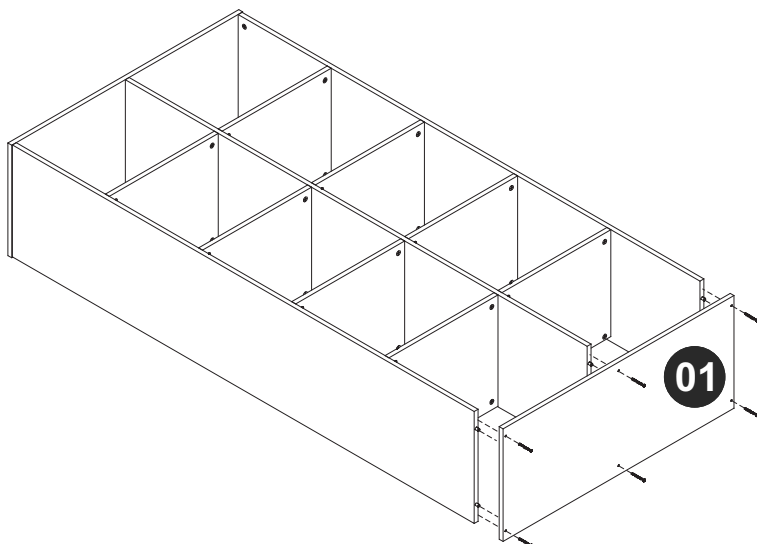

EF 000132

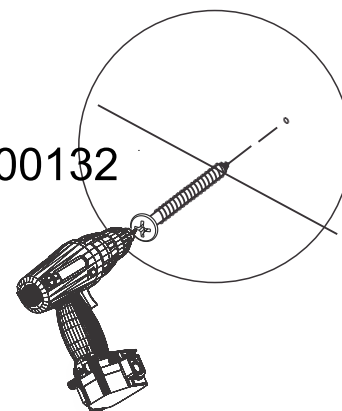

PASSO 10 / STEP 10 / PASO 10

Fixe os pés retangulares na peça 01 utilizando a ferragem EF 000381.
Fix the rectangular feet at piece 01 using hardware EF 000381.
Fije los pies rectangulares en la pieza 01 utilizando el herraje EF 000381.

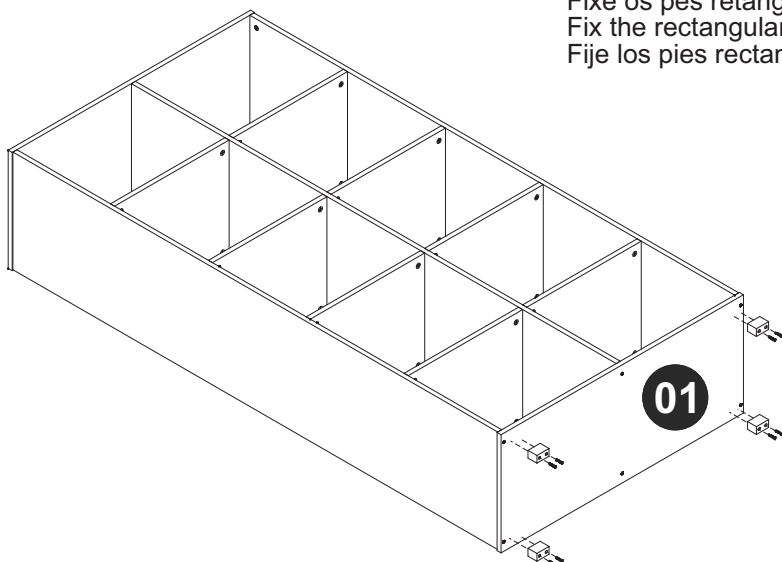

PÉS RETANGULARES
RECTANGULAR FEET
PIES RECTANGULARES

EF 000381

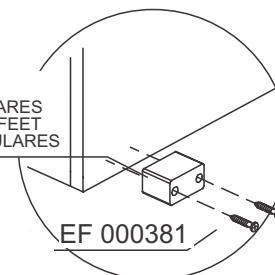

PASSO 11 / STEP 11 / PASO 11

Fixe as peças 08 utilizando a ferragem EF 000168.
Fix the pieces 08 using hardware EF 000168.
Fije las piezas 08 utilizando el herraje EF 000168.

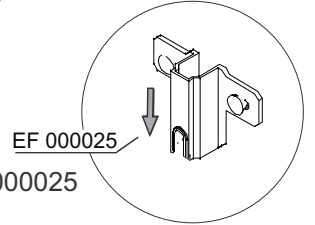
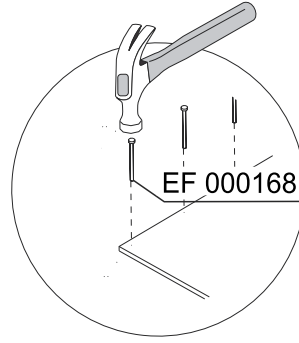
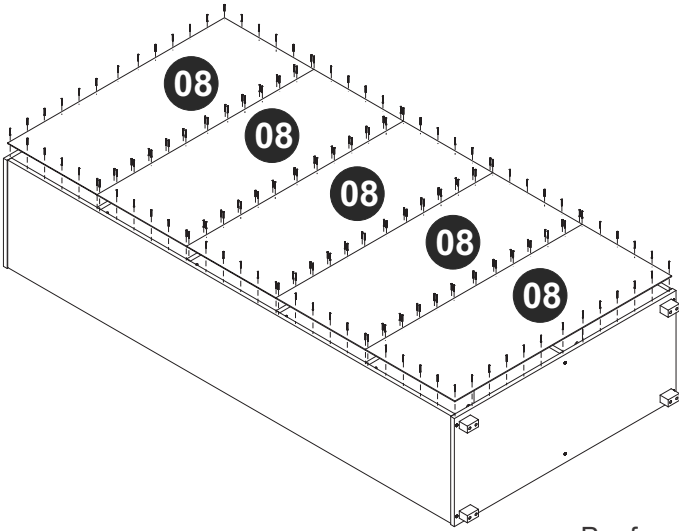

Por favor, observe a posição da ferragem EF 000025
Please, note hardware EF 000025 position.
Por favor, observe la posición del herraje EF000025.

PASSO 12 / STEP 12 / PASO 12

Fixe as peças 07 ao móvel montado.
Fix pieces 07 to the assembled furniture.
Fije las piezas 07 al mueble armado.

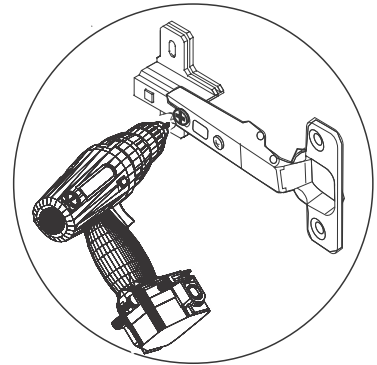
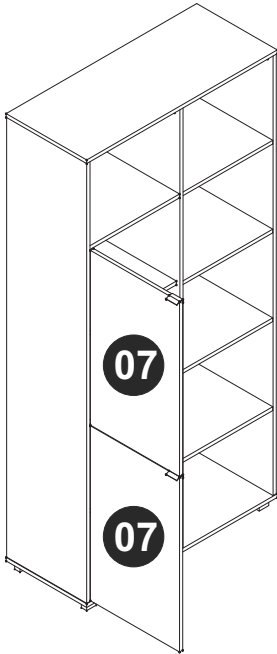

PASSO 13 / STEP 13 / PASO 13

Use o parafuso EF 000248 para fixar a ferragem EF 000529 ao móvel.
Use hardware EF 000248 to fix the hardware EF 000529 at the furniture.
Utilice el herraje EF 000248 para fijar el herraje EF000529 al mueble.

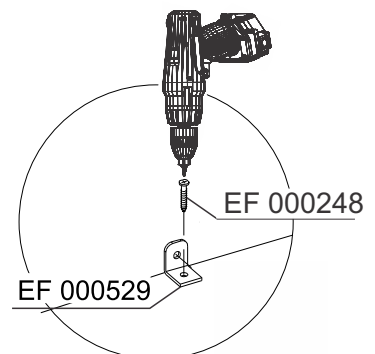
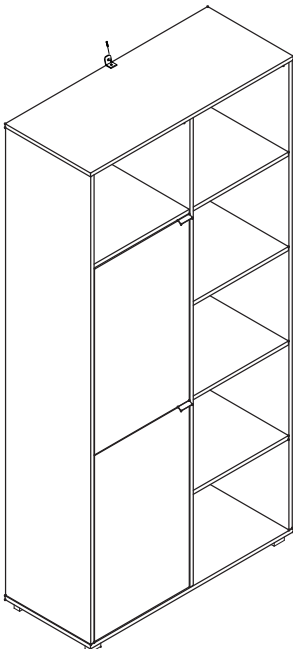

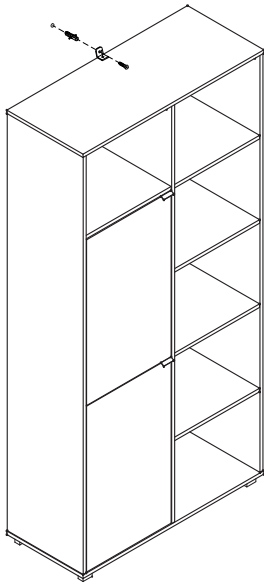

PASSO 14 / STEP 14 / PASO 14

Use as ferragens EF 000246 e EF 000016 para fixar o móvel na parede.
Use hardware EF 000246 and EF 000016 for fixing the furniture on the wall.
Utilice los herrajes EF000246 y EF000016 para fijar el mueble en la pared.

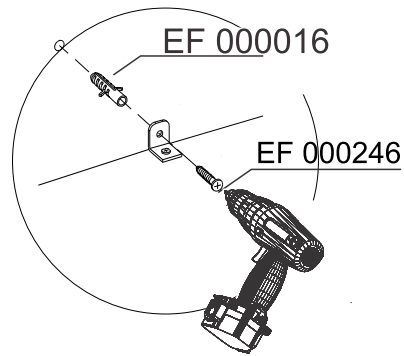

PASSO 15 / STEP 15 / PASO 15

Utilize o tapa furos para cobrir os parafusos aparentes.
Use the sticker to cover the apparent screws.
Utilice los tapa huecos para cubrir los tornillos aparentes.

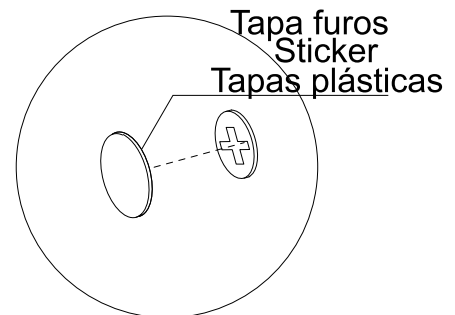
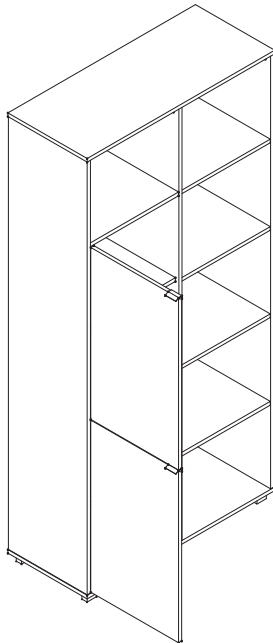

PASSO 16 / STEP 16 / PASO 16

Utilize o giz para dar o acabamento final ao produto.
Use the chalk to give the final finish on the product.
Utilice la tiza para dar el acabado final al producto.

