



MANUAL DE MONTAGEM  
ASSEMBLY INSTRUCTIONS  
INSTRUCCIONES DE MONTAJE

COD BR: BMU 61



# Sumário Summary Resumen

Introdução Introduction Introducción	.....	3
Antes de começar Before starting Antes de comenzar	.....	4
Evite acidentes Avoid accidents Evitar accidentes	.....	4
Dimensões e ferramentas Dimensions and tools Dimensiones y herramientas	.....	5
Identificação das peças Identifying parts Identificación de las piezas	.....	6
Acessórios incluídos na caixa Hardware included in box Accesorios incluidos en la caja	.....	7
Montagem do móvel Furniture assembly Montaje del mueble	.....	8

## Introdução Introduction Introducción

Leia atentamente este manual e siga os passos indicados para que o produto não perca a garantia e também para uma perfeita montagem.

Read this manual and follow the steps in order to keep the guarantee and also for the perfect fit.

Lea este manual y siga los pasos para que el producto no pierda la garantía y también para el ajuste perfecto.

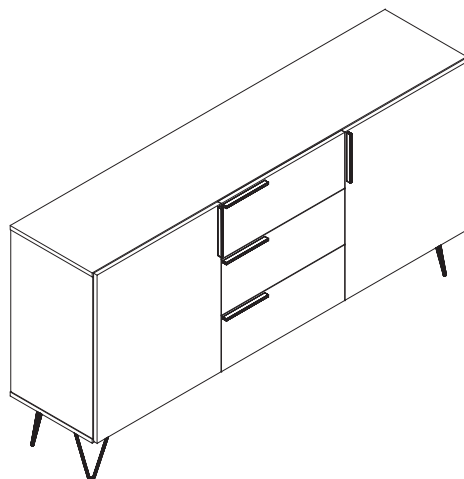

## Antes de começar Before starting Antes de comenzar

Antes de começar a montagem prepare o ambiente, deixando-o completamente limpo e com bom espaço para iniciar o trabalho.

Prepare the room before starting the assembly, leaving it completely clean and the area in good condition to start the work.

Antes de comenzar el montaje preparar el ambiente, dejándolo completamente limpio y con bueno espacio para comenzar el trabajo.

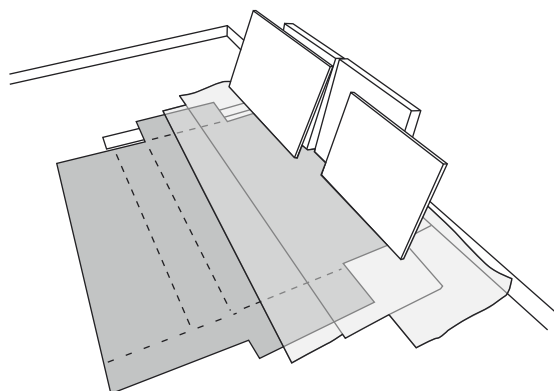

Utilize o papelão da própria embalagem para separar e apoiar as peças retiradas das caixas.

Use the cardboard of the packaging to separate and support the parts removed from the boxes.

Utilice el cartón de la embalaje para separar y apoyar las piezas desmontadas de las cajas.

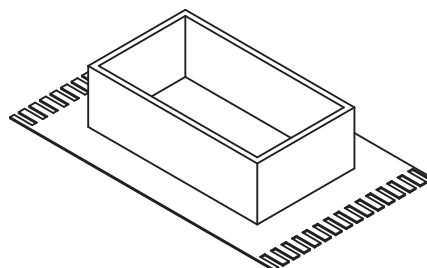

Forre a área de montagem com um cobertor ou tapete. Assim, você evita avarias nas peças durante o processo de montagem.

Cover the assembly area with a blanket or carpet to avoid damaging the parts during the assembly process.

Cubrir la zona de ensamble con una manta o alfombra. De este modo, se evitan daños en las piezas durante el proceso de montaje.



---

## Evite acidentes Avoid accidents Prevenir accidentes

Solicitamos observar atentamente as orientações de montagem como: fixação do produto na parede, colocação de cola em locais específicos necessários, o peso suportado pelo produto, etc...

You are requested to carefully observe the assembly instructions regarding: fixing of products to the wall, adding glue where indicated, product weight limit, etc.

Pedimos que lea atentamente las instrucciones, principalmente las informaciones de fijación del producto en la pared, colocación de pegamento en local específico y necesario, el peso soportado por el producto etc...

Não escale ou se apoie no móvel.

Do not climb or lean on the furniture.

No se suba ni se apoye en el mueble.

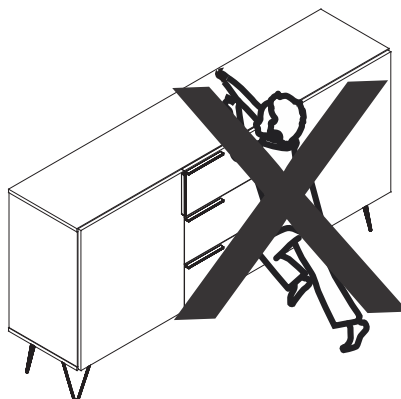

Dimensões e ferramentas  
Dimensions and tools  
Dimensiones y herramientas

Dimensões:

L: 1600 A: 810 P: 350 mm

Dimensions:

W: 62.99 H: 31.88 D: 13.77 inches

Dimensiones:

L: 1600 A: 810 P: 350 mm

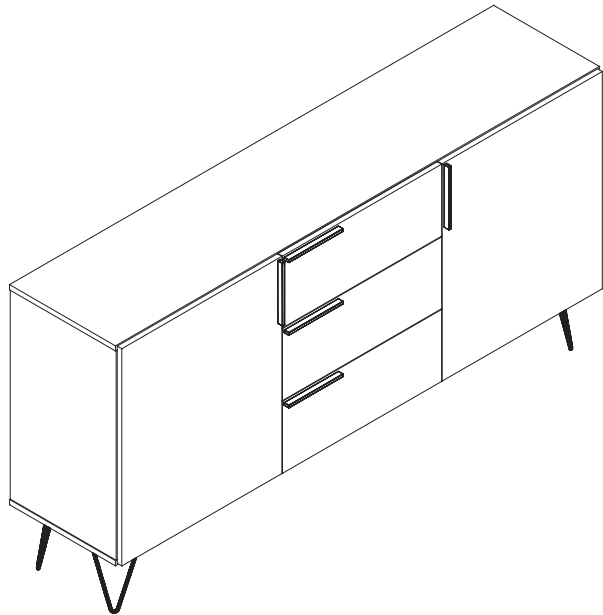

Limpeza  
Cleaning  
Limpieza

Pano levemente umedecido com água, seguido de pano seco, não utilizar produtos químico ou abrasivos.  
You can clean the product with slightly dampened cloth followed by a dry cloth. Do not use chemicals or abrasives.  
Solamente utilizar un paño húmedo y después un paño seco, no utilice productos químicos o abrasivos.

Todas as peças do móvel foram marcadas com um número. Antes de começar a montagem, identifique as peças numeradas em relação às instruções de montagem. Uma vez concluída a montagem, os números podem ser facilmente removidos com um pano ligeiramente embebido em álcool. Use álcool apenas para remover números das peças.

All the furniture parts have been marked with a number. Before you start assembling, please identify the numbered parts in relation to the assembly instructions. Once assembly is completed, the numbers can be easily removed with a cloth slightly damped in alcohol. Use alcohol only to remove part numbers.

Todos las piezas del mueble fueron marcadas con un número. Antes de empezar el montaje, identifique las piezas numeradas en relación con las instrucciones de montaje. Una vez que se completa el armado, los números se pueden quitar fácilmente con un paño ligeramente empapado en alcohol. Use alcohol solo para eliminar números de las piezas.

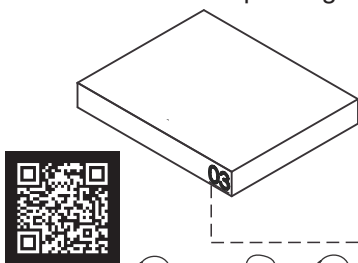

**UTILIZE ALCOOL APENAS PARA REMOVER O NUMERO DAS PEÇAS**  
**USE ALCOHOL ONLY TO REMOVE PART NUMBERS**  
**UTILICE ALCOHOL SOLAMENTE PARA ELIMINAR EL NUMERO DE LAS PIEZAS**

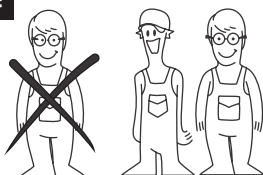

Para facilitar a montagem, utilize uma parafusadeira elétrica.  
To speed assembly, use an electronic screwdriver.  
Para facilitar el armado, utilice un destornillador eléctrico.

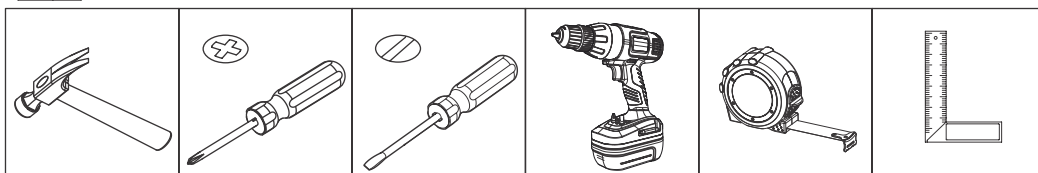

# COD BR: BMU 61

PEÇA	DESCRIÇÃO	QUANT.	PART DESCRIPTION	QTY	PIEZA DESCRIPCIÓN	CANTIDAD
001	BASE	1	001 BASE	1	001 BASE	1
002	TAMPO	1	002 TOP	1	002 TAPA	1
003	LATERAL ESQUERDA	1	003 LEFT SIDE	1	003 LATERAL IZQUIERDA	1
004	LATERAL DIREITA	1	004 RIGHT SIDE	1	004 LATERAL DERECHA	1
005	DIVISÓRIA DIREITA	1	005 RIGHT PARTITION	1	005 PARTICIÓN DERECHA	1
006	DIVISÓRIA ESQUERDA	1	006 LEFT PARTITION	1	006 PARTICIÓN IZQUIERDA	1
007	PRATELEIRA	2	007 SHELF	2	007 REPISA	2
008	FRENTE GAVETA	3	008 FRONT DRAWER	3	008 FRENTE CAJÓN	3
009	PORTA ESQUERDA	1	009 LEFT DOOR	1	009 PUERTA IZQUIERDA	1
010	PORTA DIREITA	1	010 RIGHT DOOR	1	010 PUERTA DERECHA	1
011	FUNDO GAVETA	3	011 BOTTOM DRAWER	3	011 FONDO CAJÓN	3
012	COSTA	6	012 BACK	6	012 REVÉS	6
020	LATERAL DIREITA GAVETA	3	020 RIGHT SIDE DRAWER	3	020 LATERAL DERECHA CAJÓN	3
021	COSTA GAVETA	3	021 BACK DRAWER	3	021 REVÉS CAJÓN	3
022	LATERAL ESQUERDA GAVETA	3	022 LEFT SIDE DRAWER	3	022 LATERAL IZQUIERDA CAJÓN	3
023	PÉS	4	023 FEET	4	023 PIES	4

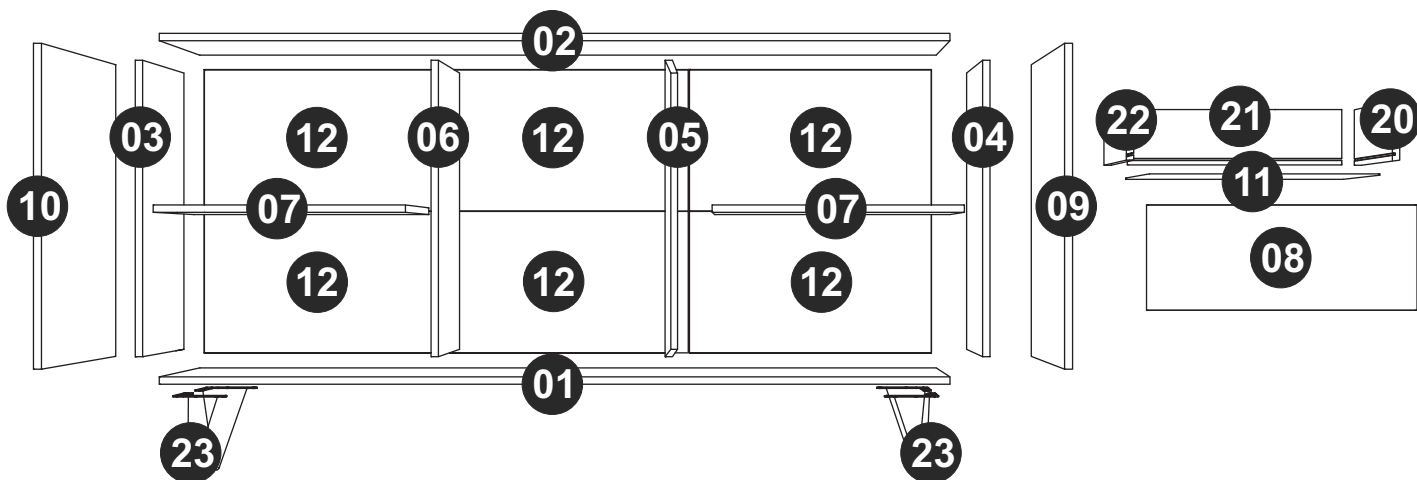



EF 000094 X 28



EF 000033 x 48  
8x30



EF 000216 X 28



EF 000106 X 56  
3,5X14 CC

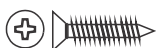

EF 000381 x 10  
3X25 CC



EF 000132 x 08  
4X50 CC

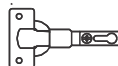

EF 000044 X 04



EF 000024 X 04

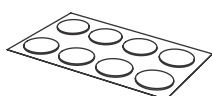

TAPA FUROS x 28  
STICKER x 28  
TAPAS PLÁSTICAS x 28



CORREDIÇA x 06  
DRAWER TRAKS x 06  
CORREDERAS x 06



PUXADOR x 05  
HANDLE x 05  
MANIJA x 05



EF 000168 X 120  
10X10 C/C



GIZ x 01  
CHALK x 01  
TIZA x 01

Utilize para medir as ferragens.

Utilice para medir el herraje.

Use for measuring the hardware.

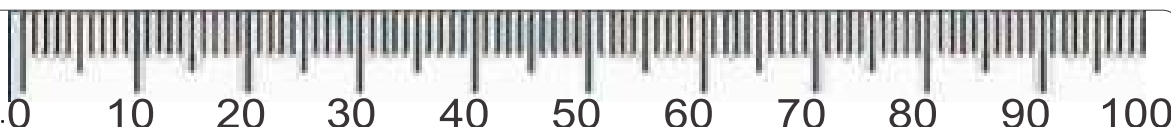

**Garantia (exclusivo para o Brasil/exclusivo de Brasil/exclusive to Brazil):**

A garantia dos produtos fabricados pela BRV Móveis, abrange eventuais defeitos-vícios de fabricação, no prazo estabelecido pelo código de Defesa do Consumidor, em seu artigo 26.II. o qual prevê a garantia de 90 (noventa) dias.

**A** = 20KG - 44.09 LB

**B** = 6KG - 13.22 LB

**C** = 3KG - 6.61 LB

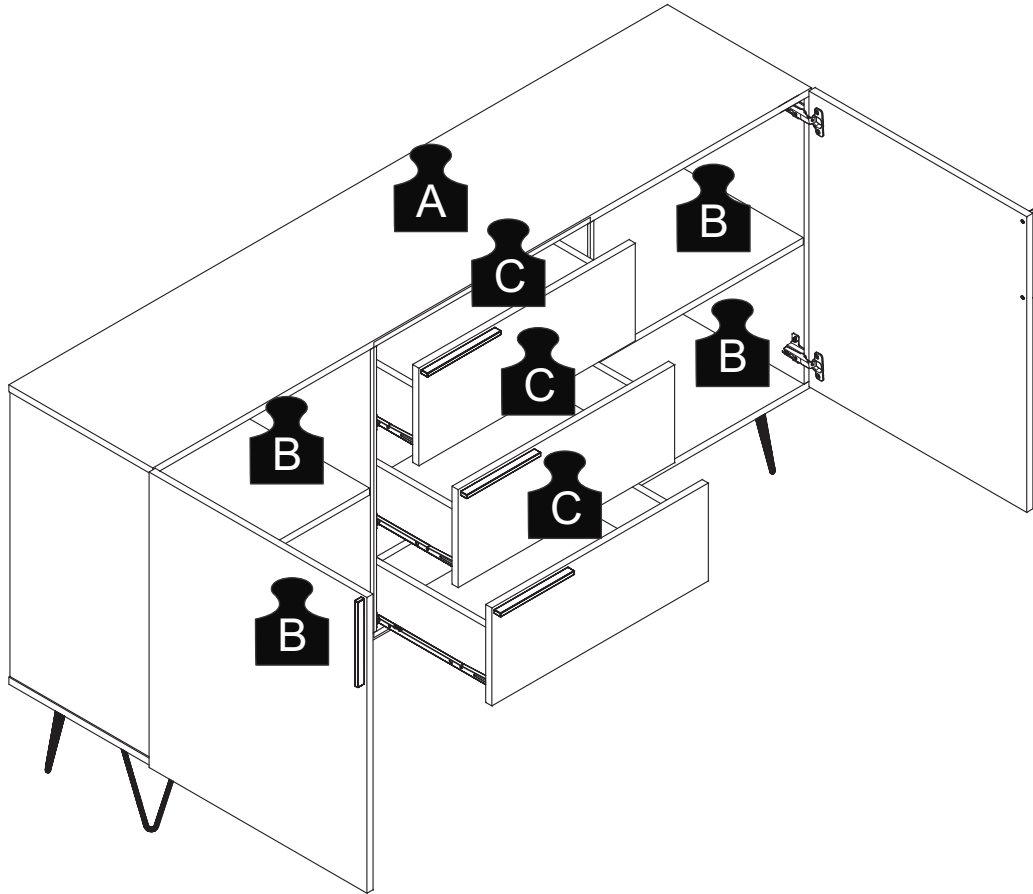

**PASSO 1 / STEP 1 / PASO 1**

Insira a ferragem EF 000094 nas peças 02, 08, 20 e 22.  
Insert hardware EF 000094 into pieces 02, 08, 20 and 22.  
Añade el herraje EF 000094 en las piezas 02, 08, 20 y 22.

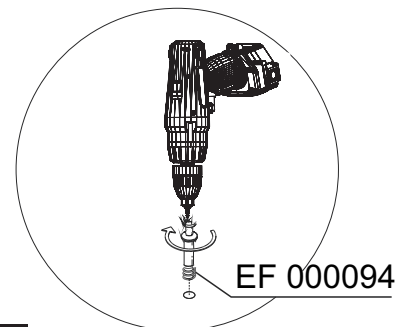
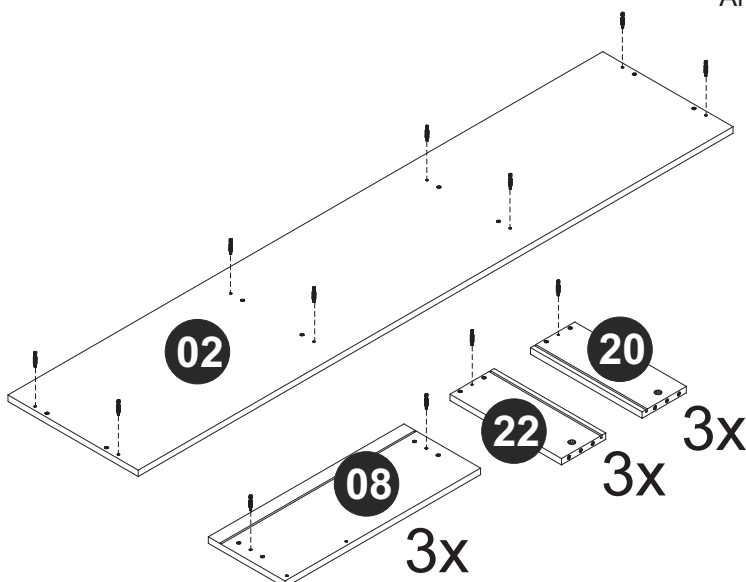



## PASSO 2 / STEP 2 / PASO 2

Insira a ferragem EF 000033 nas peças 07, 20, 21 e 22.  
Insert hardware EF 000033 into pieces 07, 20, 21 and 22.  
Añade el herraje EF 000033 en las piezas 07, 20, 21 y 22.

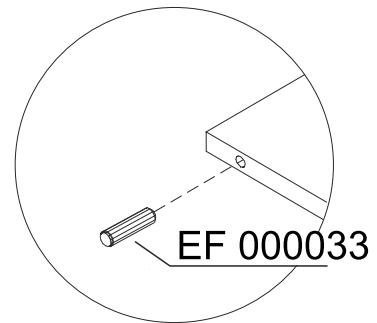
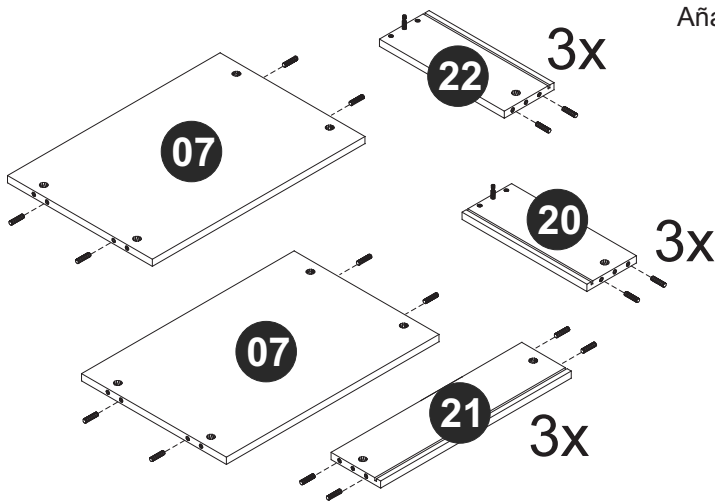

## PASSO 3 / STEP 3 / PASO 3

Insira a ferragem EF 000094 e EF 000033 nas peças 03, 04, 05 e 06.  
Insert hardware EF 000094 and EF 000033 into pieces 03, 04, 05 and 06.  
Añade el herraje EF 000094 y EF 000033 en las piezas 03, 04, 05 y 06.

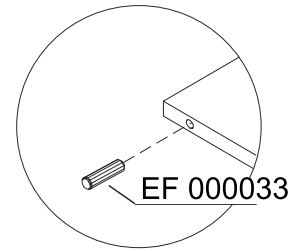
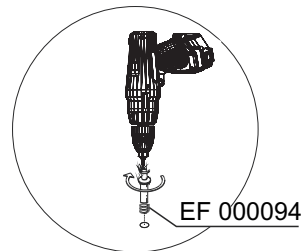
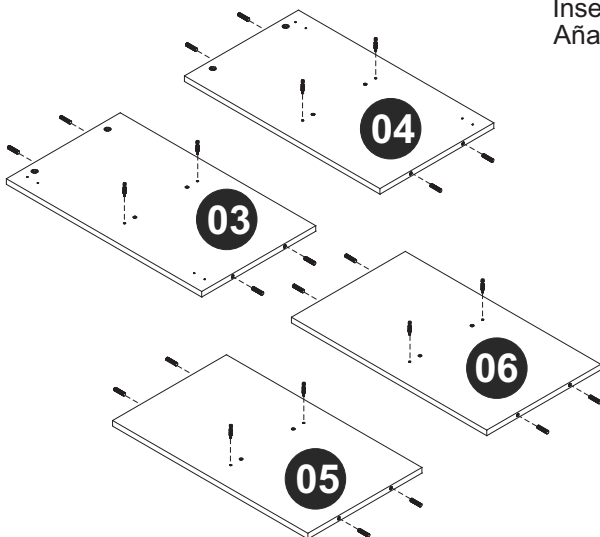

## PASSO 4 / STEP 4 / PASO 4

Fixe a ferragem EF 000024 nas peças 03 e 04 utilizando a ferragem EF 000106.  
Attach hardware EF 000024 into pieces 03 and 04 using hardware EF 000106.  
Fije el herraje EF 000024 en las piezas 03 y 04 utilizando el herraje EF 000106.

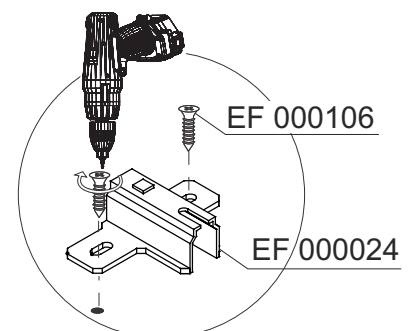
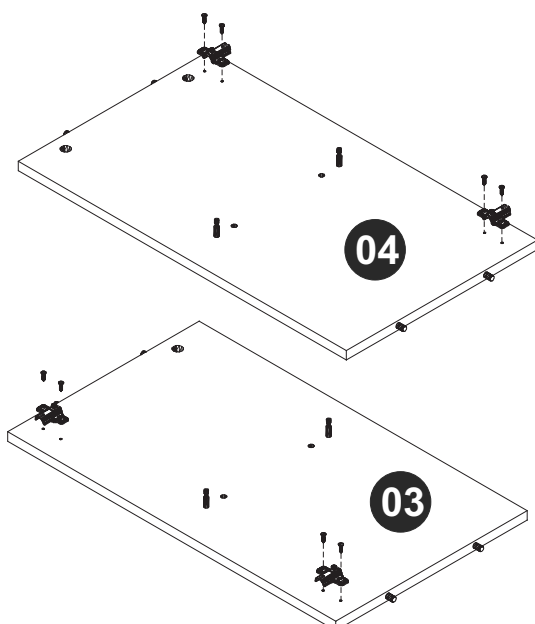

### PASSO 5 / STEP 5 / PASO 5

Fixe as corrediças nas peças 05 e 06 utilizando a ferragem EF 000106.  
Attach the drawer tracks into pieces 05 and 06 using hardware EF 000106.  
Fije las correderas en las piezas 05 y 06 utilizando el herraje EF 000106.

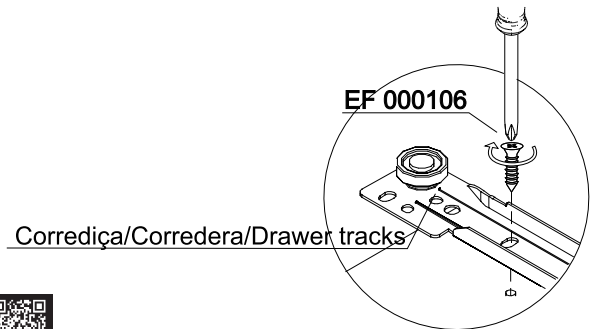
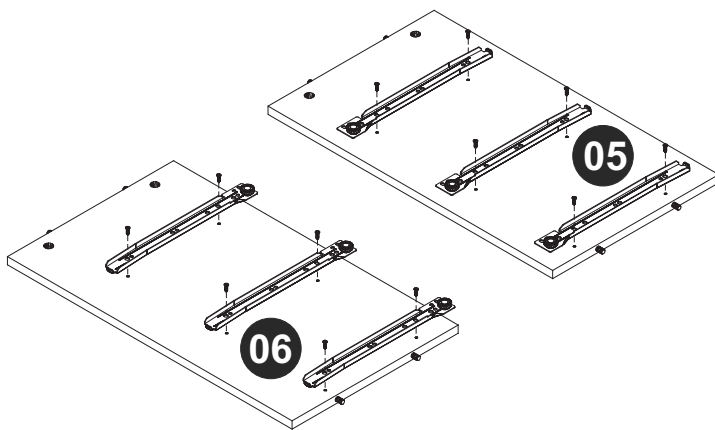

### PASSO 6 / STEP 6 / PASO 6

Fixe a ferragem EF 000044 usando a ferragem EF 000106.  
Fixe o puxador usando a ferragem EF 000381.  
Fix hardware EF 000044 using hardware EF 000106.  
Fix the handle using hardware EF 000381.  
Fije el herraje EF 000044 utilizando el herraje EF 000106.  
Fije la manija utilizando el herraje EF 000381.

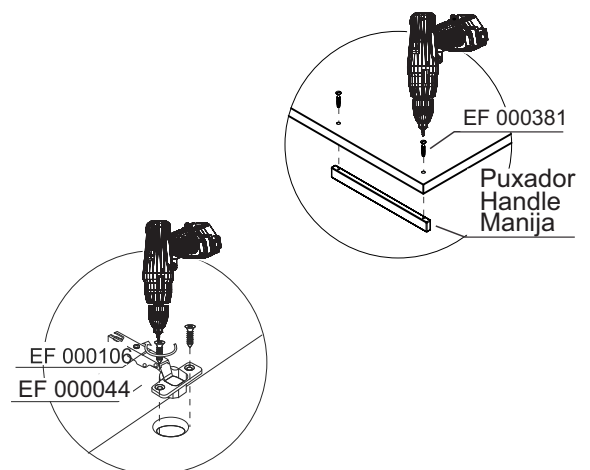
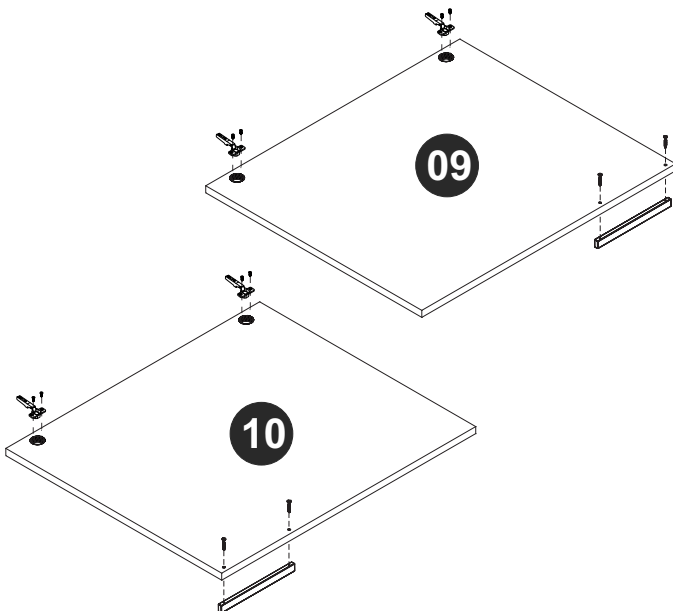

### PASSO 7 / STEP 7 / PASO 7

Conecte as peças 03, 06 e 07, insira a ferragem EF 000216 e gire para apertar.  
Connect pieces 03, 06 and 07 insert hardware EF 000216 and turn to tighten.  
Junte las piezas 03, 06 y 07, añade el herraje EF 000216 y gire para apretar.

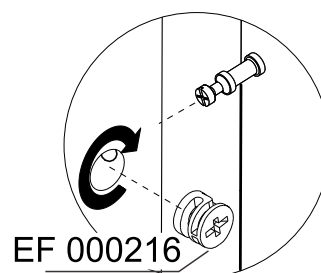
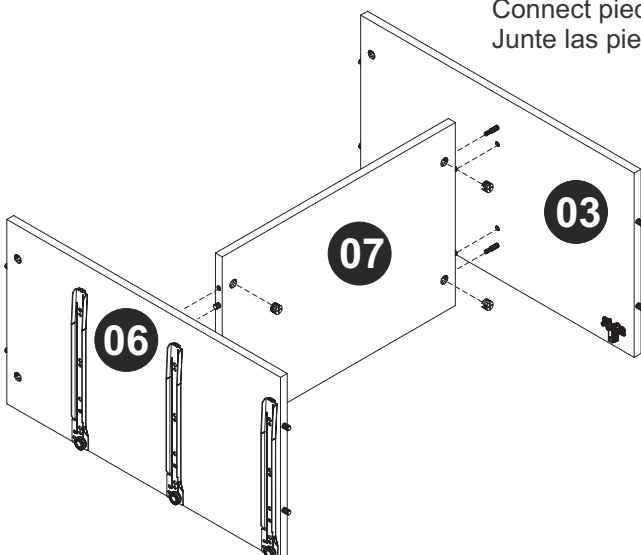

Por favor, note a posição das corrediças  
Please, note the drawer tracks position  
Por favor, notar la posición de las correderas

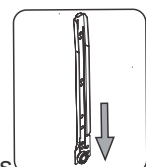

### PASSO 8 / STEP 8 / PASO 8

Conecte as peças 04, 05 e 07, insira a ferragem EF 000216 e gire para apertar.  
Connect pieces 04, 05 and 07 insert hardware EF 000216 and turn to tighten.  
Junte las piezas 04, 05 y 07, añade el herraje EF 000216 y gire para apretar.

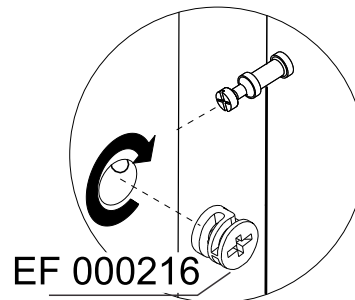
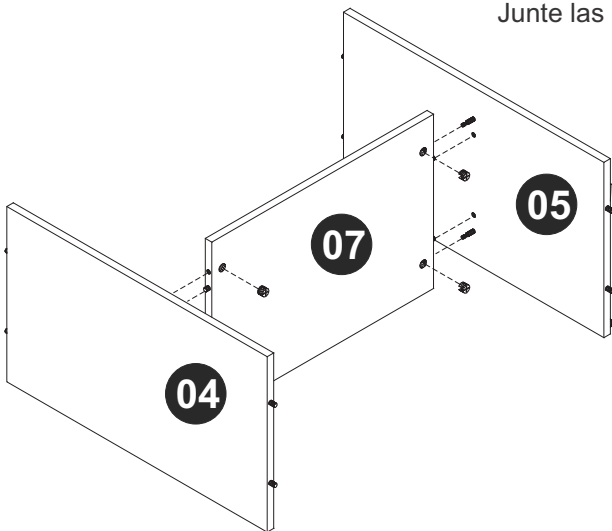

Por favor, note a posição das corredeiras  
Please, note the drawer tracks position  
Por favor, notar la posición de las correderas

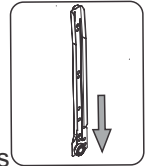

### PASSO 9 / STEP 9 / PASO 9

Conecte a peça 02 à parte montada no passo anterior, insira a ferragem EF 000216 e gire para apertar.  
Connect piece 02 to the part assembled into the previous step, insert hardware EF 000216 and turn to tighten.  
Junte la pieza 02 a la parte armada en el paso anterior, añade el herraje EF 000216 y gire para apretar.

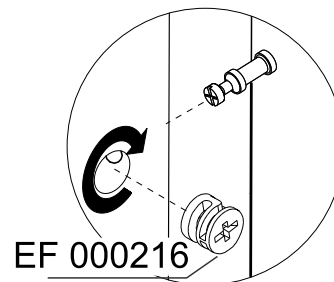
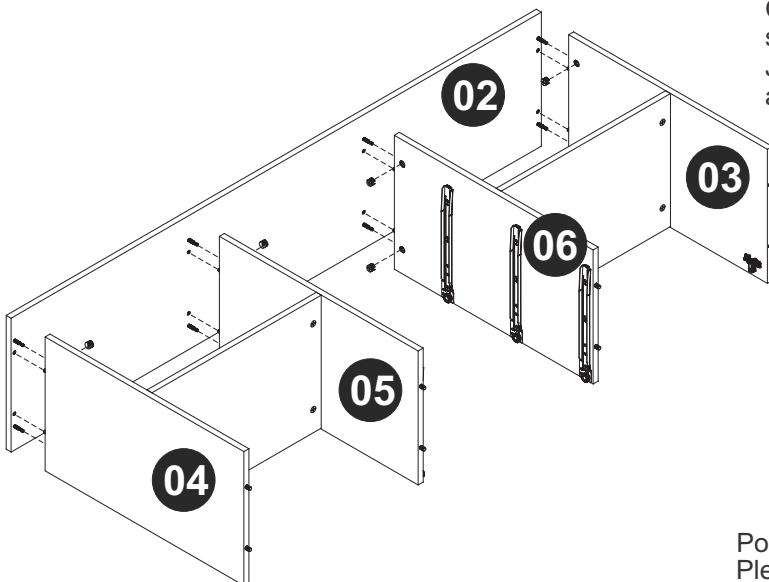

Por favor, note a posição das corredeiras  
Please, note the drawer tracks position  
Por favor, notar la posición de las correderas

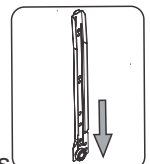

### PASSO 10 / STEP 10 / PASO 10

Fixe os pés (peças 23) na peça 01 utilizando a ferragem EF 000106.  
Fix the feet (pieces 23) at piece 01 using hardware EF 000106.  
Fije los pies (piezas 23) en la pieza 01 utilizando el herraje EF 000106.

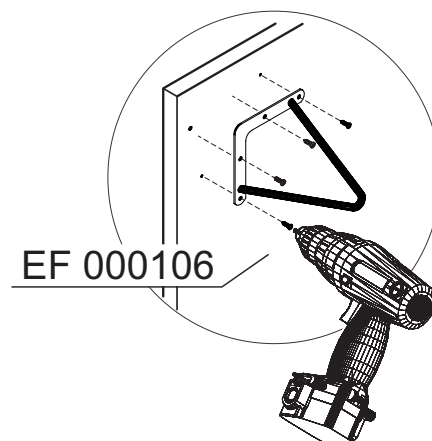
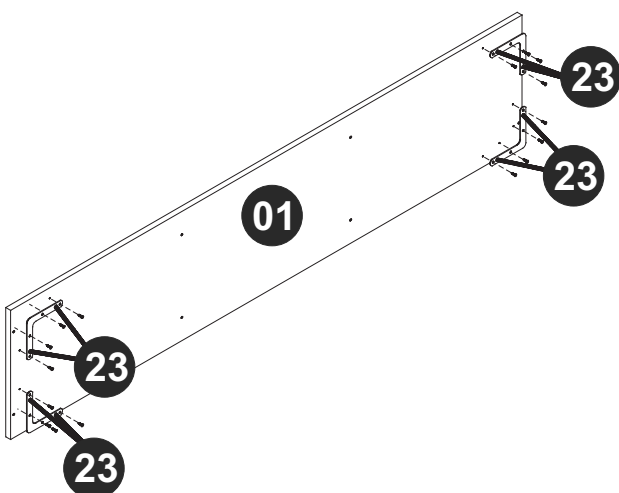

### PASSO 11 / STEP 11 / PASO 11

Conecte a peça 01 ao móvel montado utilizando a ferragem EF 000132.

Connect piece 01 at the assembled furniture using hardware EF 000132.

Junte la pieza 01 al mueble armado utilizando el herraje EF 000132.

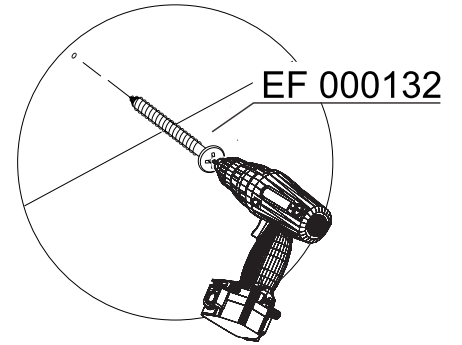
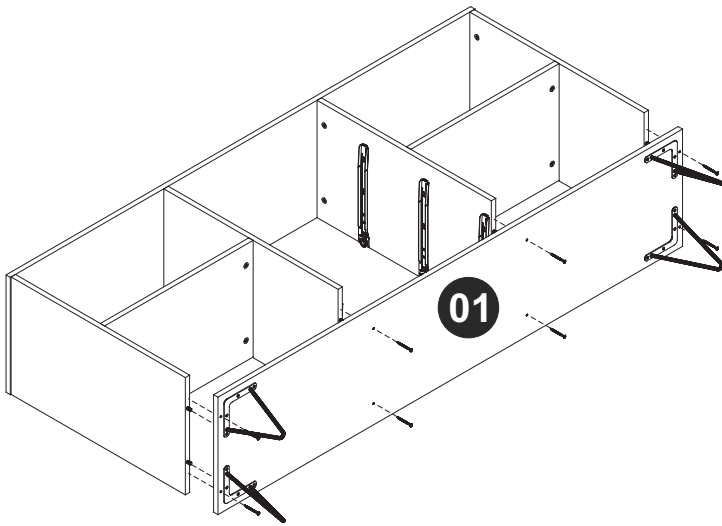

### PASSO 12 / STEP 12 / PASO 12

Fixe as peças 12 utilizando a ferragem EF 000168.

Fix the pieces 12 using hardware EF 000168.

Fije las piezas 12 utilizando el herraje EF 000168.

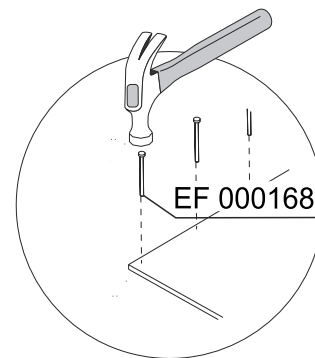
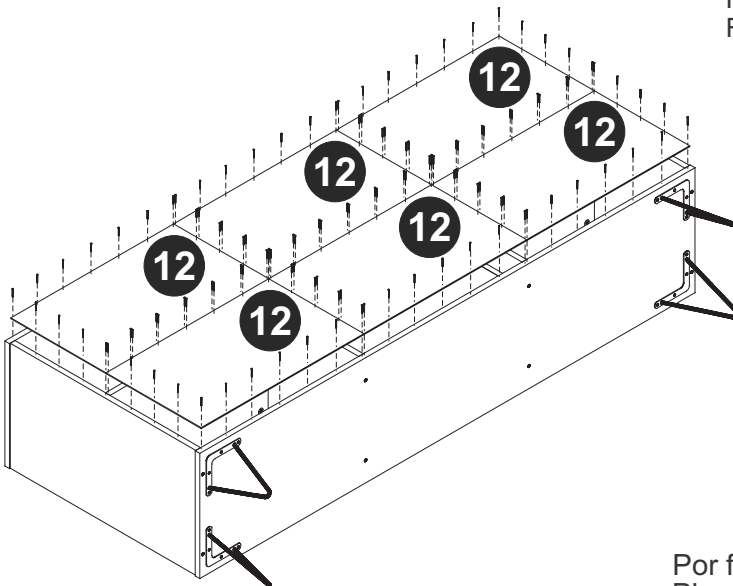

Por favor, note a posição das corredeiras  
Please, note the drawer tracks position  
Por favor, notar la posición de las correderas

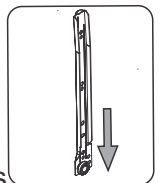

### PASSO 13 / STEP 13 / PASO 13

Conecte as peças 20, 21 e 22, insira a ferragem EF 000216 e gire para apertar.

Connect pieces 20, 21 and 22 insert hardware EF 000216 and turn to tighten.

Junte las piezas 20, 21 y 22, añade el herraje EF 000216 y gire para apretar.

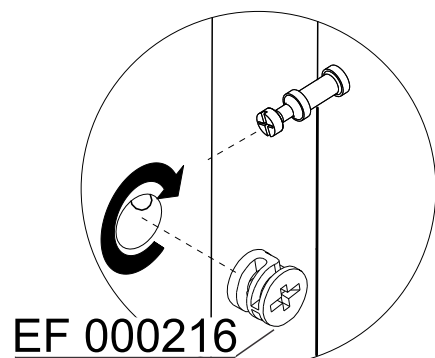
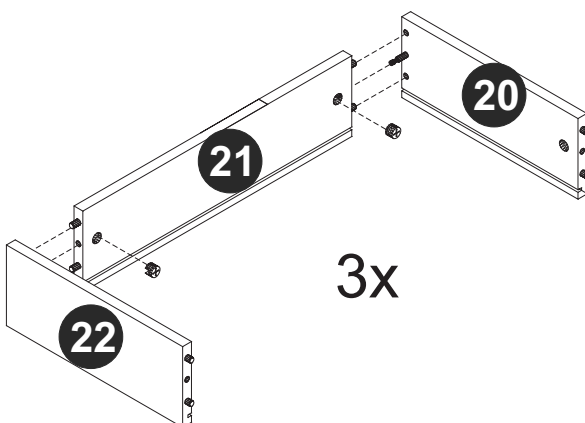

### PASSO 14 / STEP 14 / PASO 14

Encaixe a peça 11 entre os espaços específicos.  
Fix piece 11 through the specific space.  
Fije la pieza 11 entre los espacios específicos.

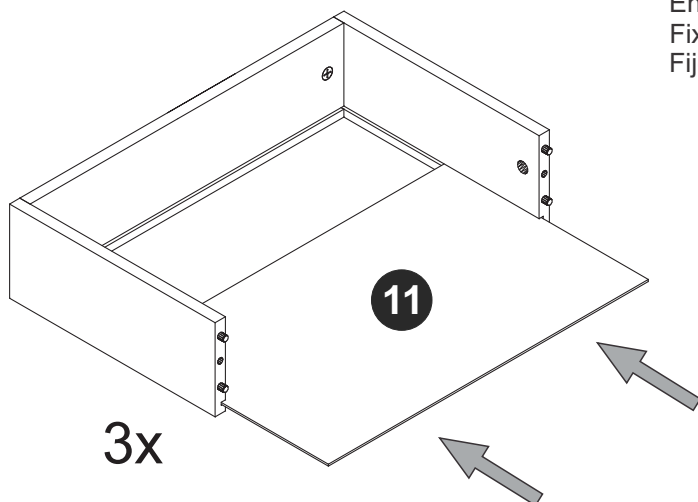

### PASSO 15 / STEP 15 / PASO 15

Conecte a peça 08, insira a ferragem EF 000216 e gire para apertar.  
Fixe o puxador utilizando a ferragem EF 000381.  
Connect piece 08, insert hardware EF 000216 and turn to tighten.  
Attach the handle using hardware EF 000381.  
Junte la pieza 08, añade el herraje EF 000216 y gire para apretar.  
Fije la manija utilizando el herraje EF 000381.

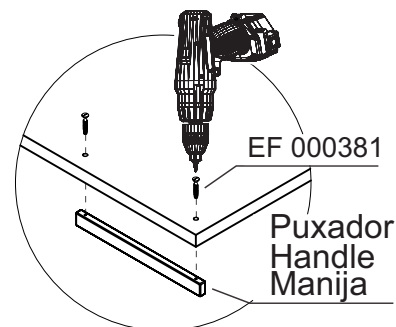
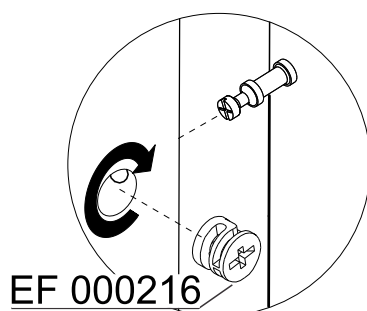
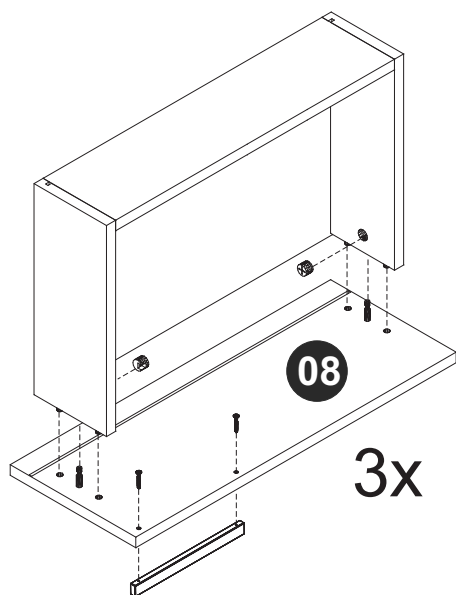

### PASSO 16 / STEP 16 / PASO 16

Fixe as corrediças utilizando a ferragem EF 000106.  
Attach the drawer tracks using hardware EF 000106.  
Fije las correderas utilizando el herraje EF 000106.

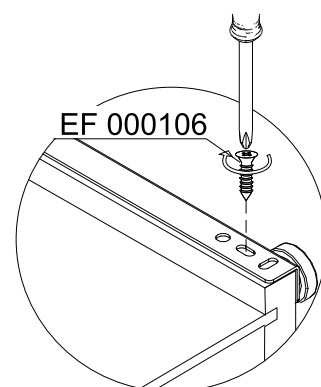
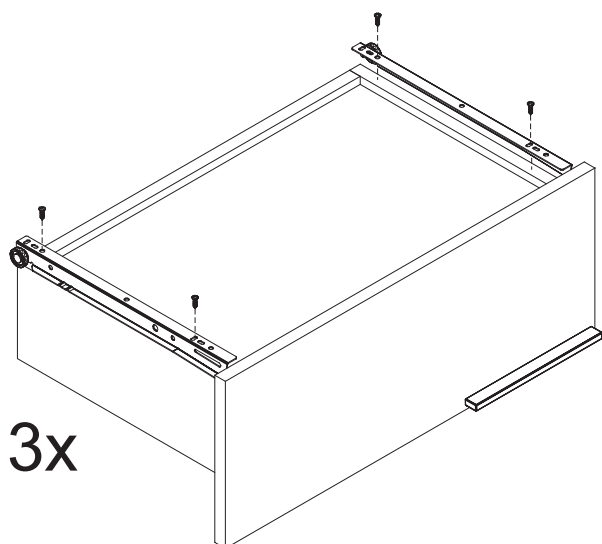

### PASSO 17 / STEP 17 / PASO 17

Fixe as peças 09 e 10 ao móvel montado.  
Fix pieces 09 and 10 to the assembled furniture.  
Fije las piezas 09 y 10 al mueble armado.

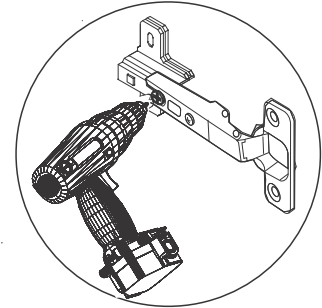
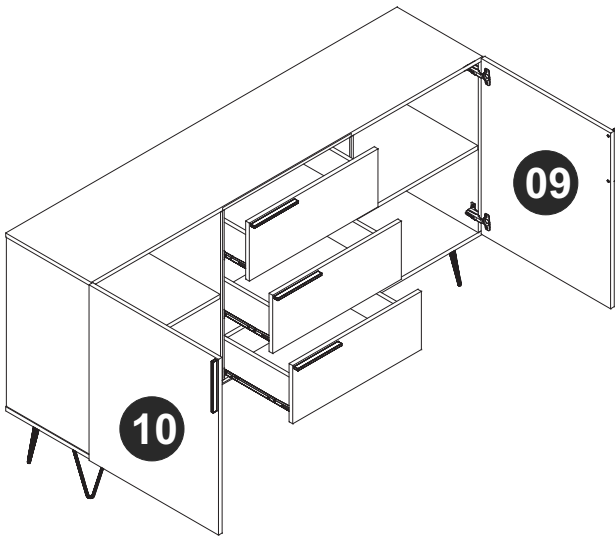

### PASSO 18 / STEP 18 / PASO 18

Utilize o tapa furos para cobrir os parafusos aparentes.  
Use the sticker to cover the apparent screws.  
Utilice los tapa huecos para cubrir los tornillos aparentes.

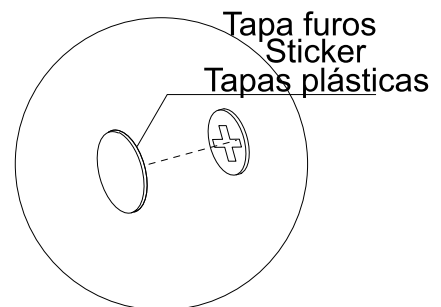
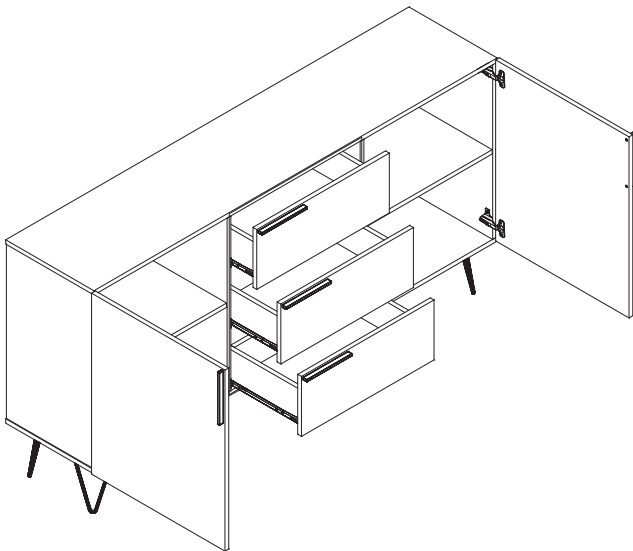

### PASSO 19 / STEP 19 / PASO 19

Utilize o giz para dar o acabamento final ao produto.  
Use the chalk to give the final finish on the product.  
Utilice la tiza para dar el acabado final al producto.

