



MANUAL DE MONTAGEM
ASSEMBLY INSTRUCTIONS
INSTRUCCIONES DE MONTAJE

COD BR: BA 51

Sumário Summary Resumen

Introdução Introduction Introducción	3
Antes de começar Before starting Antes de comenzar	4
Evite acidentes Avoid accidents Evitar accidentes	4
Dimensões e ferramentas Dimensions and tools Dimensiones y herramientas	5
Identificação das peças Identifying parts Identificación de las piezas	6
Acessórios incluídos na caixa Hardware included in box Accesorios incluidos en la caja	7
Montagem do móvel Furniture assembly Montaje del mueble	8

Introdução Introduction Introducción

Leia atentamente este manual e siga os passos indicados para que o produto não perca a garantia e também para uma perfeita montagem.

Read this manual and follow the steps in order to keep the guarantee and also for the perfect fit.

Lea este manual y siga los pasos para que el producto no pierda la garantía y también para el ajuste perfecto.

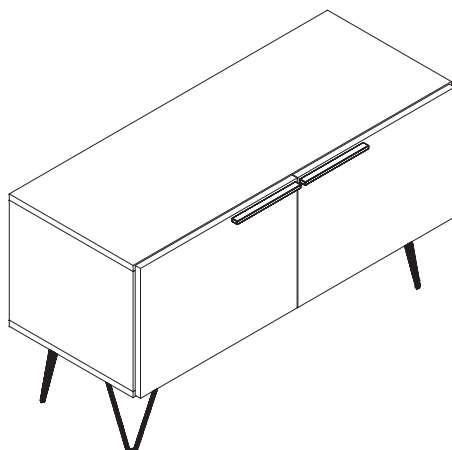

Antes de começar Before starting Antes de comenzar

Antes de começar a montagem prepare o ambiente, deixando-o completamente limpo e com bom espaço para iniciar o trabalho.

Prepare the room before starting the assembly, leaving it completely clean and the area in good condition to start the work.

Antes de comenzar el montaje preparar el ambiente, dejándolo completamente limpio y con bueno espacio para comenzar el trabajo.

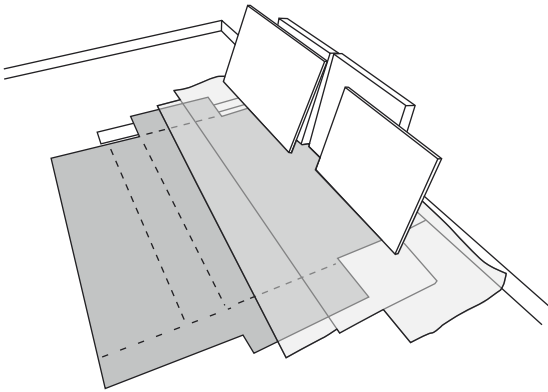

Utilize o papelão da própria embalagem para separar e apoiar as peças retiradas das caixas.

Use the cardboard of the packaging to separate and support the parts removed from the boxes.

Utilice el cartón de la embalaje para separar y apoyar las piezas desmontadas de las cajas.

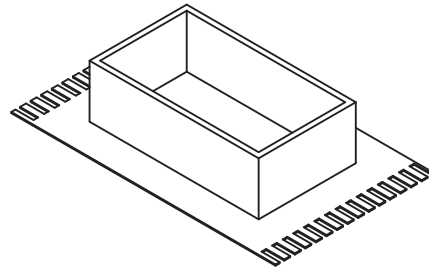

Forre a área de montagem com um cobertor ou tapete. Assim, você evita avarias nas peças durante o processo de montagem.

Cover the assembly area with a blanket or carpet to avoid damaging the parts during the assembly process.

Cubrir la zona de ensamble con una manta o alfombra. De este modo, se evitan daños en las piezas durante el proceso de montaje.



Evite acidentes Avoid accidents Prevenir accidentes

Solicitamos observar atentamente as orientações de montagem como: fixação do produto na parede, colocação de cola em locais específicos necessários, o peso suportado pelo produto, etc...

We request you to carefully observe the assembly instructions as: fixing the product on the wall, adding glue in needed and specific places, product weight limit, etc.

Pedimos que lea atentamente las instrucciones, principalmente las informaciones de fijación del producto en la pared, colocación de pegamento en local específico y necesario, el peso soportado por el producto etc...

Não escale ou se apoie no móvel.

Do not climb or lean on the furniture.

No se suba ni se apoye en el mueble.

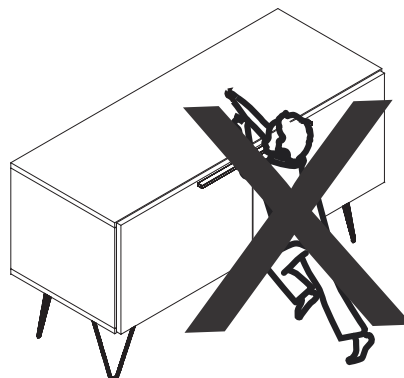

Dimensões e ferramentas
Dimensions and tools
Dimensiones y herramientas

Dimensões:

L: 900 A: 504 P: 365 mm

Dimensions:

W: 35.43 H: 19.84 D: 14.37 inches

Dimensiones:

L: 900 A: 504 P: 365 mm

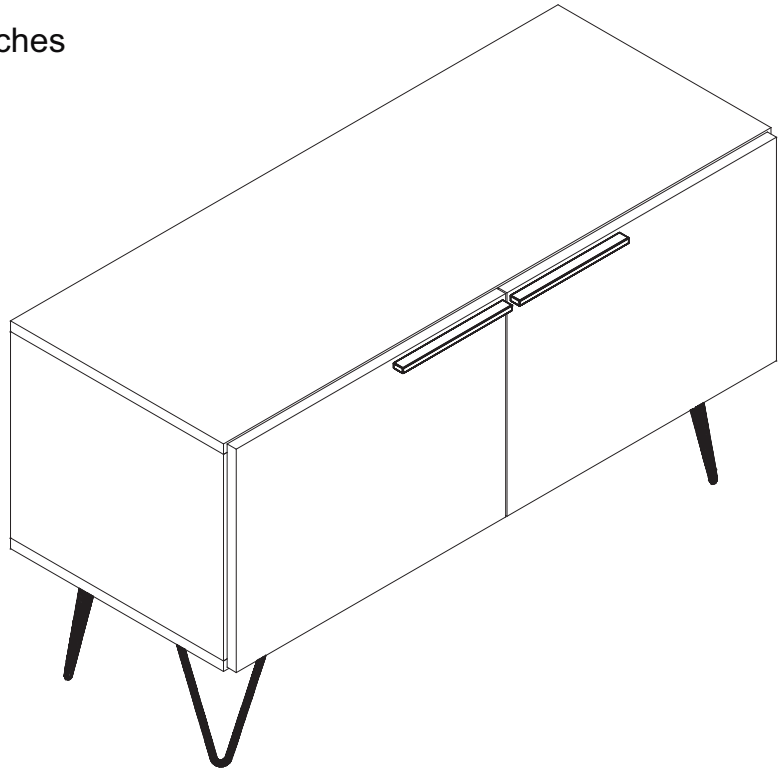

Limpeza
Cleaning
Limpieza



Pano levemente umedecido com água, seguido de pano seco, não utilizar produtos químico ou abrasivos.
Slightly dampened cloth and after a dry cloth, do not use chemicals or abrasives.
Solamente utilizar un paño húmedo y después un paño seco, no utilice productos químicos o abrasivos.

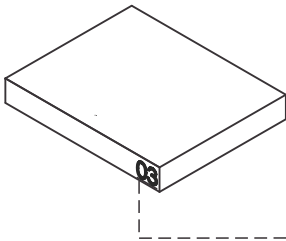

UTILIZE ALCOOL APENAS PARA REMOVER O NUMERO DAS PEÇAS
USE ALCOHOL ONLY TO REMOVE PART NUMBERS
UTILICE ALCOHOL SOLAMENTE PARA ELIMINAR EL NUMERO DE LAS PIEZAS

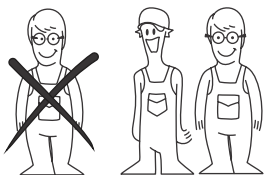

Para facilitar a montagem, utilize uma parafusadeira elétrica.
To improve assembly, use an electronic screwdriver.
Para facilitar el armado, utilice un destornillador eléctrico.

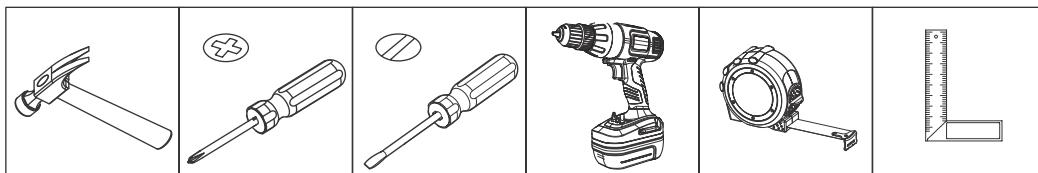

COD BR: BA 51

PEÇA	DESCRIÇÃO	QUANT.	PART	DESCRIPTION	QTY	PIEZA	DESCRIPCIÓN	CANTIDAD
001	BASE	1	001	BASE	1	001	BASE	1
002	TAMPO	1	002	TOP	1	002	TAPA	1
003	LATERAL ESQUERDA	1	003	LEFT SIDE	1	003	LATERAL IZQUIERDA	1
004	LATERAL DIREITA	1	004	RIGHT SIDE	1	004	LATERAL DERECHA	1
005	DIVISÓRIA	1	005	PARTITION	1	005	PARTICIÓN	1
006	PORTA ESQUERDA	1	006	LEFT DOOR	1	006	PUERTA IZQUIERDA	1
007	PORTA DIREITA	1	007	RIGHT DOOR	1	007	PUERTA DERECHA	1
008	COSTA	1	008	BACK	1	008	REVÉS	1
009	PÉS	4	009	FEET	4	009	PIES	4

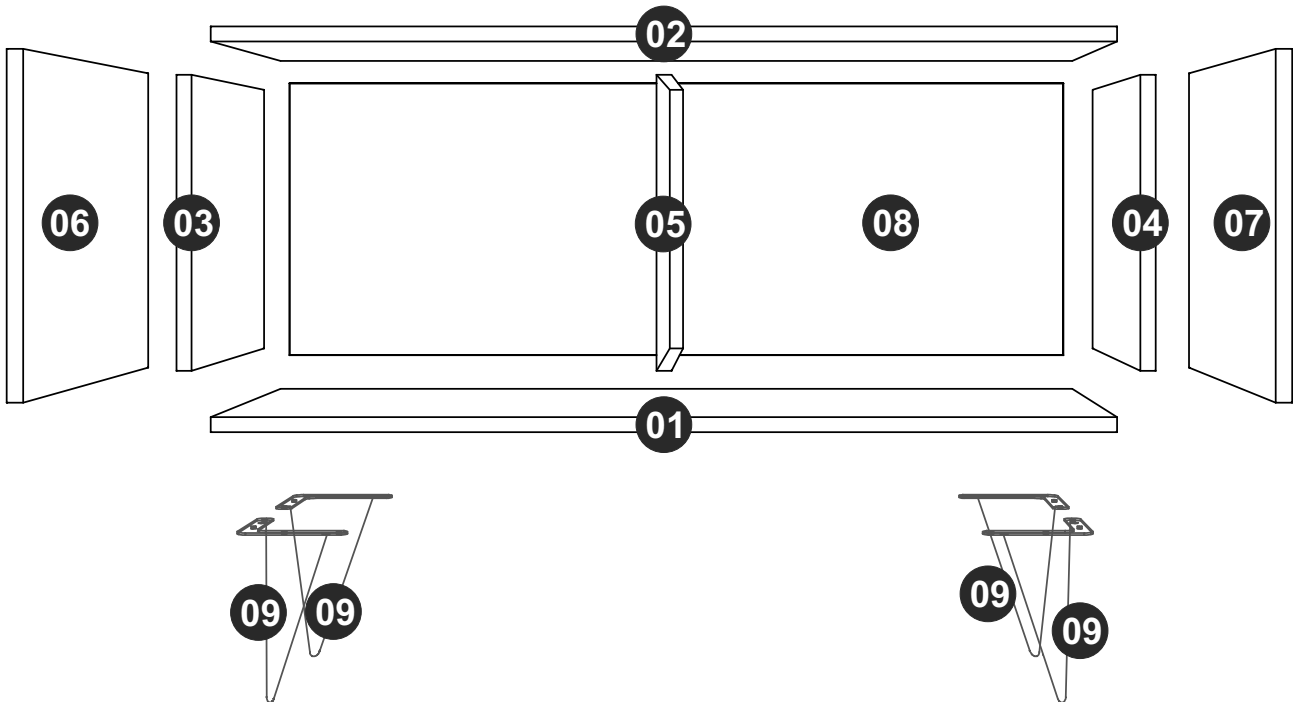

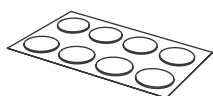

TAPA FUROS x 06
STICKER x 06
TAPAS PLÁSTICAS x 06



EF 000132 x 06
4X50 CC



EF 000106 x 24
3,5X14 CC



EF 000033 x 12
8x30



GIZ x 01
CHALK x 01
TIZA x 01



EF 000216 X 06



EF 000094 X 06



EF 000381 x 04
3x25 CC

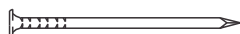

EF 000168 X 22
10x10 C/C

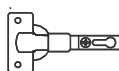

EF 000044 X 04



EF 000024 X 04



PUXADOR x 02
HANDLE x 02
MANIJA x 02

Utilize para medir as ferragens.

Utilice para medir el herraje.

Use for measuring the hardware.

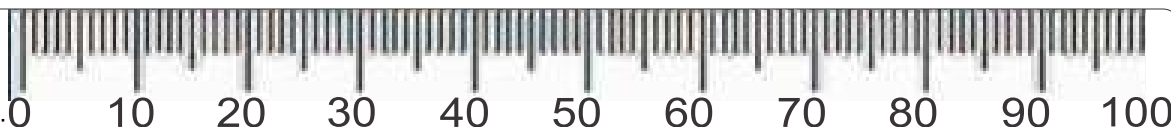

Garantia (exclusivo para o Brasil/exclusivo de Brasil/exclusive to Brazil):

A garantia dos produtos fabricados pela BRV Móveis, abrange eventuais defeitos-vícios de fabricação, no prazo estabelecido pelo código de Defesa do Consumidor, em seu artigo 26.II. o qual prevê a garantia de 90 (noventa) dias.

A = 11KG - 24.25LB

B = 5KG - 11.02LB

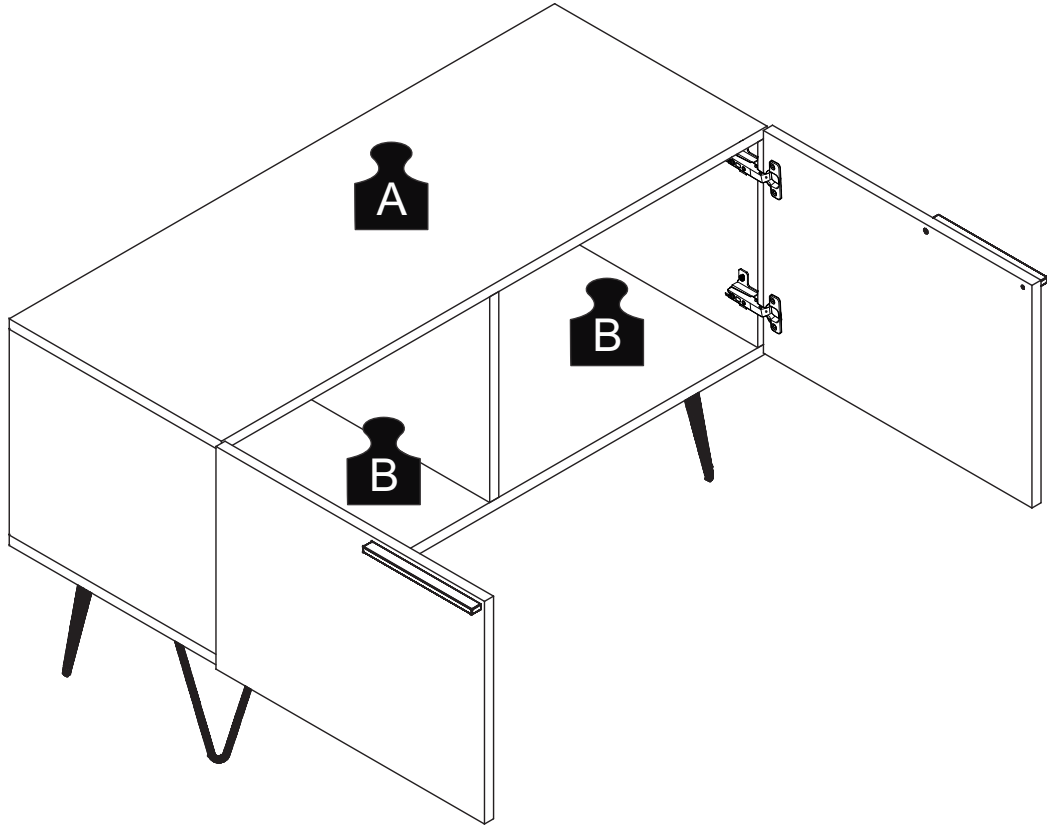

PASSO 1 / STEP 1 / PASO 1

Fixe a ferragem EF 000094 na peça 02.
Fix hardware EF 000094 in piece 02.
Fije el herraje EF 000094 en la pieza 02.

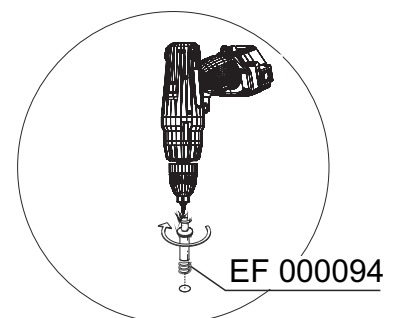
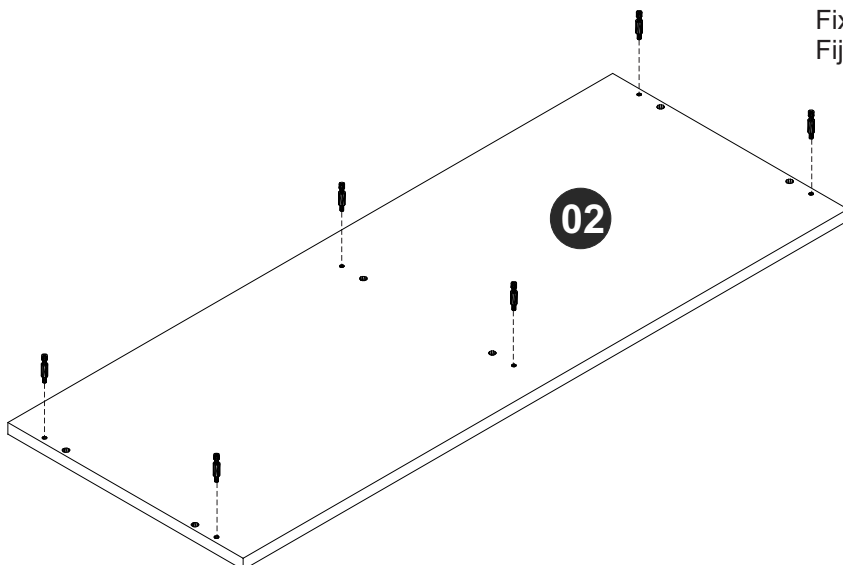

PASSO 2 / STEP 2 / PASO 2

Insira a ferragem EF 000033 nas peças 03, 04 e 05.
Insert hardware EF 000033 into pieces 03, 04 and 05.
Añade el herraje EF 000033 en las piezas 03, 04 y 05.

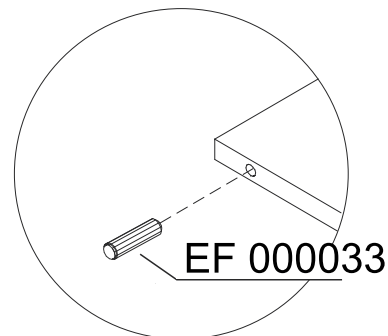
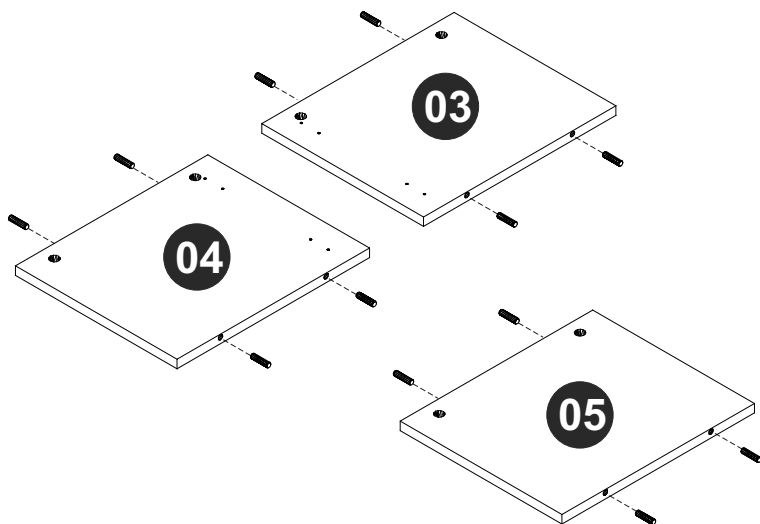

PASSO 3 / STEP 3 / PASO 3

Fixe a ferragem EF 000024 nas peças 03 e 04 usando a ferragem EF 000106.
Fix hardware EF 000024 into pieces 03 and 04 using hardware EF 000106.
Fije el herraje EF 000024 en las piezas 03 y 04 utilizando el herraje EF 000106.

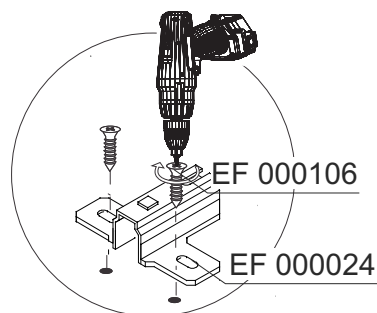
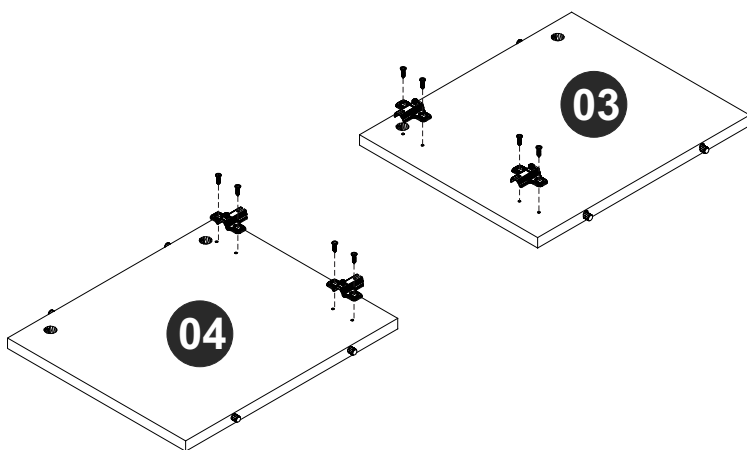

PASSO 4 / STEP 4 / PASO 4

Fixe o puxador usando a ferragem EF 000381. Fixe a ferragem EF 000044 usando a ferragem EF 000106.
Fix the handle using hardware EF 000381. Fix hardware EF 000044 using hardware EF 000106.
Fije la manija utilizando el herraje EF 000381. Fije el herraje EF 000044 utilizando el herraje EF 000106.

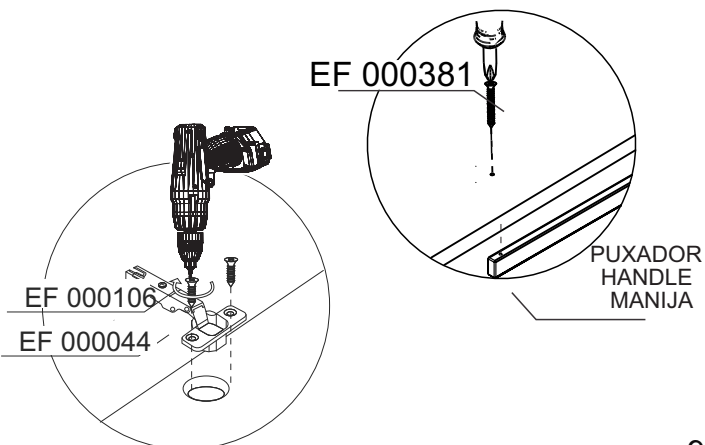
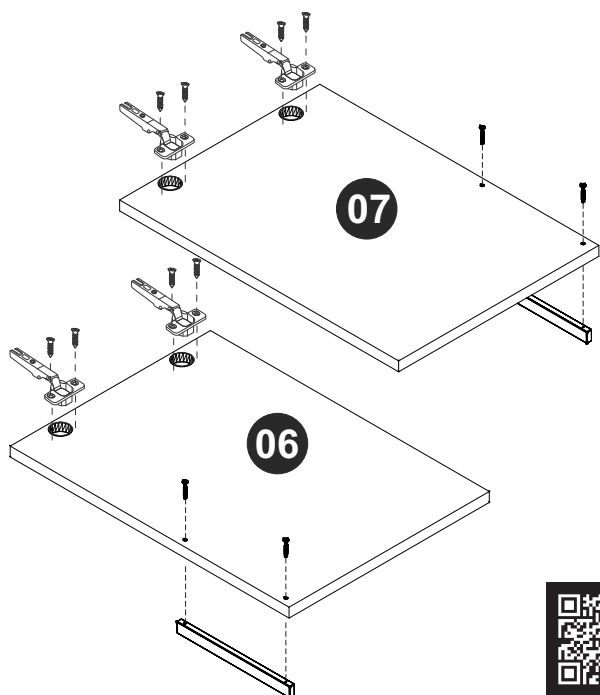

PASSO 5 / STEP 5 / PASO 5

Conecte as peças 02, 03 e 05, insira a ferragem EF 000216 e gire para apertar.
Connect pieces 02, 03 and 05, insert hardware EF 000216 and turn to tighten.
Junte las piezas 02, 03 y 05, añada el herraje EF 000216 y gire para apretar.

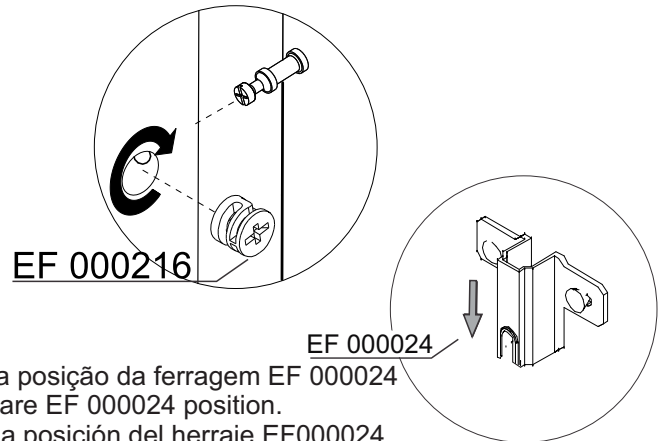
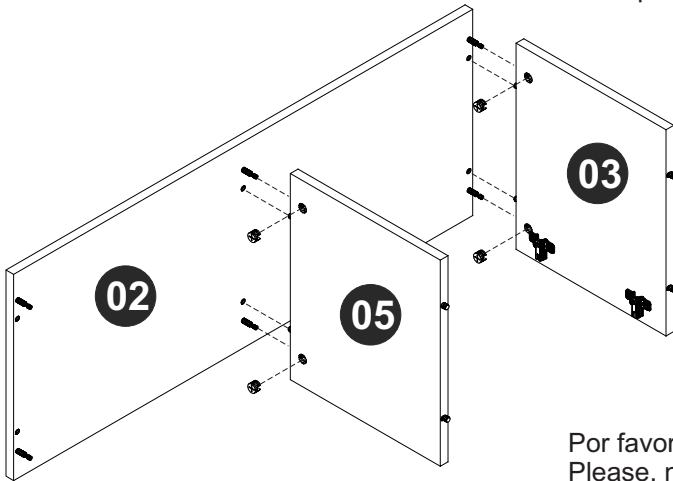

Por favor, observe a posição da ferragem EF 000024
Please, note hardware EF 000024 position.
Por favor, observe la posición del herraje EF000024.

PASSO 6 / STEP 6 / PASO 6

Conecte a peça 04, insira a ferragem EF 000216 e gire para apertar.
Connect piece 04, insert hardware EF 000216 and turn to tighten.
Junte la pieza 04, añada el herraje EF 000216 y gire para apretar.

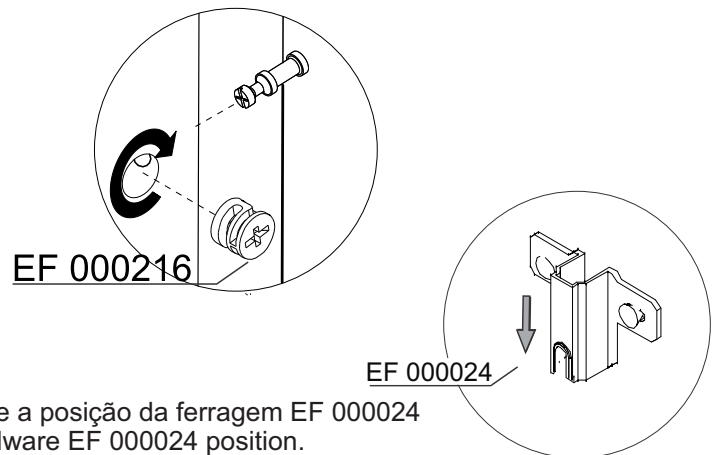
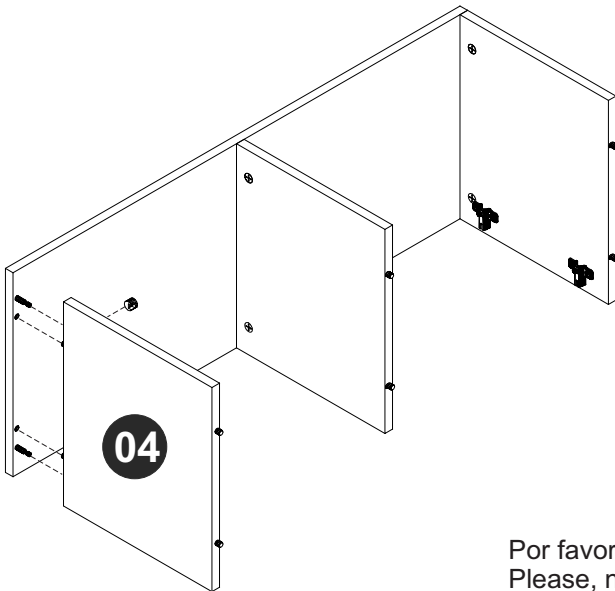

Por favor, observe a posição da ferragem EF 000024
Please, note hardware EF 000024 position.
Por favor, observe la posición del herraje EF000024.

PASSO 7 / STEP 7 / PASO 7

Conecte os pés à peça 01 utilizando a ferragem EF 000106.
Connect the feet to piece 01 using hardware EF 000106.
Junte los pies a la pieza 01 utilizando el herraje EF 000106.

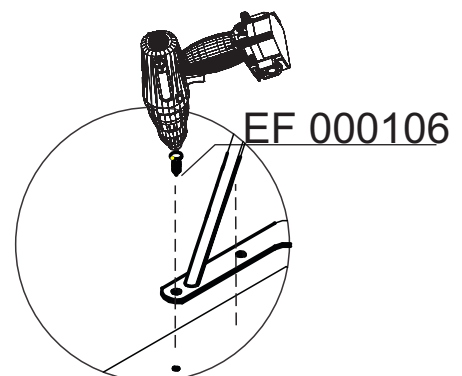
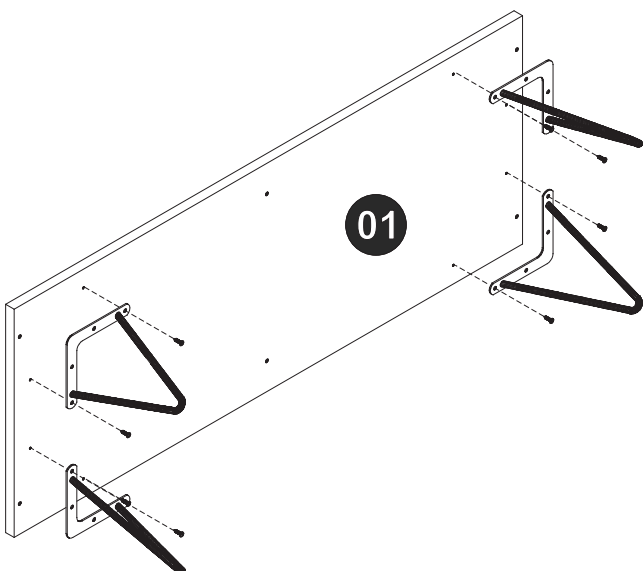

PASSO 8 / STEP 8 / PASO 8

Fixe a peça 01 utilizando a ferragem EF 000132.
Attach piece 01 using hardware EF 000132.
Fije la pieza 01 utilizando el herraje EF 000132.

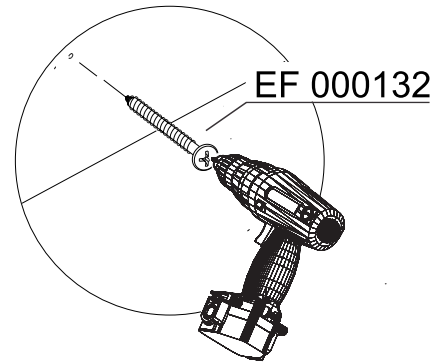
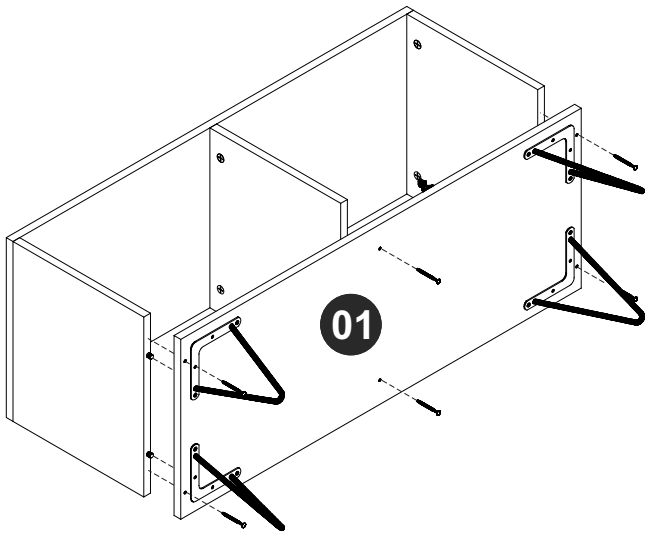

PASSO 9 / STEP 9 / PASO 9

Fixe a peça 08 ao móvel utilizando a ferragem EF 000168.
Fix piece 08 at the furniture using hardware EF 000168.
Fije la pieza 08 al mueble utilizando el herraje EF 000168.

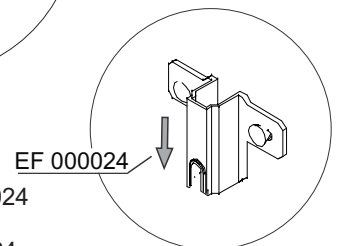
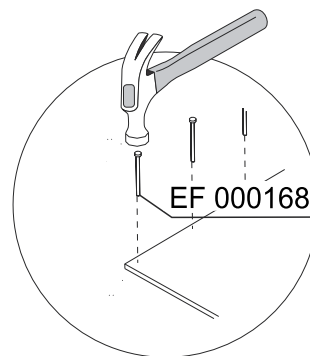
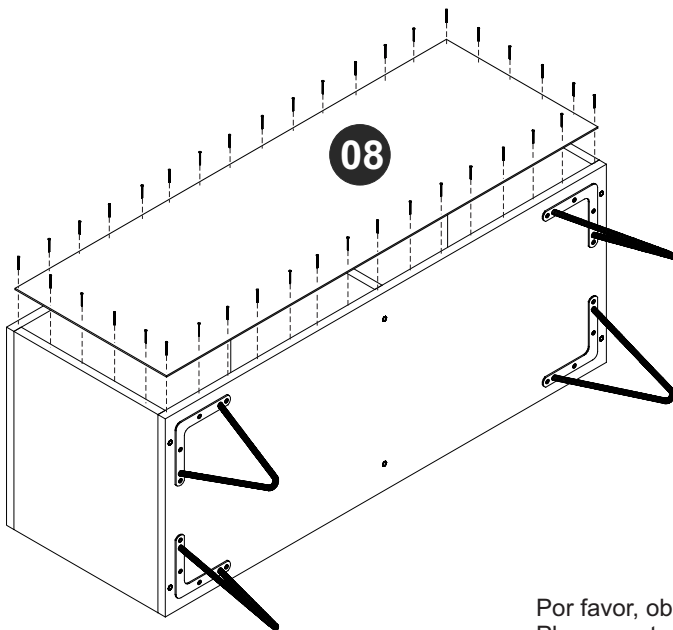

Por favor, observe a posição da ferragem EF 000024
Please, note hardware EF 000024 position.
Por favor, observe la posición del herraje EF000024.

PASSO 10 / STEP 10 / PASO 10

Fixe as peças 06 e 07 ao móvel montado.
Fix pieces 06 and 07 at the assembled furniture.
Fije las piezas 06 y 07 al mueble armado.

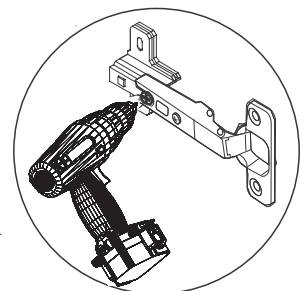
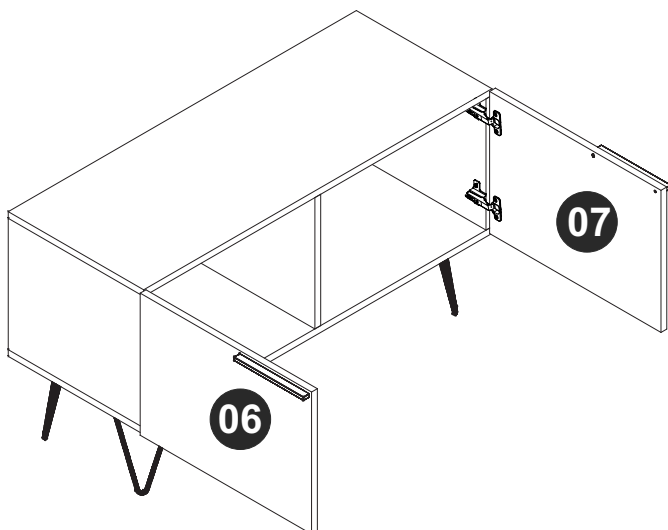

PASSO 11 / STEP 11 / PASO 11

Use os tapa furos para cobrir os parafusos aparentes.
Use stickers to cover apparent screws.
Utilice los tapa huecos para cubrir los tornillos aparentes.

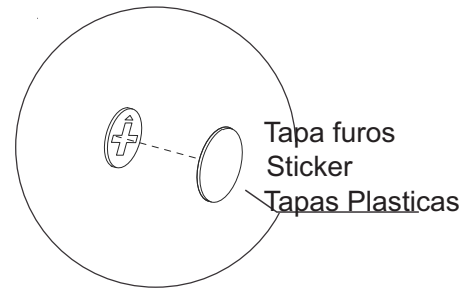
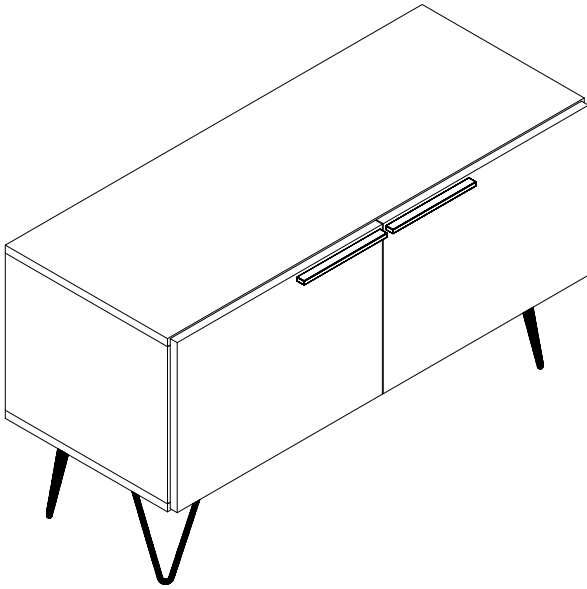

PASSO 12 / STEP 12 / PASO 12

Use o giz para dar o acabamento final ao produto.
Use the chalk to give the final finish on the product.
Utilice la tiza para dar el acabado final al producto.

