

# **HOMMY 05-W**

# **HOMMY 05-B**



**MANUAL DE MONTAGEM**  
***ASSEMBLY INSTRUCTIONS***  
***INSTRUCCIONES DE MONTAJE***



Introdução..... 3 <i>Introduction</i> <i>Introducción</i>	Identificação das peças..... 6 <i>Identifying parts</i> <i>Identificación de las piezas</i>
Evite acidentes..... 3 <i>Avoid accidents</i> <i>Evitar accidentes</i>	Acessórios incluídos na caixa..... 7 <i>Hardware included in box</i> <i>Accesorios incluidos en la caja</i>
Antes de começar..... 4 <i>Before Starting</i> <i>Antes de comenzar</i>	Capacidade..... 8 <i>Weight Capacity</i> <i>Peso Soportado</i>
Dimensões e ferramentas..... 5 <i>Dimensions and tools</i> <i>Dimensiones y herramientas</i>	Montagem do móvel..... 8 <i>Furniture assembly</i> <i>Montaje del mueble</i>

**Introdução / Introduction / Introducción**

Leia atentamente este manual e siga os passos indicados para que o produto não perca a garantia e também para uma perfeita montagem.

*Read this manual and follow the steps in order to keep the guarantee and also for the perfect fit.*

*Lea este manual y siga los pasos para que el producto no pierda la garantía y también para el ajuste perfecto.*

**Evite acidentes / Avoid accidents / Prevenir accidentes**

Solicitamos observar atentamente as orientações de montagem como: fixação do produto na parede, colocação de cola em locais específicos necessários, o peso suportado pelo produto, etc...

*We request you to carefully observe the assembly instructions as: fixing the product on the wall, adding glue in needed and specific places, product weight limit, etc.*

*Pedimos que lea atentamente las instrucciones, principalmente las informaciones de fijación del producto en la pared, colocación de pegamento en local específico y necesario, el peso soportado por el producto etc...*



**Não escale ou se apoie no móvel.**  
*Do not climb or lean on the furniture.*  
*No se suba ni se apoye en el mueble.*

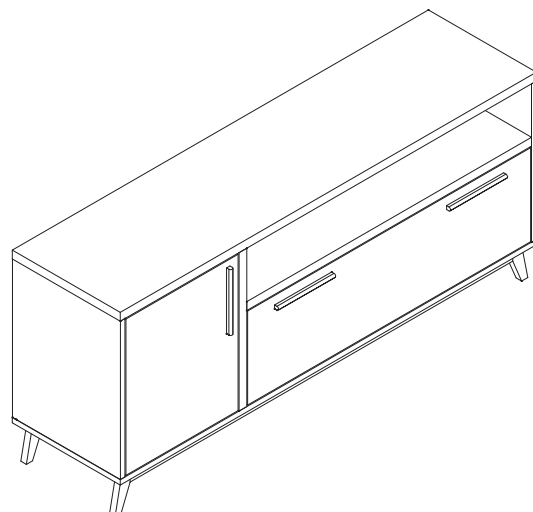

## Antes de começar / Before starting / Antes de comenzar

Antes de começar a montagem prepare o ambiente, deixando-o completamente limpo e com bom espaço para iniciar o trabalho.

*Prepare the room before starting the assembly, leaving it completely clean and the area in good condition to start the work.*

*Antes de comenzar el montaje preparar el ambiente, dejándolo completamente limpio y con bueno espacio para comenzar el trabajo.*

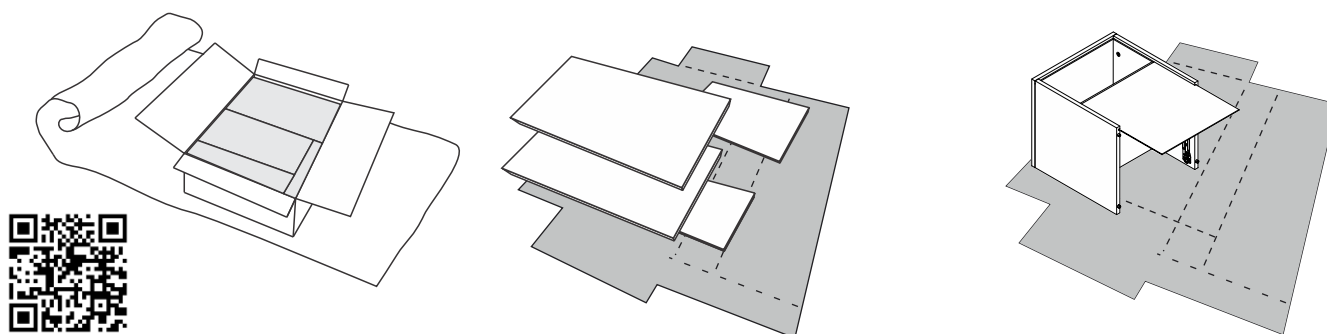

Utilize o papelão da própria embalagem para separar e apoiar as peças retiradas das caixas.

*Use the cardboard of the packaging to separate and support the parts removed from the boxes.*

*Utilice el cartón de la embalaje para separar y apoyar las piezas desmontadas de las cajas.*

Forre a área de montagem com um cobertor ou tapete. Assim, você evita avarias nas peças durante o processo de montagem.

*Cover the assembly area with a blanket or carpet to avoid damaging the parts during the assembly process.*

*Cubrir la zona de ensamble con una manta o alfombra. De este modo, se evitan daños en las piezas durante el proceso de montaje.*

## Limpeza / Cleaning / Limpieza

Pano levemente umedecido com água, seguido de pano seco, não utilizar produtos químicos ou abrasivos.

*Slight dampened cloth and after a dry cloth, do not use chemicals or abrasives.*

*Solamente utilizar un paño húmedo y después un paño seco, no utilice productos químicos o abrasivos.*

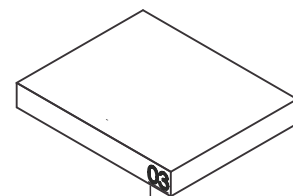

**UTILIZE ALCOOL APENAS PARA REMOVER O NUMERO DAS PEÇAS APÓS A MONTAGEM**  
**USE ALCOHOL ONLY TO REMOVE PART NUMBERS AFTER ASSEMBLY**

**UTILICE ALCOHOL SOLAMENTE PARA ELIMINAR EL NUMERO DE LAS PIEZAS DESPUÉS DEL MONTAJE**

**Dimensões e ferramentas / Dimensiones ardois / Dimensiones y herramientas**

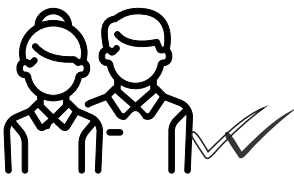
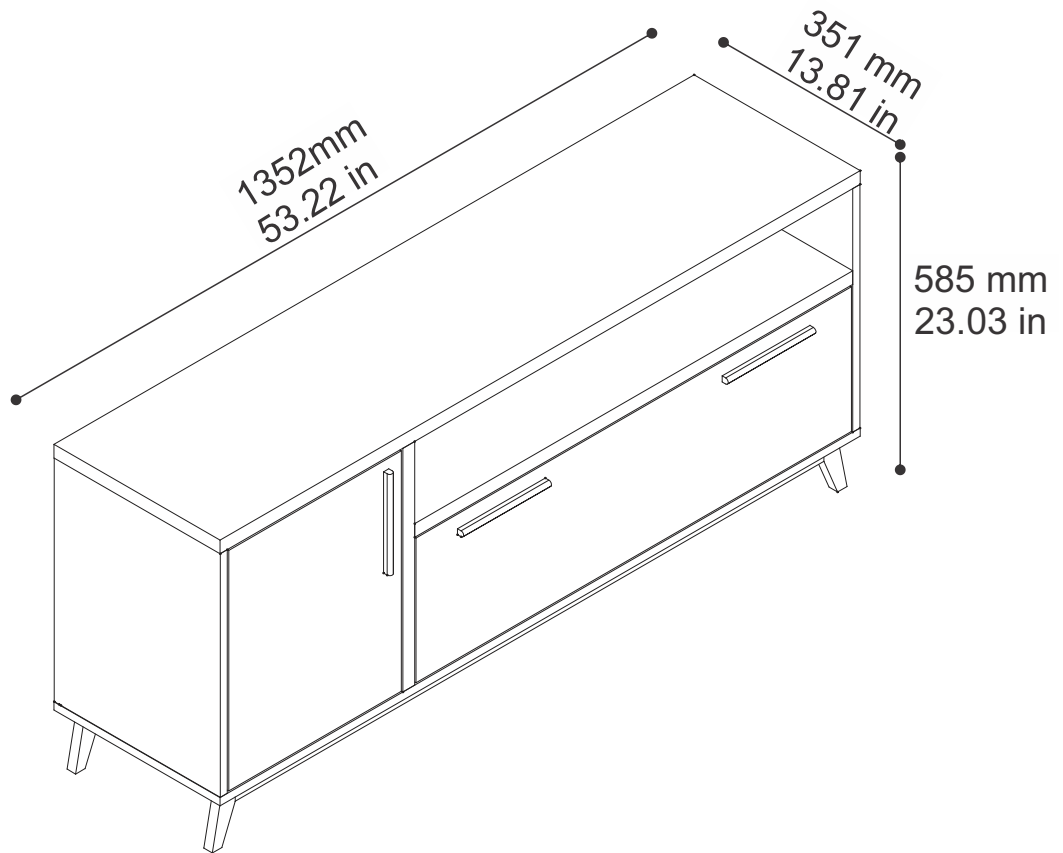

Será necessário auxílio para facilitar a montagem.  
*You may need help to assembly easier.*  
Se necesitará ayuda para facilitar el armado.

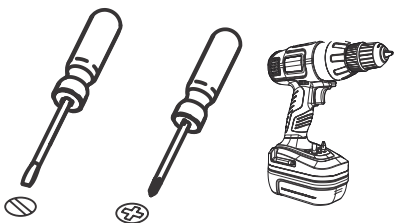

Para facilitar a montagem, utilize uma parafusadeira elétrica.  
To improve assembly, use an electronic screwdriver.  
Para facilitar el armado, utilice un destornillador eléctrico.

## Identificação das peças / Identifying parts / identificación de las piezas

PEÇA	DESCRIÇÃO	QUANT.	PART	DESCRIPTION	QTY	PIEZA	DESCRIPCIÓN	CANTIDAD
001	BASE	1	001	BASE	1	001	BASE	1
002	TAMPO	1	002	TOP	1	002	TAPA	1
003	LATERAL ESQUERDA	1	003	LEFT SIDE	1	003	LATERAL IZQUIERDA	1
004	LATERAL DIREITA	1	004	RIGHT SIDE	1	004	LATERAL DERECHA	1
005	PRATELEIRA	1	005	SHELF	1	005	REPISA	1
006	DIVISÓRIA MAIOR	1	006	LONGER PARTITION	1	006	PARTICIÓN MAYOR	1
007	PORTA MAIOR	1	007	LONGER DOOR	1	007	PUERTA MAYOR	1
008	PORTA MENOR	1	008	LOWER DOOR	1	008	PUERTA MENOR	1
009	DIVISÓRIA MENOR	1	009	LOWER PARTITION	1	009	PARTICIÓN MENOR	1
010	COSTA COM FURO	1	010	BACK WITH HOLE	1	010	REVÉS CON AGUJERO	1
011	COSTA MAIOR	1	011	LONGER BACK	1	011	REVÉS MAYOR	1
012	COSTA MENOR	1	012	LOWER BACK	1	012	REVÉS MENOR	1
013	PÉS	2	013	FEET	2	013	PIES	2

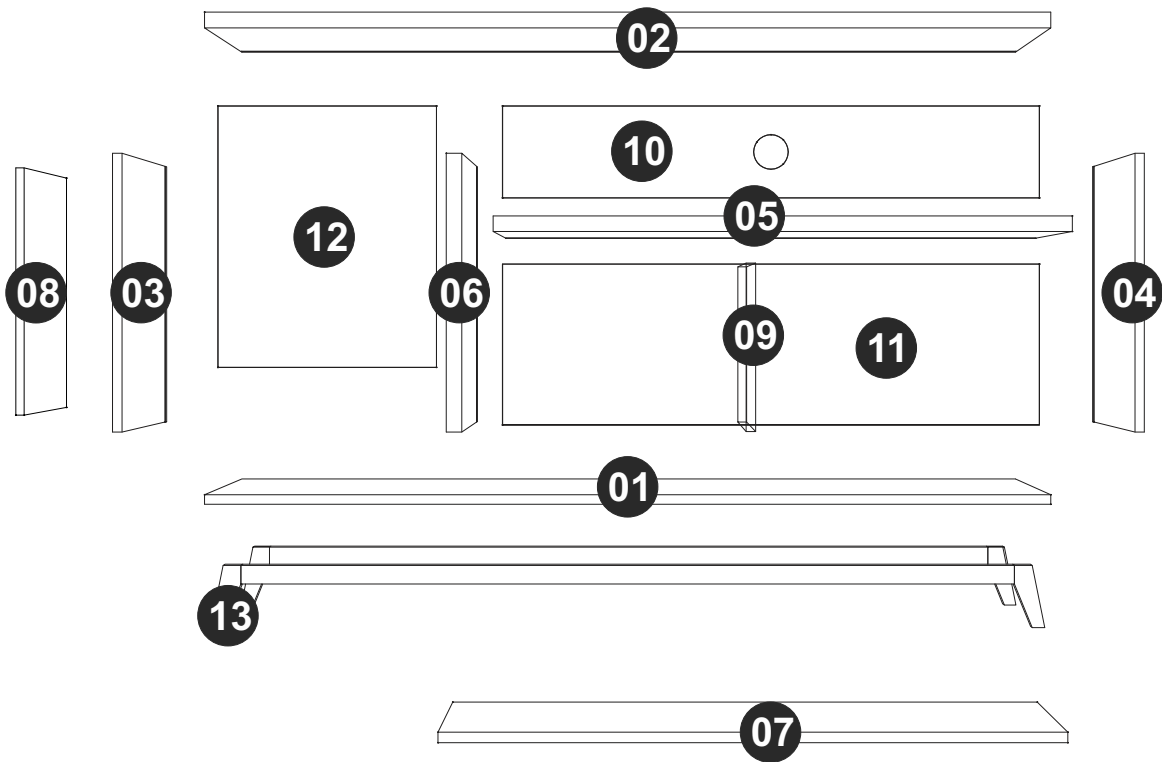

**Acessórios incluídos na caixa** *Hardware included in box* / *acessorios incluídos en laja*

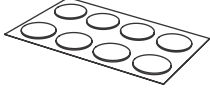

TAPA FUROS x 16  
STICKER x 16  
TAPAS PLÁSTICAS x 16

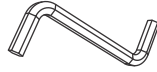

EF 000741 x 1



EF 000106 x 26



EF 000745 x 4



EF 000132 x 8

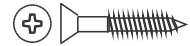

EF 000381 x 6

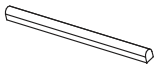

PUXADOR x 3  
HANDLE x 3  
MANIJA x 3



EF 000216 X 12



EF 000094 X 12

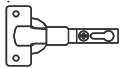

EF 000043 X 4

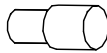

SUPORTE PLÁSTICO x 1  
PLÁSTIC SUPPORT x 1  
SOPORTE PLASTICOS x 1

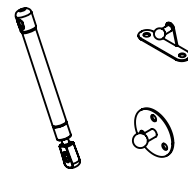

KIT AMORTECEDOR A GAS x 2  
LIFT SUPPORT KIT x 2  
AMORTIGUADOR A GAS x 2



EF 000033 x 20



GIZ x 01  
CHALK x 01  
TIZA x 01



EF 000025 X 4

## Capacidade/ Weight Capacity / Peso Soportado



19KG - 41.88LB



12KG - 26.45LB



5KG - 11.02LB

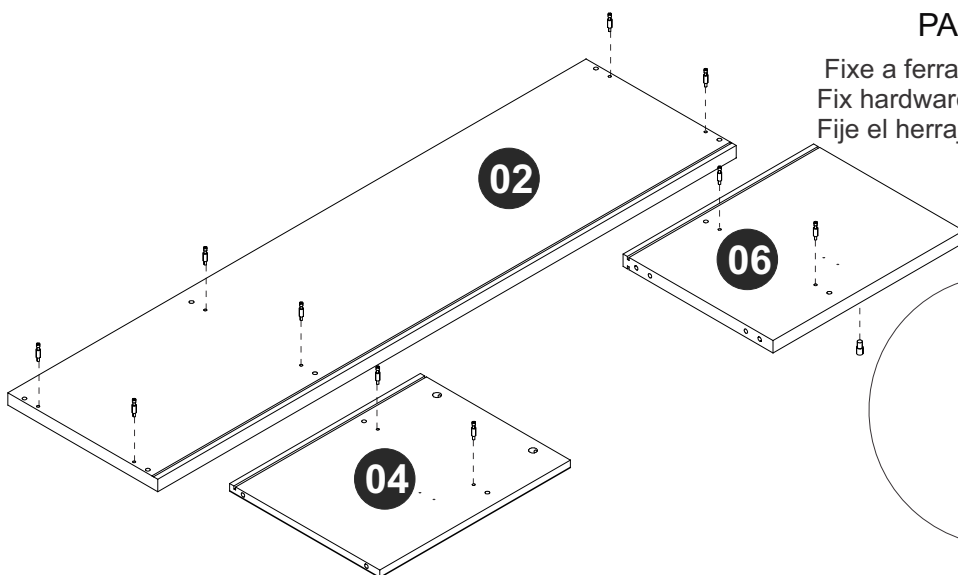
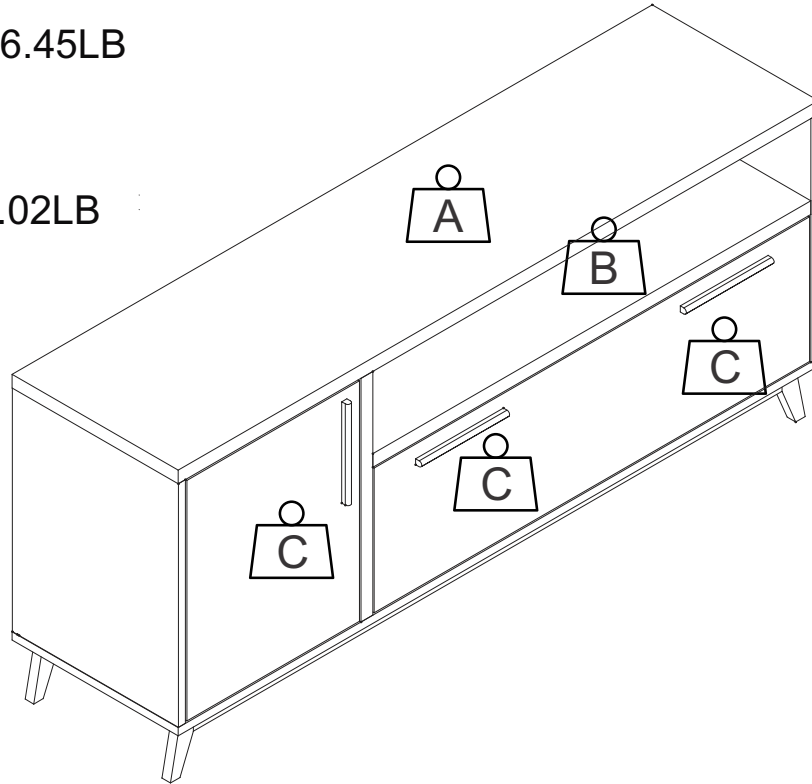

### PASSO 1 / STEP 1 / PASO 1

Fixe a ferragem EF 000094 nas peças 02, 04, e 06.  
Fix hardware EF 000094 in pieces 02, 04, and 06.  
Fije el herraje EF 000094 en las piezas 02, 04, y 06.

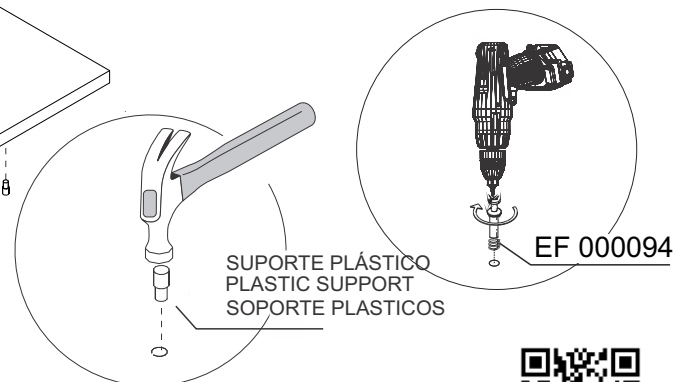

Insira o suporte plástico na peça 06.  
Insert the plastic support into piece 06.  
Añade el soporte plástico en la pieza 06.





## PASSO 2 / STEP 2 / PASO 2

Fixe a ferragem EF 000025 nas peças 01 e 03 utilizando a ferragem EF 000106.  
Attach hardware EF 000025 at pieces 01 and 03 using hardware EF 000106.  
Fije el herraje EF 000025 en las piezas 01 y 03 utilizando el herraje EF 000106.

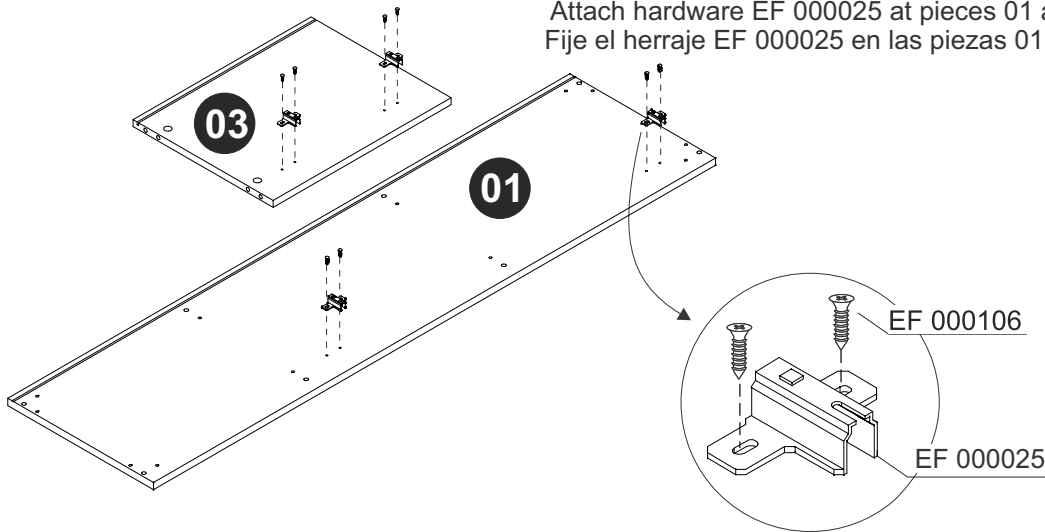

## PASSO 3 / STEP 3 / PASO 3

Fixe a ferragem EF 000043 na peça 07 utilizando a ferragem EF 000106.  
Fixe o puxador usando a ferragem EF 000381.  
Attach hardware EF 000043 on piece 07 using hardware EF 000106. Attach the handle using hardware EF 000381.  
Fije el herraje EF 000043 en las piezas 07 utilizando el herraje EF 000106.  
Fije la manija utilizando el herraje EF 000381.

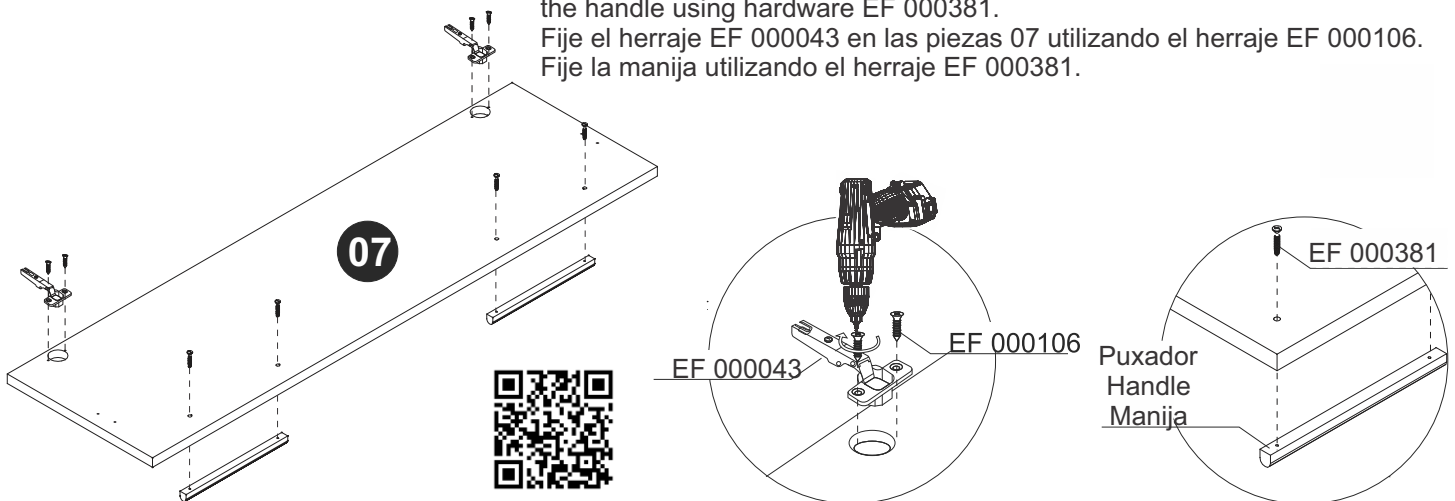

## PASSO 4 / STEP 4 / PASO 4

Insira a ferragem EF 000033 nas peças 03, 05 e 09.  
Insert hardware EF 000033 into pieces 03, 05 and 09.  
Añade el herraje EF 000033 en las piezas 03, 05 y 09.

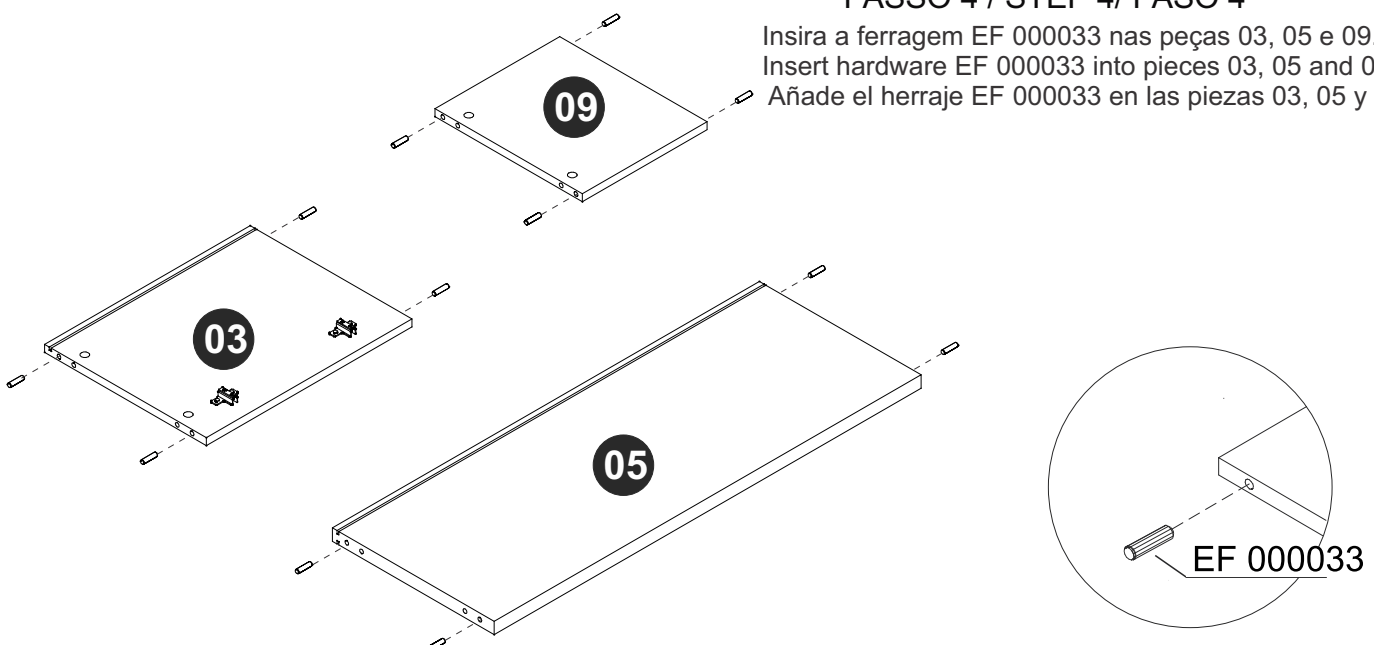

### PASSO 5 / STEP 5 / PASO 5

Fixe as peças 13 à peça 01 utilizando a ferragem EF 000745 e EF 000741.  
Fix pieces 13 to piece 01 using hardware EF 000745 and EF 000741.  
Junte las piezas 01 y 13 utilizando los herrajes EF 000745 y EF 000741.

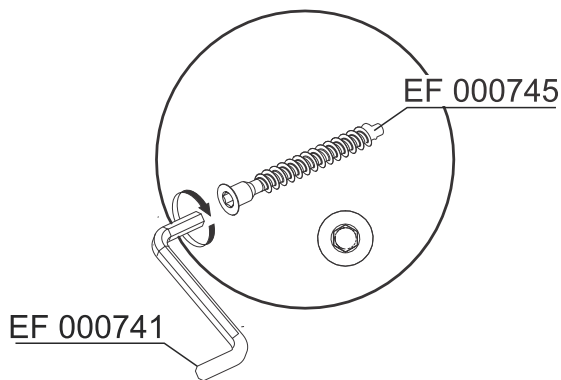
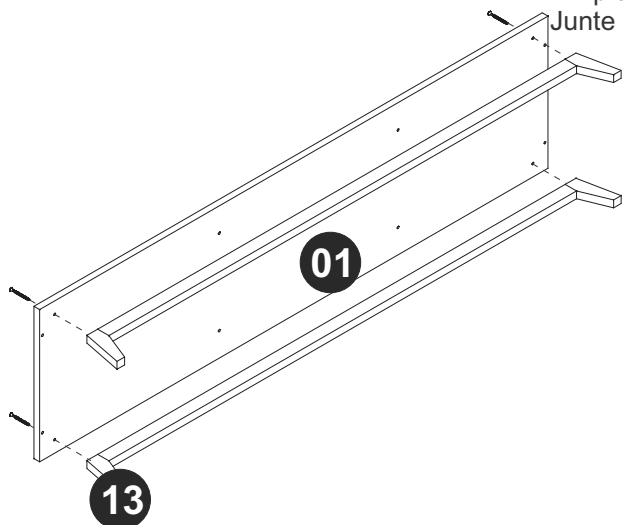

### PASSO 6 / STEP 6 / PASO 6

Conecte as peças 05 e 09, insira a ferragem EF 000216 e gire para apertar.  
Connect pieces 05 and 09, insert hardware EF 000216 and turn to tighten.  
Junte las piezas 05 y 09, añada el herraje EF 000216 y gire para apretar.

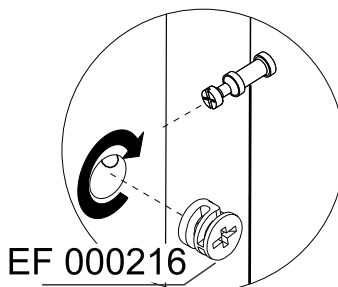
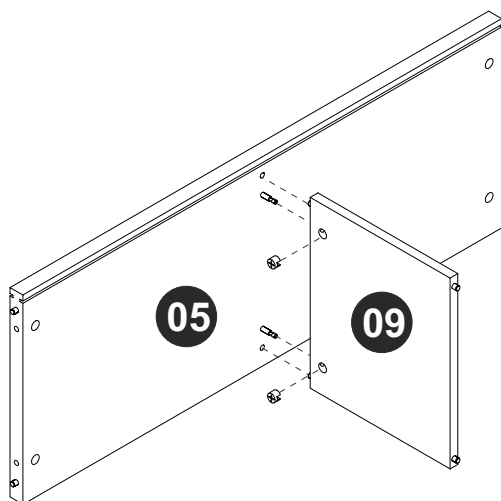

### PASSO 7 / STEP 7 / PASO 7

Conecte a parte montada no passo anterior e as peças 04 e 06, insira a ferragem EF 000216 e gire para apertar.  
Connect the part assembled in the previous step and pieces 04 and 06 insert hardware EF 000216 and turn to tighten.  
Junte la parte armada en el paso anterior y las piezas 04 y 06 añada el herraje EF 000216 y gire para apretar.

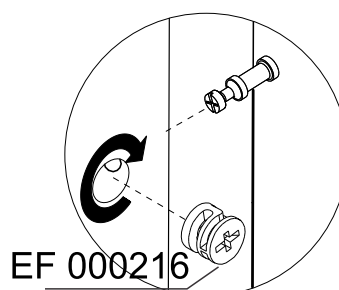
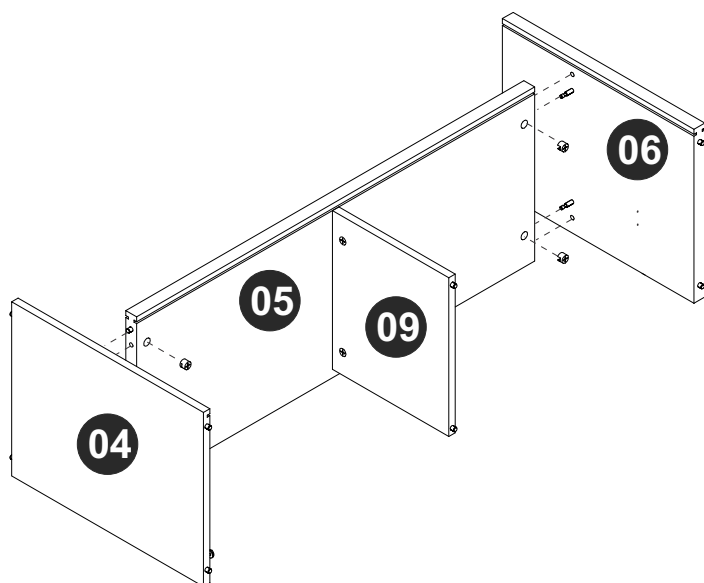

### PASSO 8 / STEP 8 / PASO 8

Encaixe as peças 10 e 11 entre os espaços específico nas peças 04 e 06.  
Fit pieces 10 and 11 in the specific spaces in pieces 04 and 06.  
Fije las piezas 10 y 11 entre los espacios específicos en las piezas 04 y 06.

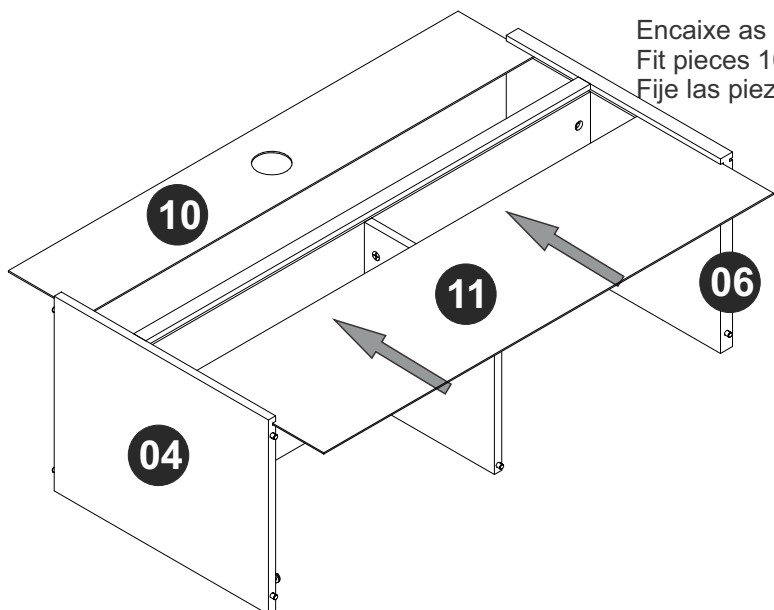

### PASSO 9 / STEP 9 / PASO 9

Encaixe as peças 03 e 12, fixe a peça 01 à parte montada no passo anterior utilizando a ferragem EF 000132.  
Fit pieces 03 and 12, attach piece 01 to the part assembled in the previous step using hardware EF 000132.  
Junte las piezas 03 y 12, fije la pieza 01 a la parte armado en el paso anterior utilizando el herraje EF 000132.

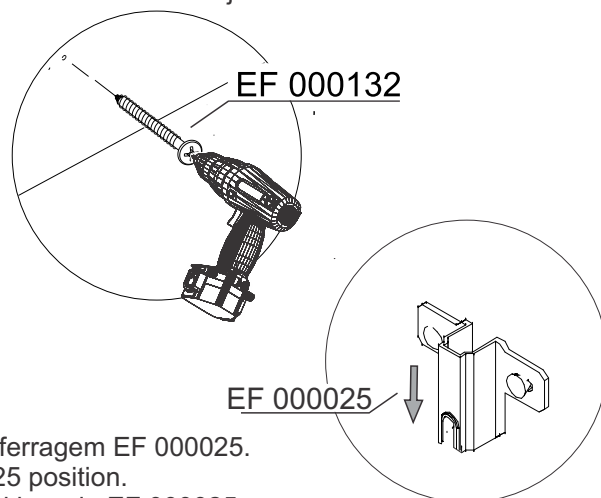
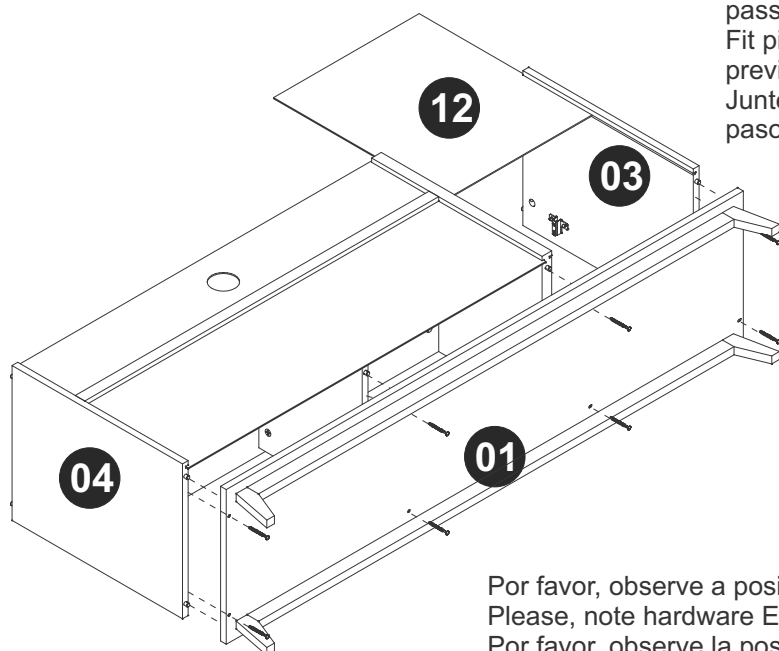

Por favor, observe a posição da ferragem EF 000025.  
Please, note hardware EF 000025 position.  
Por favor, observe la posición del herraje EF 000025.

### PASSO 10 / STEP 10 / PASO 10

Gire o móvel para conectar a peça 02 à parte montada no passo anterior, insira a ferragem EF 000216 e gire para apertar.  
Turn the furniture to connect piece 02 to the part assembled in the previous step insert hardware EF 000216 and turn to tighten.  
Vire el mueble para juntar la pieza 02 a la parte armada en el paso anterior, añade el herraje EF 000216 y gire para apretar.

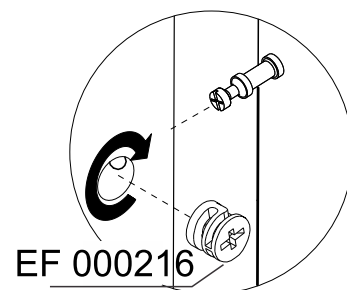
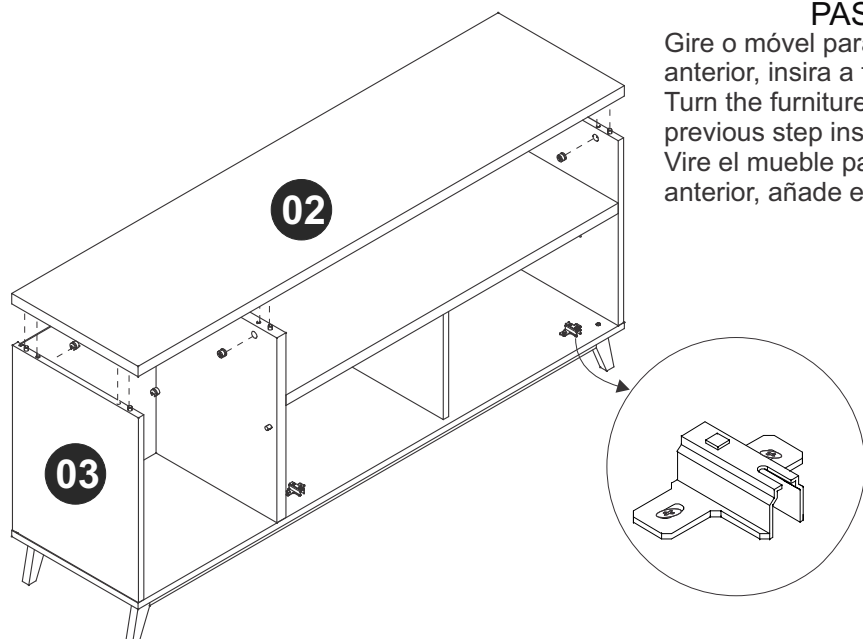

### PASSO 11 / STEP 11/ PASO 11

Fixe as peças 07 e 08 ao móvel montado,  
Attach pieces 07 and 08 to assembled furniture.  
Fije las piezas 07 y 08 al mueble armado.

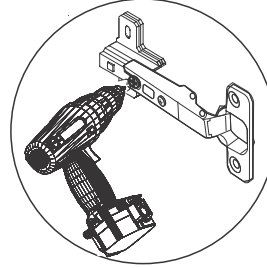
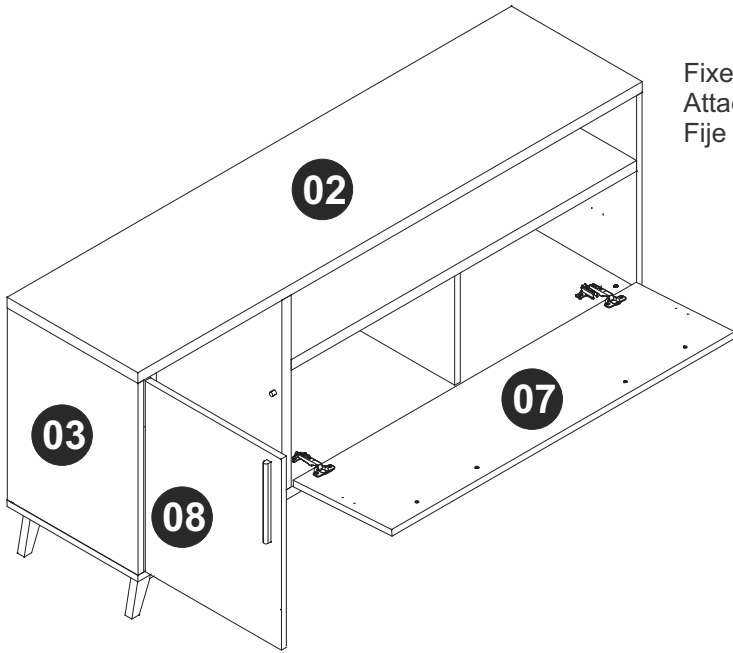

### PASSO 12 / STEP 12 / PASO 12

Fixe as partes 1 e 2 utilizando a ferragem EF 000106 de acordo com a  
imagem. Encaixe a parte 3.

Attach the parts 1 and 2 using hardware EF 000106, according to the image,  
then fit the part 3.

Fije las partes 1 y 2 utilizando el herraje EF 000106 de acuerdo con la  
imagen, junte la parte 3.

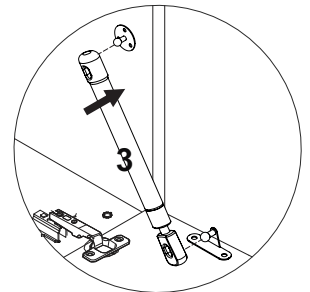
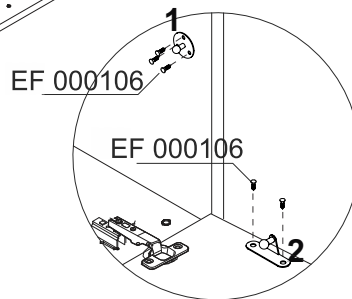
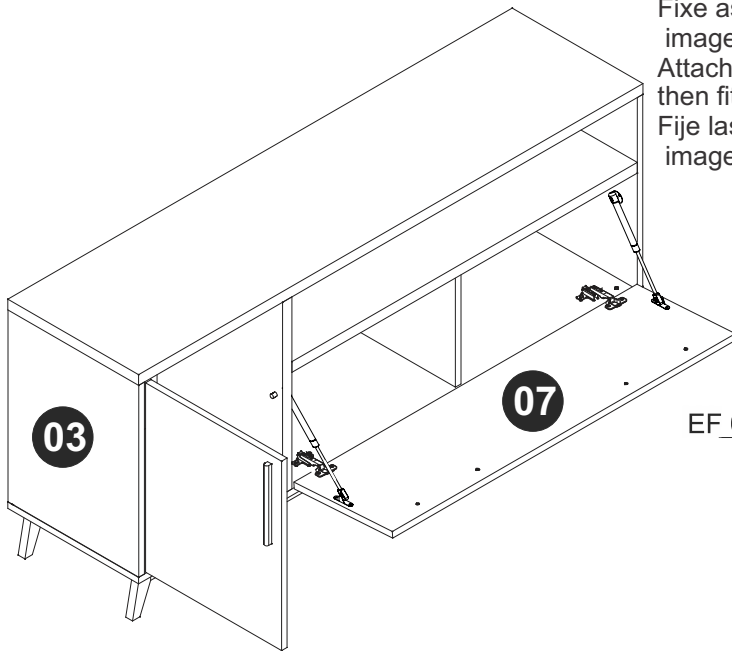

### PASSO 13 / STEP 13 / PASO 13

Use os tapa furos para cobrir os parafusos aparentes.

Use o giz para dar o acabamento final ao produto.

Use stickers to cover apparent screws.

Use the chalk to give the final finish on the product.

Utilice los tapa huecos para cubrir los tornillos aparentes.

Utilice la tiza para dar el acabado final al producto.

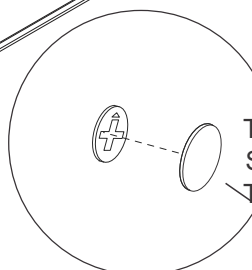
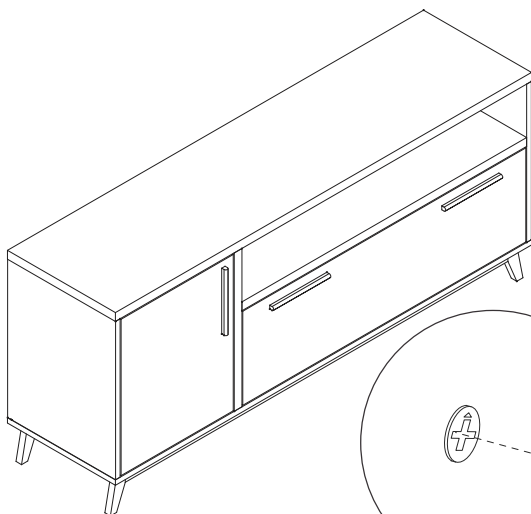

Tapa furos  
Sticker  
Tapas Plasticas

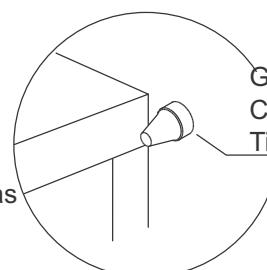

Giz  
Chalk  
Tiza

