



**MANUAL DE MONTAGEM
ASSEMBLY INSTRUCTIONS
INSTRUCCIONES DE MONTAJE**

COD BR: HOMMY 04

Sumário Summary Resumen

Introdução Introduction Introducción	3
Antes de começar Before starting Antes de comenzar	4
Evite acidentes Avoid accidents Evitar accidentes	4
Dimensões e ferramentas Dimensions and tools Dimensiones y herramientas	5
Identificação das peças Identifying parts Identificación de las piezas	6
Acessórios incluídos na caixa Hardware included in box Accesorios incluidos en la caja	7
Montagem do móvel Furniture assembly Montaje del mueble	8

Introdução Introduction Introducción

Leia atentamente este manual e siga os passos indicados para que o produto não perca a garantia e também para uma perfeita montagem.

Read this manual and follow the steps in order to keep the guarantee and also for the perfect fit.

Lea este manual y siga los pasos para que el producto no pierda la garantía y también para el ajuste perfecto.

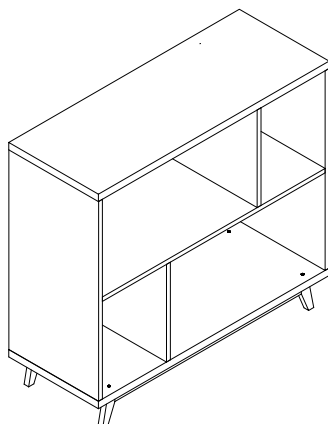

Antes de começar Before starting Antes de comenzar

Antes de começar a montagem prepare o ambiente, deixando-o completamente limpo e com bom espaço para iniciar o trabalho.

Prepare the room before starting the assembly, leaving it completely clean and the area in good condition to start the work.

Antes de comenzar el montaje preparar el ambiente, dejándolo completamente limpio y con bueno espacio para comenzar el trabajo.

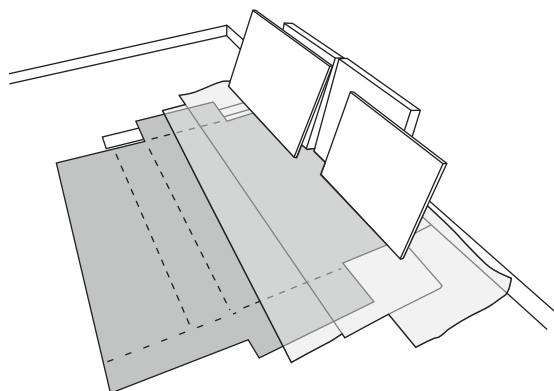

Utilize o papelão da própria embalagem para separar e apoiar as peças retiradas das caixas.

Use the cardboard of the packaging to separate and support the parts removed from the boxes.

Utilice el cartón de la embalaje para separar y apoyar las piezas desmontadas de las cajas.



Forre a área de montagem com um cobertor ou tapete. Assim, você evita avarias nas peças durante o processo de montagem.

Cover the assembly area with a blanket or carpet to avoid damaging the parts during the assembly process.

Cubrir la zona de ensamble con una manta o alfombra. De este modo, se evitan daños en las piezas durante el proceso de montaje.



Evite acidentes Avoid accidents Prevenir accidentes

Solicitamos observar atentamente as orientações de montagem como: fixação do produto na parede, colocação de cola em locais específicos necessários, o peso suportado pelo produto, etc...

We request you to carefully observe the assembly instructions as: fixing the product on the wall, adding glue in needed and specific places, product weight limit, etc.

Pedimos que lea atentamente las instrucciones, principalmente las informaciones de fijación del producto en la pared, colocación de pegamento en local específico y necesario, el peso soportado por el producto etc...

Não escale ou se apoie no móvel.

Do not climb or lean on the furniture.

No se suba ni se apoye en el mueble.

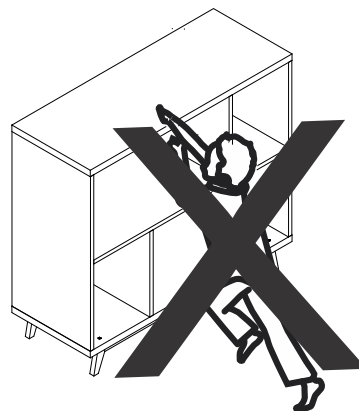

Dimensões e ferramentas
Dimensions and tools
Dimensiones y herramientas

Dimensões:

L: 902 A: 825 P: 351 mm

Dimensions:

W: 35.51 H: 32.48 D: 13.81 inches

Dimensiones:

L: 902 A: 825 P: 351 mm

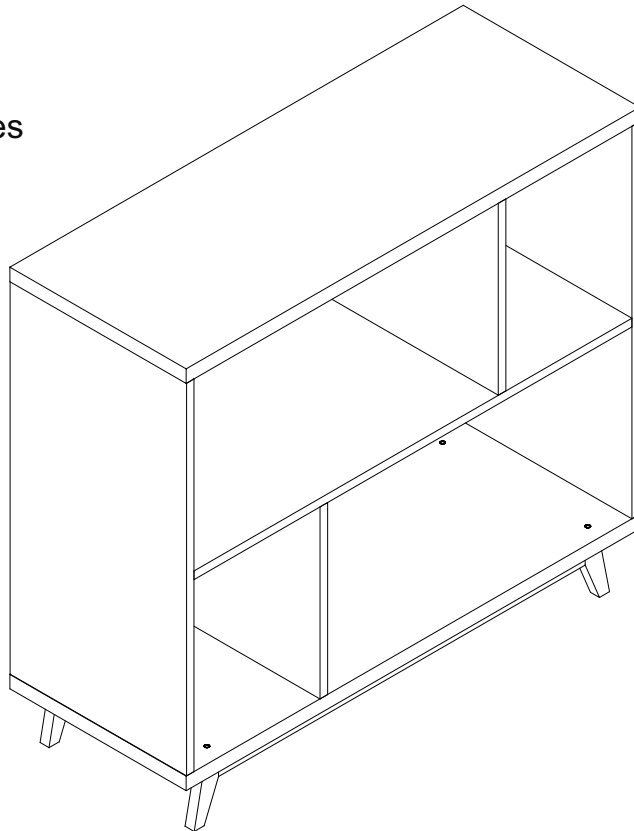

Limpeza
Cleaning
Limpieza

Pano levemente umedecido com água, seguido de pano seco, não utilizar produtos químico ou abrasivos.
Slightly dampened cloth and after a dry cloth, do not use chemicals or abrasives.
Solamente utilizar un paño húmedo y después un paño seco, no utilice productos químicos o abrasivos.

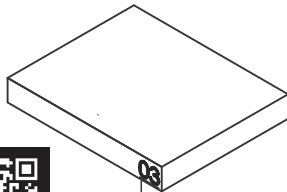

UTILIZE ALCOOL APENAS PARA REMOVER O NUMERO DAS PEÇAS
USE ALCOHOL ONLY TO REMOVE PART NUMBERS
UTILICE ALCOHOL SOLAMENTE PARA ELIMINAR EL NUMERO DE LAS PIEZAS

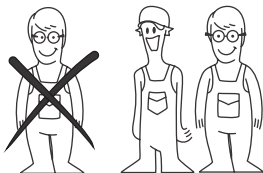

Para facilitar a montagem, utilize uma parafusadeira elétrica.
To improve assembly, use an electronic screwdriver.
Para facilitar el armado, utilice un destornillador eléctrico.

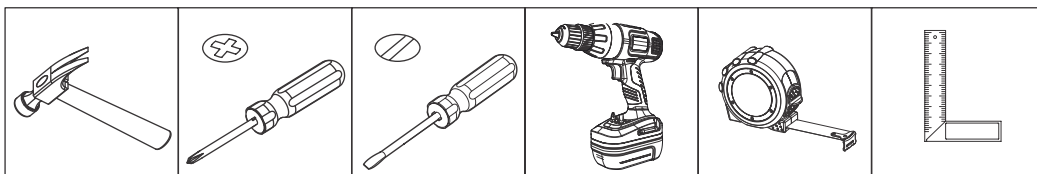

COD BR: HOMMY 04

PEÇA	DESCRIÇÃO	QUANT.	PART DESCRIPTION	QTY	PIEZA	DESCRIPCIÓN	CANTIDAD	
001	BASE	1	001	BASE	1	001	BASE	1
002	TAMPO	1	002	TOP	1	002	TAPA	1
003	LATERAL	2	003	SIDE	2	003	LATERAL	2
004	PRATELEIRA	1	004	SHELF	1	004	REPISA	1
005	DIVISÓRIA	2	005	PARTITION	2	005	PARTICIÓN	2
006	PÉS	2	006	FEET	2	006	PIES	2

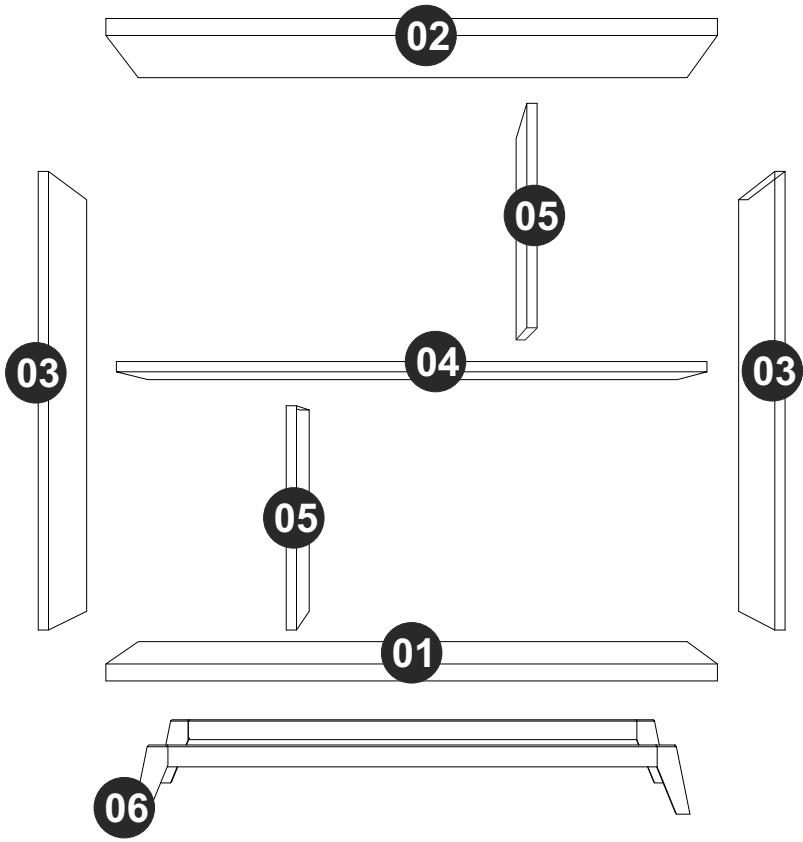



TAPA FUROS x 16
STICKER x 16
TAPAS PLÁSTICAS x 16

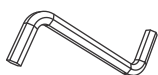

EF 000741 x 1

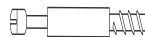

EF 000094 X 12



EF 000033 x 20
8x30



EF 000745 x 4
5X40



EF 000132 x 8
4X50 CC



EF 000216 X 12



GIZ x 01
CHALK x 01
TIZA x 01

A = 12KG - 26.45LB

B = 7KG - 15.43LB

C = 3KG - 6.61LB

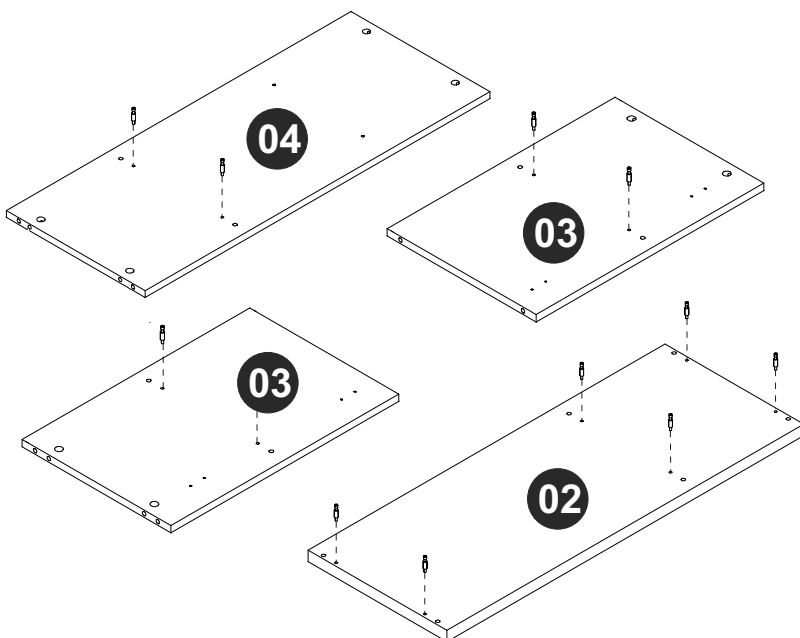
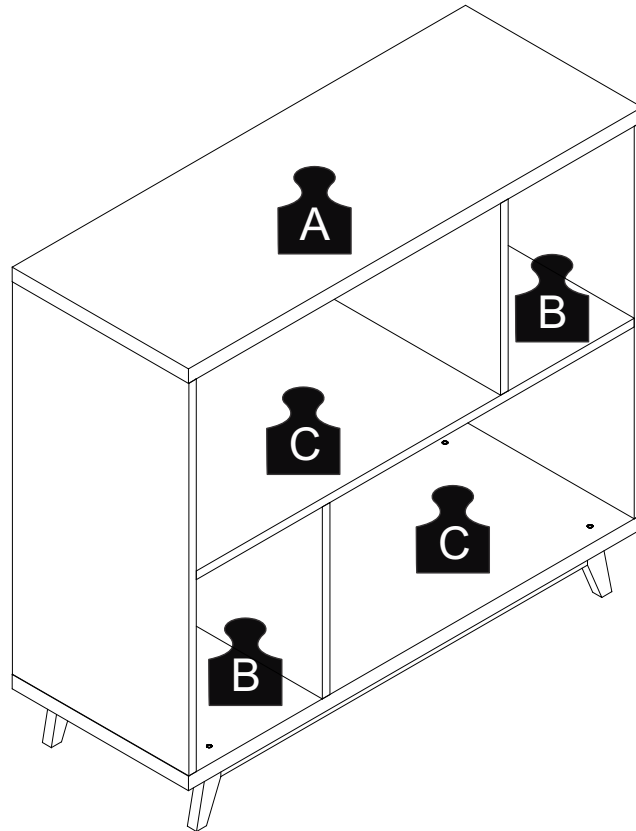

PASSO 1 / STEP 1 / PASO 1

Fixe a ferragem EF 000094 nas peças 02, 03 e 04.
Fix hardware EF 000094 in pieces 02, 03 and 04.
Fije el herraje EF 000094 en las piezas 02, 03 y 04.

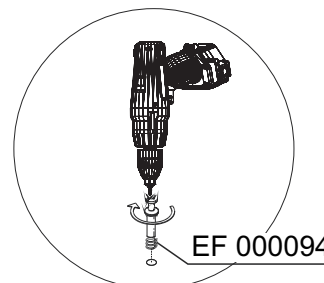

PASSO 2 / STEP 2 / PASO 2

Insira a ferragem EF 000033 nas peças 03.
Insert hardware EF 000033 into pieces 03.
Añade el herraje EF 000033 en las piezas 03.

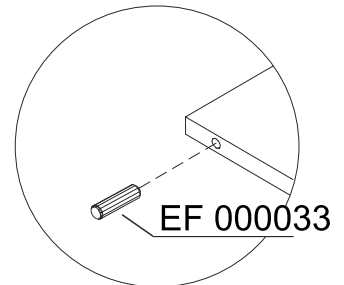
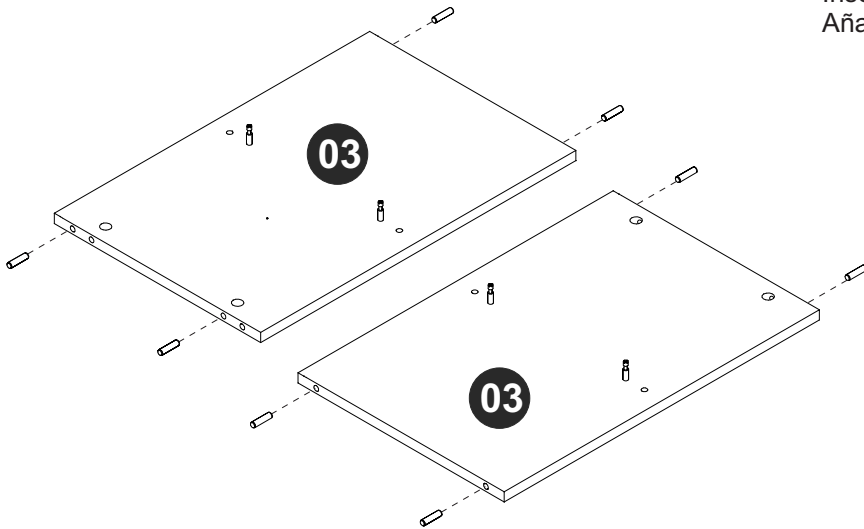

PASSO 3 / STEP 3 / PASO 3

Insira a ferragem EF 000033 nas peças 04 e 05.
Insert hardware EF 000033 in pieces 04 and 05.
Añade el herraje EF 000033 en las piezas 04 y 05.

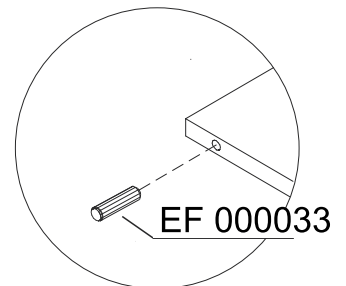
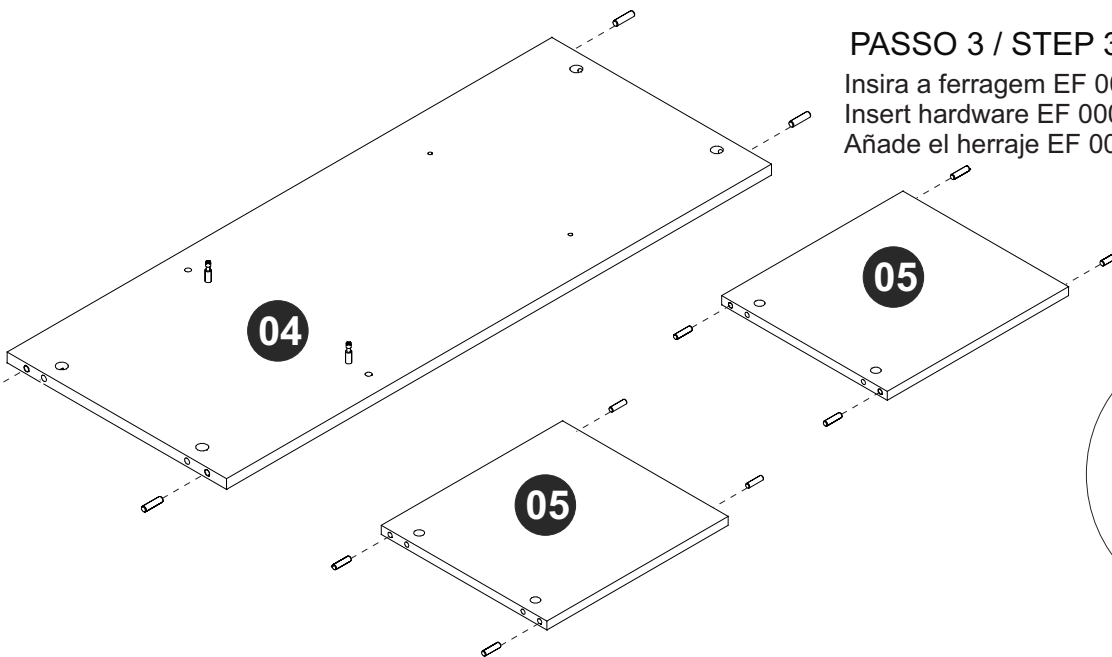

PASSO 4 / STEP 4 / PASO 4

Fixe as peças 06 à peça 01 utilizando a ferragem EF 000745 e EF 000741.
Fix pieces 06 to piece 01 using hardware EF 000745 and EF 000741.
Junte las piezas 01 y 06 utilizando los herrajes EF 000745 y EF 000741.

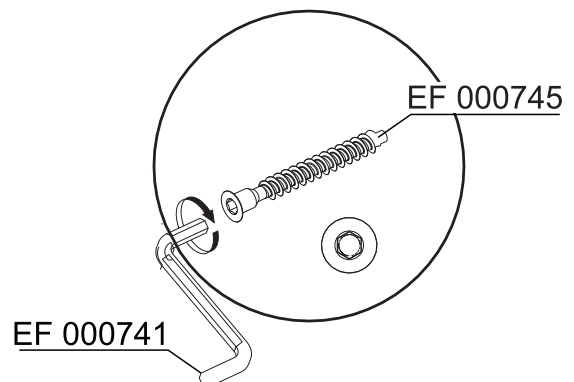
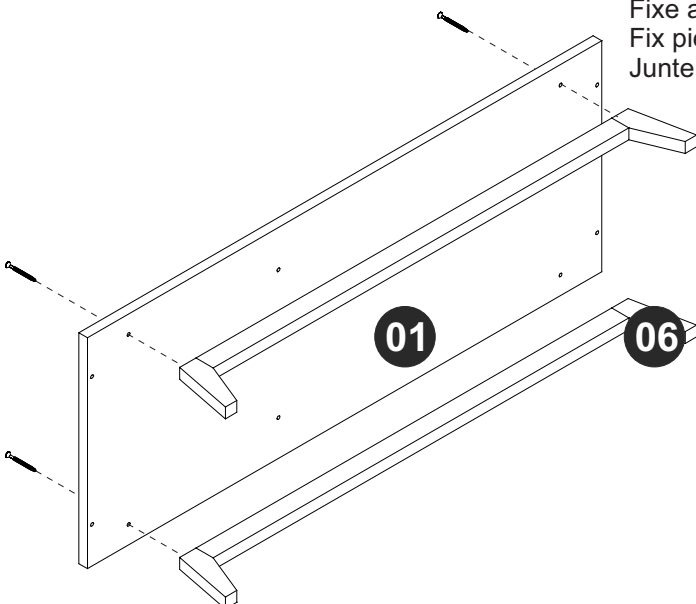

PASSO 5 / STEP 5 / PASO 5

Utilize as ferragens EF 000216 e EF 000132 para conectar as peças 04 e 05.
Após inserir, gire a ferragem EF 000216 para apertar.
Use hardwares EF 000216 and EF 000132 to connect pieces 04 and 05.
After inserting, turn hardware EF 000216 to tighten.
Utilice los herrajes EF 000216 y EF 000132 para juntar las piezas 04 y 05.
Después de añadir, gire el herraje EF 000216 para apretar.

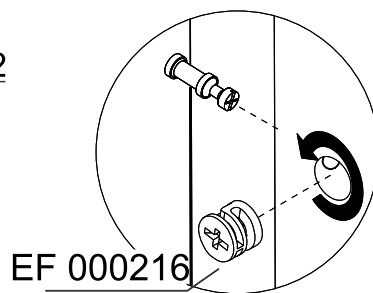
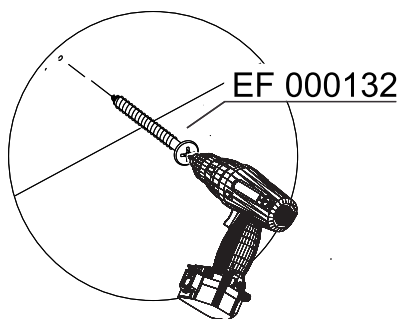
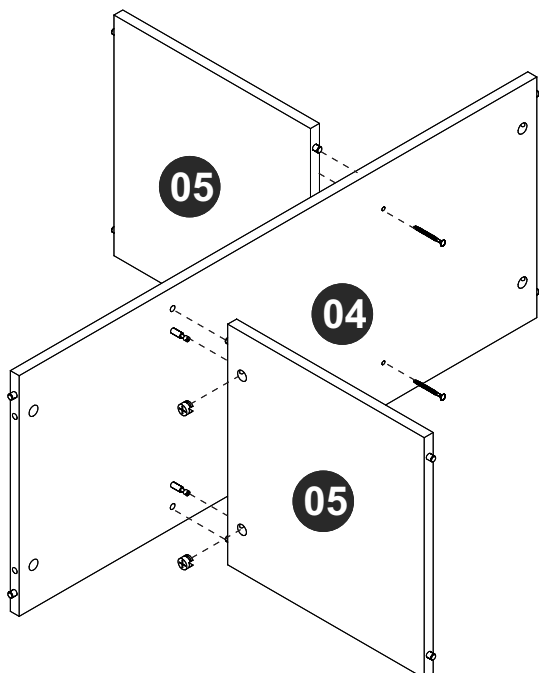

PASSO 6 / STEP 6 / PASO 6

Conecte a parte montada no passo anterior e as peças 03, insira a ferragem EF 000216 e gire para apertar.
Connect the part assembled in the previous step and pieces 03, insert hardware EF 000216 and turn to tighten.
Junte la parte armada en el paso anterior y las piezas 03, añade el herraje EF 000216 y gire para apretar.

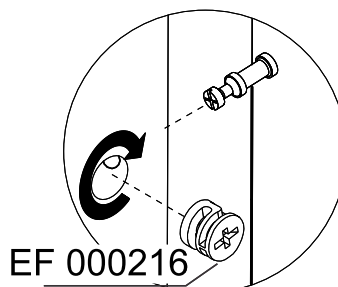
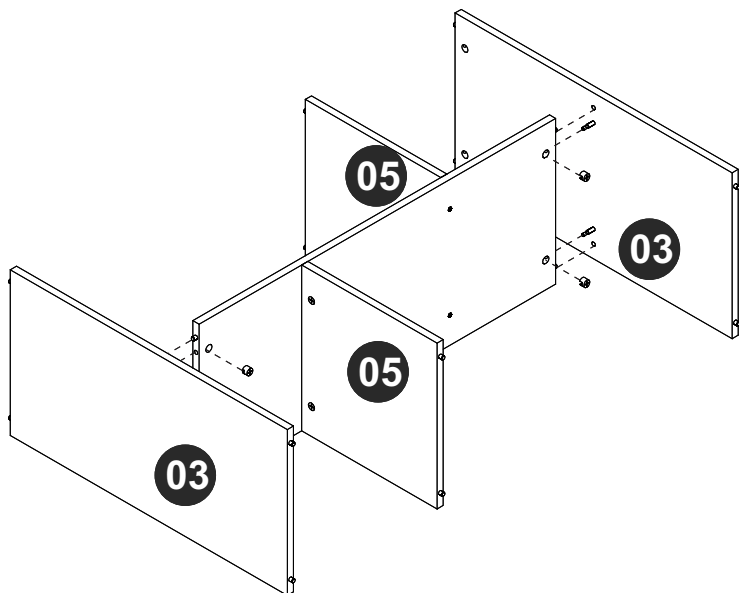

PASSO 7 / STEP 7 / PASO 7

Conecte a parte montada no passo anterior e a peça 02, insira a ferragem EF 000216 e gire para apertar.
Connect the part assembled in the previous step and piece 02, insert hardware EF 000216 and turn to tighten.
Junte la parte armada en el paso anterior y la pieza 02, añade el herraje EF 000216 y gire para apretar.

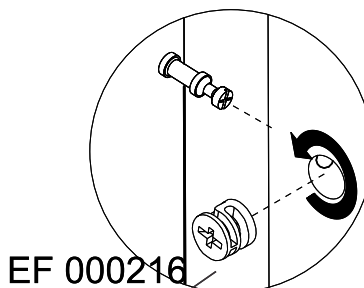
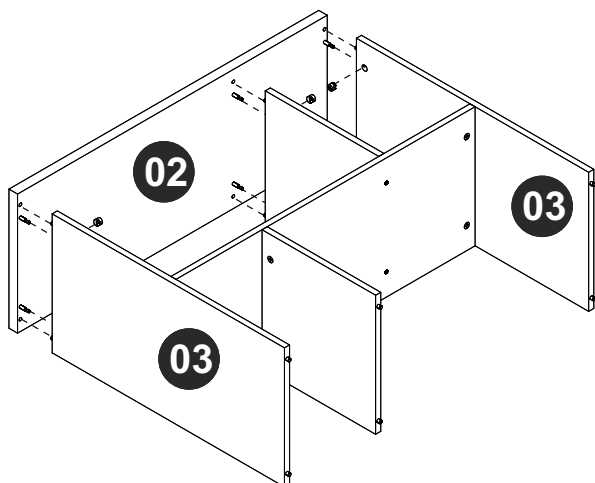

PASSO 8 / STEP 8 / PASO 8

Conecte as partes montadas nos passos 4 e 7 utilizando a ferragem EF 000132.
Connect the parts assembled in the steps 4 and 7 using hardware EF 000132.
Junte las partes armadas en los pasos 4 y 7 utilizando el herraje EF 000132.

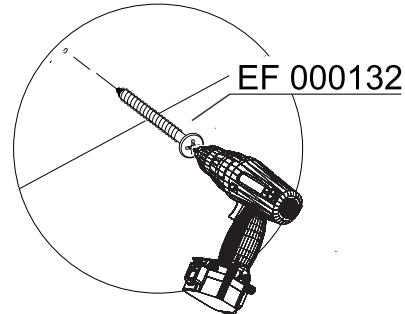
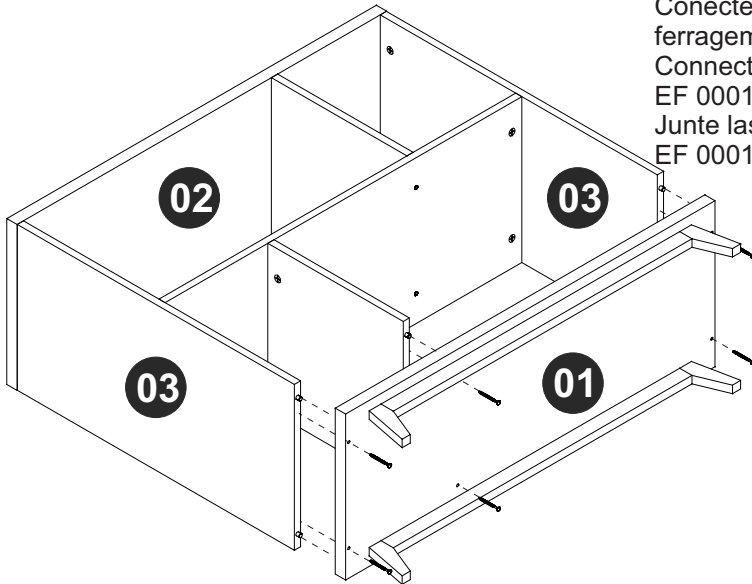

PASSO 9 / STEP 9 / PASO 9

Use os tapa furos para cobrir os parafusos aparentes.
Use o giz para dar o acabamento final ao produto.
Use stickers to cover apparent screws.
Use the chalk to give the final finish on the product.
Utilice los tapa huecos para cubrir los tornillos aparentes.
Utilice la tiza para dar el acabado final al producto.

