

HOMMY 01-W

HOMMY 01-B



MANUAL DE MONTAGEM
ASSEMBLY INSTRUCTIONS
INSTRUCCIONES DE MONTAJE

Introdução..... 3 <i>Introduction</i> <i>Introducción</i>	Identificação das peças..... 6 <i>Identifying parts</i> <i>Identificación de las piezas</i>
Evite acidentes..... 3 <i>Avoid accidents</i> <i>Evitar accidentes</i>	Acessórios incluídos na caixa..... 7 <i>Hardware included in box</i> <i>Accesorios incluidos en la caja</i>
Antes de começar..... 4 <i>Before Starting</i> <i>Antes de comenzar</i>	Capacidade..... 8 <i>Weight Capacity</i> <i>Peso Sopoado</i>
Dimensões e ferramentas..... 5 <i>Dimensions and tools</i> <i>Dimensiones y herramientas</i>	Montagem do móvel..... 8 <i>Furniture assembly</i> <i>Montaje del mueble</i>

Introdução / Introduction / Introducción

Leia atentamente este manual e siga os passos indicados para que o produto não perca a garantia e também para uma perfeita montagem.

Read this manual and follow the steps in order to keep the guarantee and also for the perfect fit.

Lea este manual y siga los pasos para que el producto no pierda la garantía y también para el ajuste perfecto.

Evite acidentes / Avoid accidents / Prevenir accidentes

Solicitamos observar atentamente as orientações de montagem como: fixação do produto na parede, colocação de cola em locais específicos necessários, o peso suportado pelo produto, etc...

We request you to carefully observe the assembly instructions as: fixing the product on the wall, adding glue in needed and specific places, product weight limit, etc.

Pedimos que lea atentamente las instrucciones, principalmente las informaciones de fijación del producto en la pared, colocación de pegamento en local específico y necesario, el peso soportado por el producto etc...



Não escale ou se apoie no móvel.
Do not climb or lean on the furniture.
No se suba ni se apoye en el mueble.

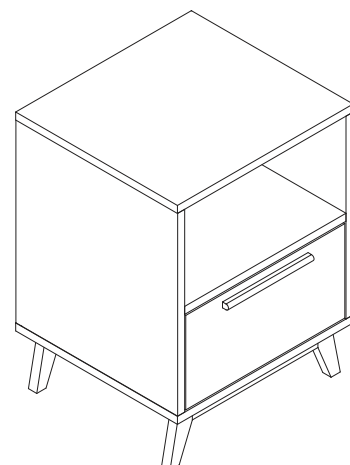

Antes de começar / Before starting / Antes de comenzar

Antes de começar a montagem prepare o ambiente, deixando-o completamente limpo e com bom espaço para iniciar o trabalho.

Prepare the room before starting the assembly, leaving it completely clean and the area in good condition to start the work.

Antes de comenzar el montaje preparar el ambiente, dejándolo completamente limpio y con bueno espacio para comenzar el trabajo.

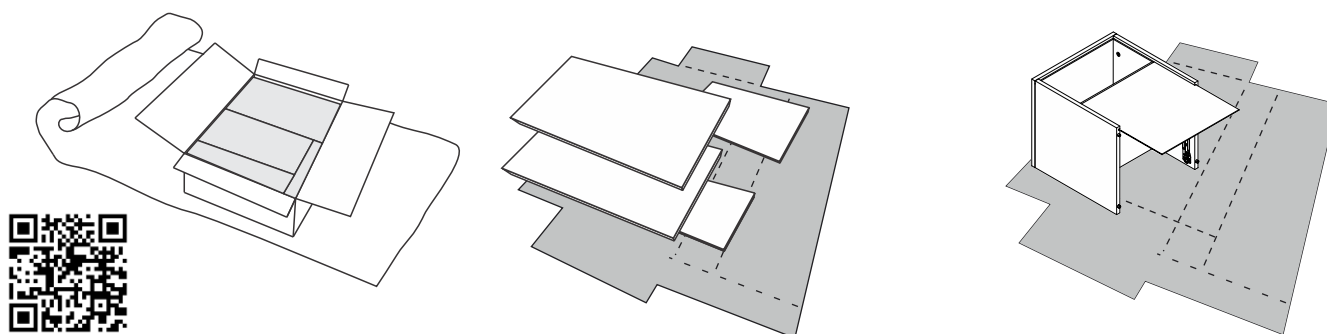

Utilize o papelão da própria embalagem para separar e apoiar as peças retiradas das caixas.

Use the cardboard of the packaging to separate and support the parts removed from the boxes.

Utilice el cartón de la embalaje para separar y apoyar las piezas desmontadas de las cajas.

Forre a área de montagem com um cobertor ou tapete. Assim, você evita avarias nas peças durante o processo de montagem.

Cover the assembly area with a blanket or carpet to avoid damaging the parts during the assembly process.

Cubrir la zona de ensamble con una manta o alfombra. De este modo, se evitan daños en las piezas durante el proceso de montaje.

Limpeza / Cleaning / Limpieza

Pano levemente umedecido com água, seguido de pano seco, não utilizar produtos químicos ou abrasivos.

Slight dampened cloth and after a dry cloth, do not use chemicals or abrasives.

Solamente utilizar un paño húmedo y después un paño seco, no utilice productos químicos o abrasivos.

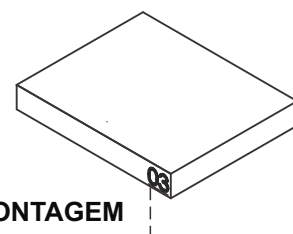

UTILIZE ALCOOL APENAS PARA REMOVER O NUMERO DAS PEÇAS APÓS A MONTAGEM
USE ALCOHOL ONLY TO REMOVE PART NUMBERS AFTER ASSEMBLY

UTILICE ALCOHOL SOLAMENTE PARA ELIMINAR EL NUMERO DE LAS PIEZAS DESPUÉS DEL MONTAJE

Dimensões e ferramentas / Dimensiones artdols / Dimensiones y herramientas

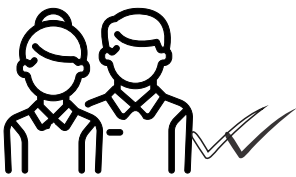
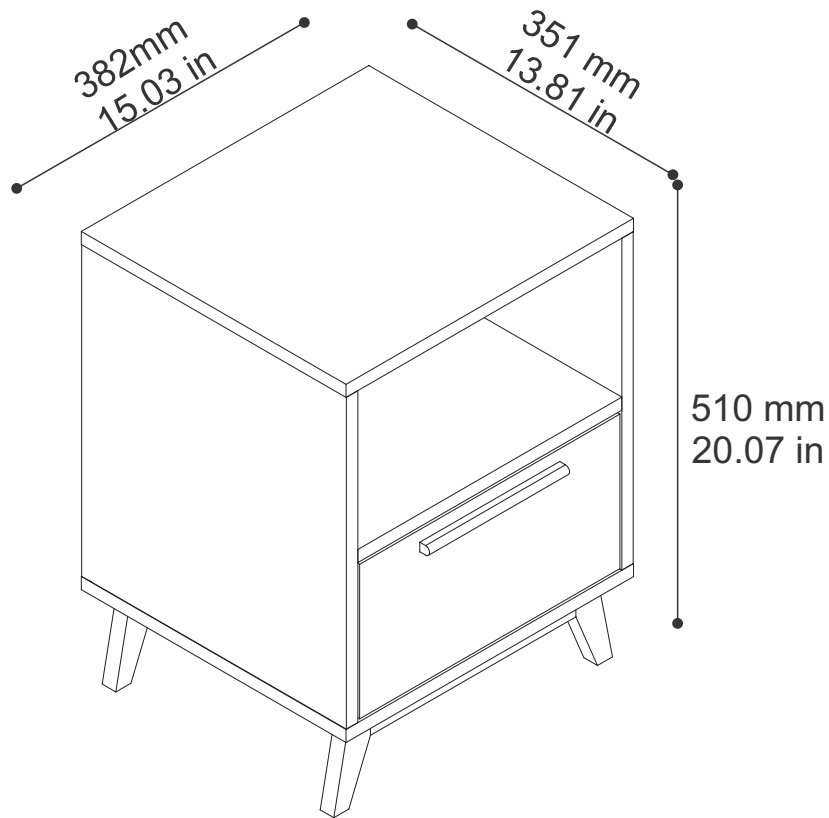

Será necessário auxílio para facilitar a montagem.
You may need help to assembly easier.
Se necesitará ayuda para facilitar el armado.

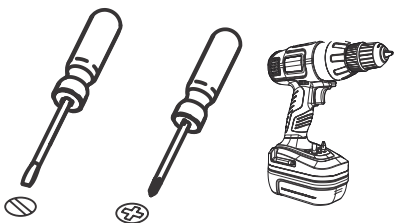

Para facilitar a montagem, utilize uma parafusadeira elétrica.
To improve assembly, use an electronic screwdriver.
Para facilitar el armado, utilice un destornillador eléctrico.

Identificação das peças / Identifying parts / Identificación de las piezas

PEÇA	DESCRIÇÃO	QUNT.	PART DESCRIPTION	QTY	PIEZA DESCRIPCIÓN	CANTIDAD																																																						
001	BASE	1	001 BASE	1	001 BASE	1																																																						
002	TAMPO	1	002 TOP	1	002 TAPA	1																																																						
003	LATERAL ESQUERDA	1	003 LEFT SIDE	1	003 LATERAL IZQUIERDA	1																																																						
004	LATERAL DIREITA	1	004 RIGHT SIDE	1 </tr <tr> <td>005</td> <td>PRATELEIRA</td> <td>1</td> <td>005 SHELF</td> <td>1</td> <td>005 REPISA</td> <td>1</td> </tr> <tr> <td>006</td> <td>FRENTE DE GAVETA</td> <td>1</td> <td>006 FRONT DRAWER</td> <td>1</td> <td>006 FRENTE CAJÓN</td> <td>1</td> </tr> <tr> <td>007</td> <td>COSTA</td> <td>1</td> <td>007 BACK</td> <td>1</td> <td>007 REVÉS</td> <td>1</td> </tr> <tr> <td>008</td> <td>FUNDO GAVETA</td> <td>1</td> <td>008 BOTTOM DRAWER</td> <td>1</td> <td>008 FONDO CAJÓN</td> <td>1</td> </tr> <tr> <td>009</td> <td>PÉS</td> <td>2</td> <td>009 FEET</td> <td>2</td> <td>009 PIES</td> <td>2</td> </tr> <tr> <td>020</td> <td>LATERAL DIREITA GAVETA</td> <td>1</td> <td>020 RIGHT SIDE DRAWER</td> <td>1</td> <td>020 LATERAL DERECHA CAJÓN</td> <td>1</td> </tr> <tr> <td>021</td> <td>COSTA GAVETA</td> <td>1</td> <td>021 BACK DRAWER</td> <td>1</td> <td>021 REVÉS CAJÓN</td> <td>1</td> </tr> <tr> <td>022</td> <td>LATERAL ESQUERDA GAVETA</td> <td>1</td> <td>022 LEFT SIDE DRAWER</td> <td>1</td> <td>022 LATERAL IZQUIERDA CAJÓN</td> <td>1</td> </tr>	005	PRATELEIRA	1	005 SHELF	1	005 REPISA	1	006	FRENTE DE GAVETA	1	006 FRONT DRAWER	1	006 FRENTE CAJÓN	1	007	COSTA	1	007 BACK	1	007 REVÉS	1	008	FUNDO GAVETA	1	008 BOTTOM DRAWER	1	008 FONDO CAJÓN	1	009	PÉS	2	009 FEET	2	009 PIES	2	020	LATERAL DIREITA GAVETA	1	020 RIGHT SIDE DRAWER	1	020 LATERAL DERECHA CAJÓN	1	021	COSTA GAVETA	1	021 BACK DRAWER	1	021 REVÉS CAJÓN	1	022	LATERAL ESQUERDA GAVETA	1	022 LEFT SIDE DRAWER	1	022 LATERAL IZQUIERDA CAJÓN	1
005	PRATELEIRA	1	005 SHELF	1	005 REPISA	1																																																						
006	FRENTE DE GAVETA	1	006 FRONT DRAWER	1	006 FRENTE CAJÓN	1																																																						
007	COSTA	1	007 BACK	1	007 REVÉS	1																																																						
008	FUNDO GAVETA	1	008 BOTTOM DRAWER	1	008 FONDO CAJÓN	1																																																						
009	PÉS	2	009 FEET	2	009 PIES	2																																																						
020	LATERAL DIREITA GAVETA	1	020 RIGHT SIDE DRAWER	1	020 LATERAL DERECHA CAJÓN	1																																																						
021	COSTA GAVETA	1	021 BACK DRAWER	1	021 REVÉS CAJÓN	1																																																						
022	LATERAL ESQUERDA GAVETA	1	022 LEFT SIDE DRAWER	1	022 LATERAL IZQUIERDA CAJÓN	1																																																						

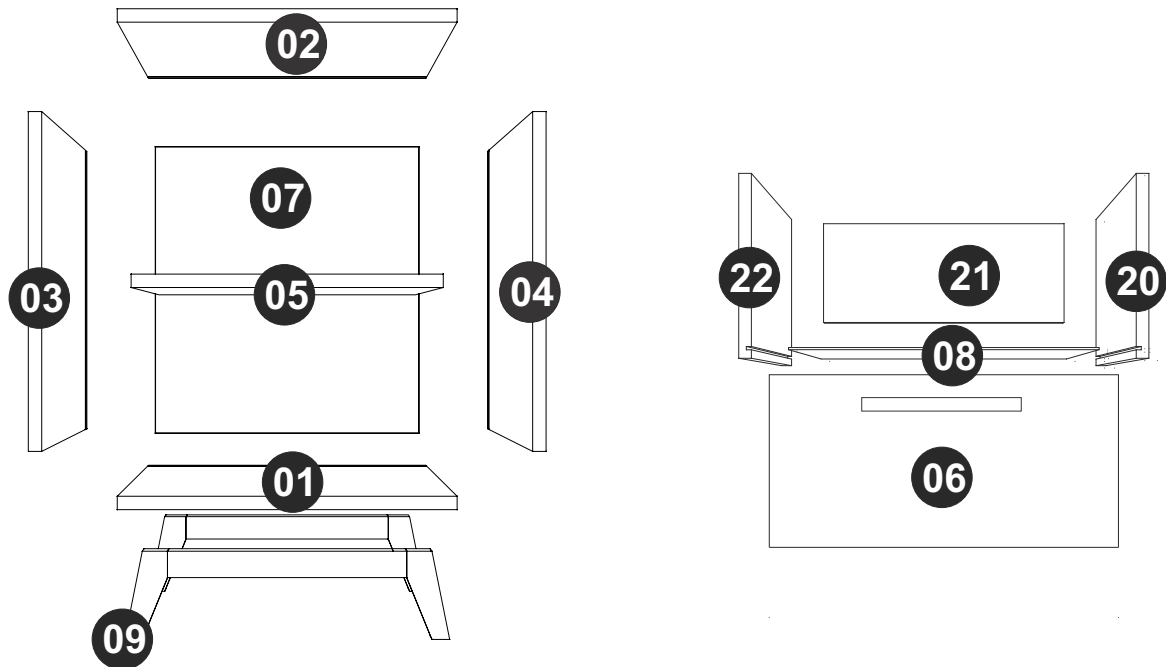

Acessórios incluídos na caixa *Hardware included in box* / *acessorios incluídos en laja*

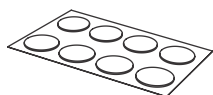

TAPA FUROS - 12
STICKER - 12
TAPAS PLÁSTICAS - 12

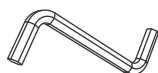

EF 000741 - 1

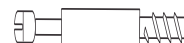

EF 000094 - 12



EF 000745 - 4



EF 000132 - 4



EF 000381 x 2

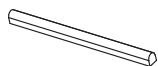

PUXADOR - 1
HANDLE - 1
MANIJA - 1



EF 000216 - 12



EF 000033 - 20



GIZ - 1
CHALK - 1
TIZA - 1

Capacidade/ Weight Capacity / Peso Soportado



4KG - 8.81LB



2KG - 4.4LB

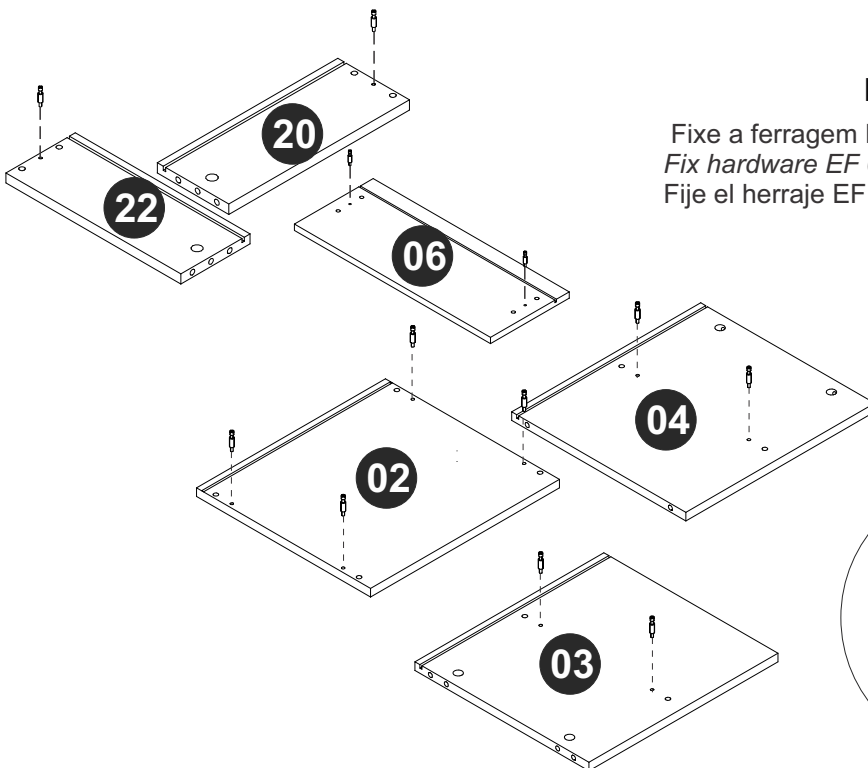
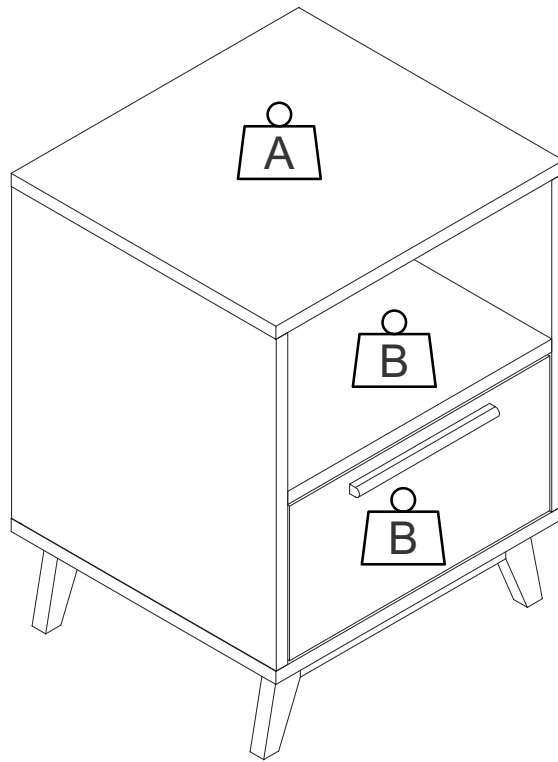

PASSO 1 / STEP 1 / PASO 1

Fixe a ferragem EF 000094 nas peças 02, 03, 04, 06, 20 e 22.

Fix hardware EF 000094 in pieces 02, 03, 04, 06, 20 and 22.

Fije el herraje EF 000094 en las piezas 02, 03, 04, 06, 20 y 22.

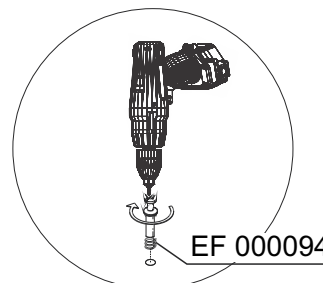

PASSO 2 / STEP 2 / PASO 2

Insira a ferragem EF 000033 nas peças 03, 04 e 05.
Insert hardware EF 000033 into pieces 03, 04 and 05.
Añade el herraje EF 000033 en las piezas 03, 04 y 05.

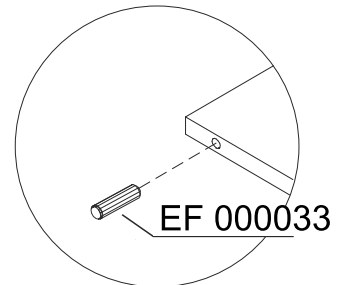
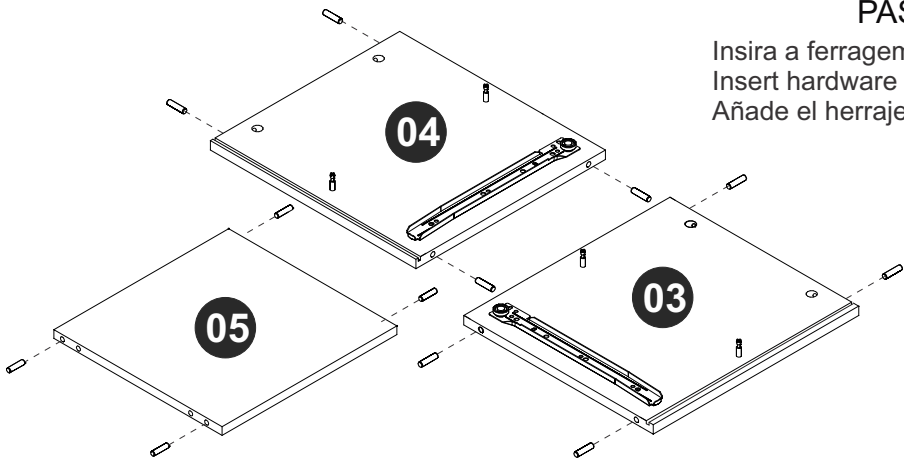

PASSO 3 / STEP 3 / PASO 3

Insira a ferragem EF 000033 nas peças 20, 21 e 22.
Insert hardware EF 000033 in pieces 20, 21 and 22.
Añade el herraje EF 000033 en las piezas 20, 21 y 22.

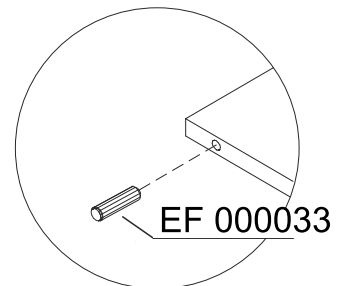
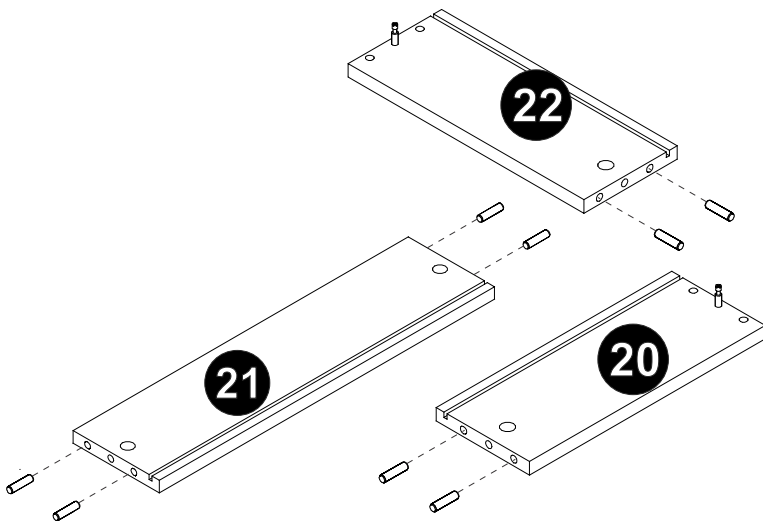

PASSO 4 / STEP 4 / PASO 4

Fixe as peças 09 à peça 01 utilizando a ferragem EF 000745 e EF 000741.
Fix pieces 09 to piece 01 using hardware EF 000745 and EF 000741.
Junte las piezas 01 y 09 utilizando los herrajes EF 000745 y EF 000741.

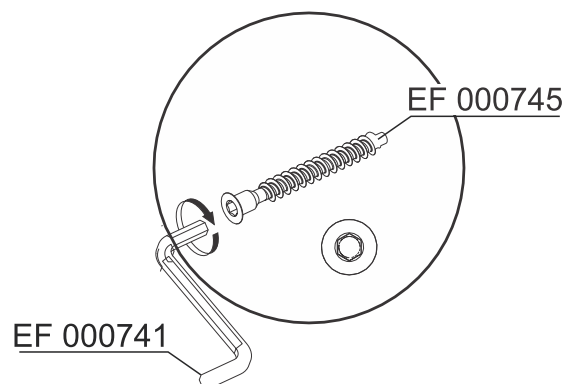
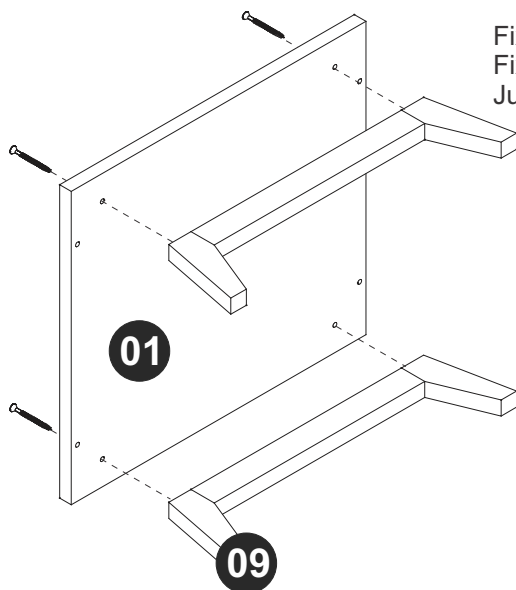

PASSO 5 / STEP 5 / PASO 5

Conecte as peças 03, 04 e 05, insira a ferragem EF 000216 e gire para apertar.
Connect pieces 03, 04 and 05, insert hardware EF 000216 and turn to tighten.
Junte las piezas 03, 04 y 05, añada el herraje EF 000216 y gire para apretar.

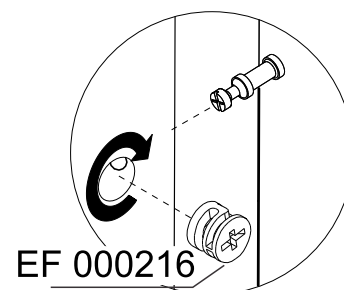
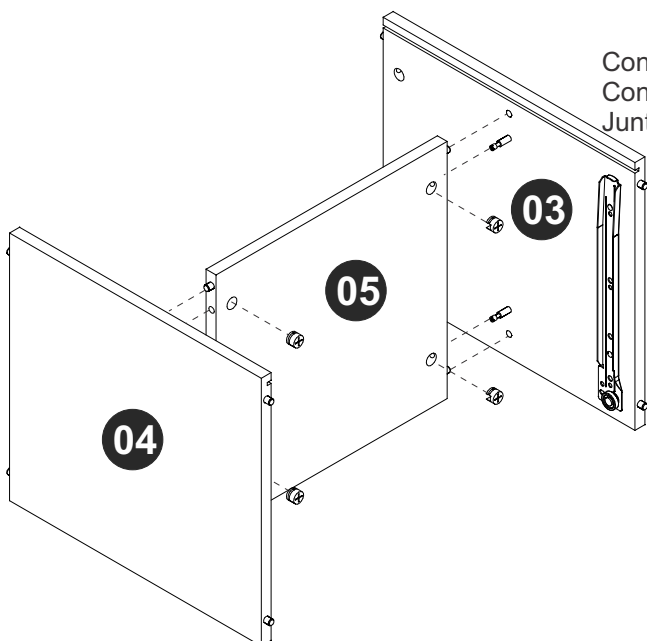

Por favor, note a posição da corredeira.
Please, note the drawer tracks position.
Por favor notar la posición de las correderas.

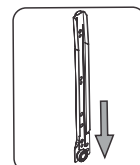

PASSO 6 / STEP 6 / PASO 6

Conecte a peça 02 à parte montada no passo anterior, insira a ferragem EF 000216 e gire para apertar.
Connect piece 02 to the part assembled in the previous step, insert hardware EF 000216 and turn to tighten.
Junte la pieza 02 a la parte armada en el paso anterior, añada el herraje EF 000216 y gire para apretar.

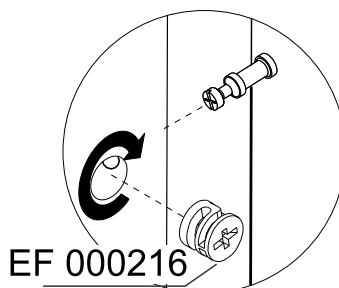
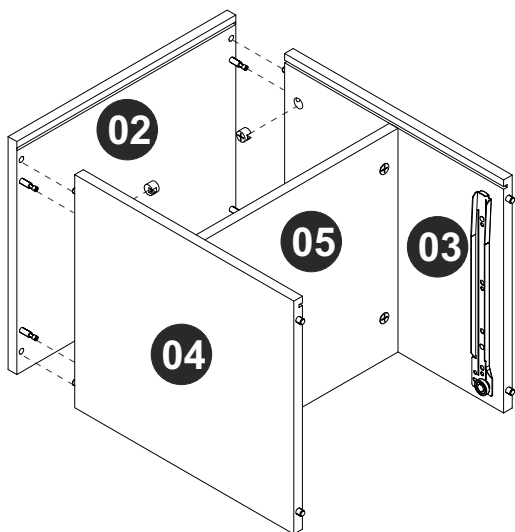

Por favor, note a posição da corredeira.
Please, note the drawer tracks position.
Por favor notar la posición de las correderas.

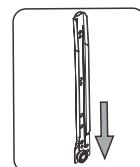

PASSO 7 / STEP 7 / PASO 7

Encaixe a peça 07 entre os espaços específicos nas peças 03 e 04.
Fit piece 07 in the specific spaces in pieces 03 and 04.
Fije la pieza 07 entre los espacios específicos en las piezas 03 y 04.

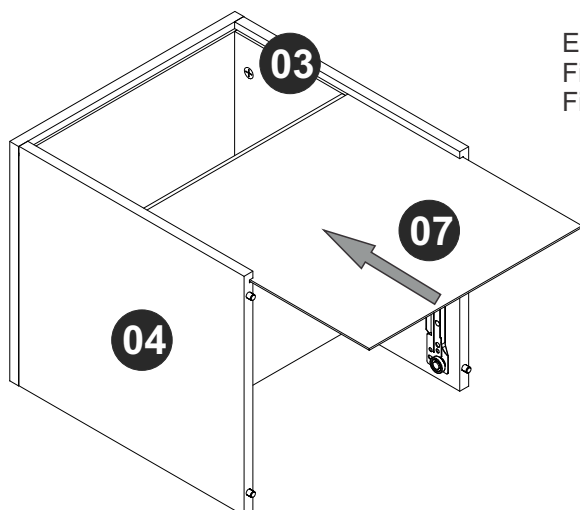

Por favor, note a posição da corredeira.
Please, note the drawer tracks position.
Por favor notar la posición de las correderas.

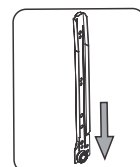

PASSO 8 / STEP 8 / PASO 8

Conecte as partes montadas nos passos 4 e 7 utilizando a ferragem EF 000132.

Connect the parts assembled in the steps 4 and 7 using hardware EF 000132.

Junte las partes armadas en los pasos 4 y 7 utilizando el herraje EF 000132.

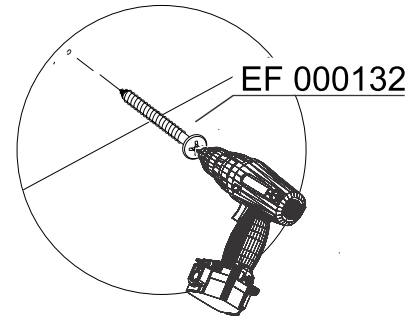
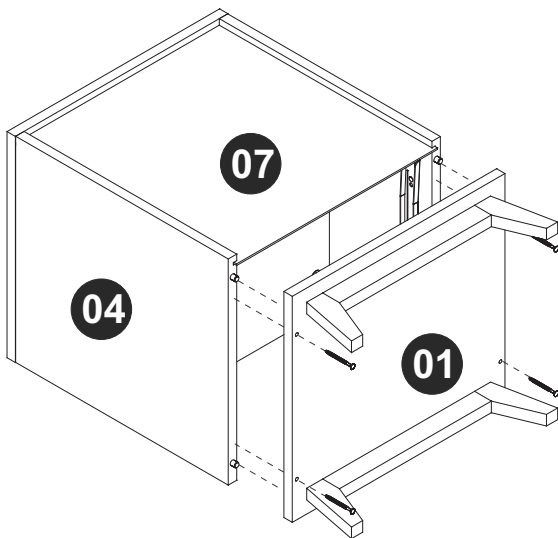

PASSO 9 / STEP 9 / PASO 9

Conecte as peças 20, 21 e 22, insira e gire a ferragem EF 000216 até apertar

Connect pieces 20, 21 and 22, insert hardware EF 000216 and turn to tighten.

Junte las piezas 20, 21 y 22. Añade y gire el herraje EF000216 hasta apretar

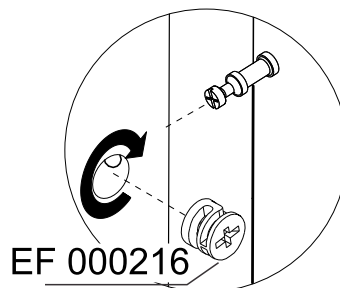
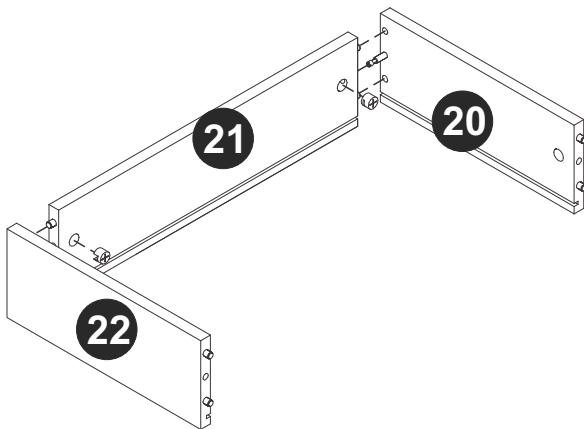

PASSO 10 / STEP 10 / PASO 10

Encaixe a peça 08 entre os espaços específico nas peças 20 e 22.

Fit piece 08 in the specific spaces in pieces 20 and 22.

Fije la pieza 08 entre los espacios específicos en las piezas 20 y 22.

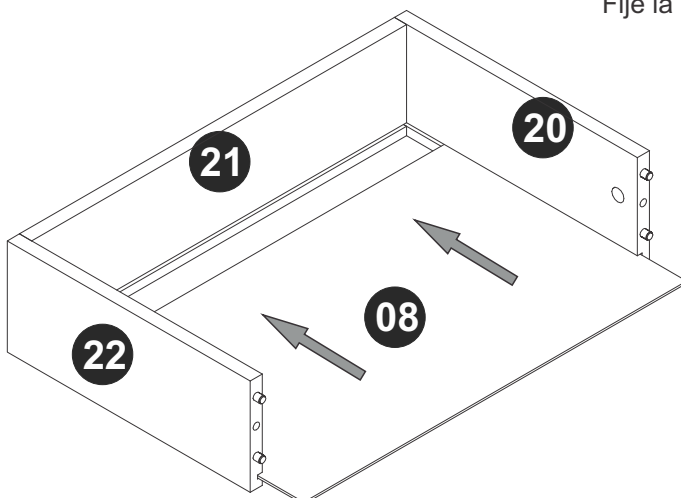

PASSO 11 / STEP 11 / PASO 11

Conecte a peça 06, insira a ferragem EF 000216 e gire para apertar. Fixe o puxador utilizando a ferragem EF 000381.
Connect piece 06, insert hardware EF 000216 and turn to tighten. Attach the handle using hardware EF 000381.
Junte la pieza 06, añada el herraje EF 000216 y gire para apretar. Fije la manija utilizando el herraje EF 000381.

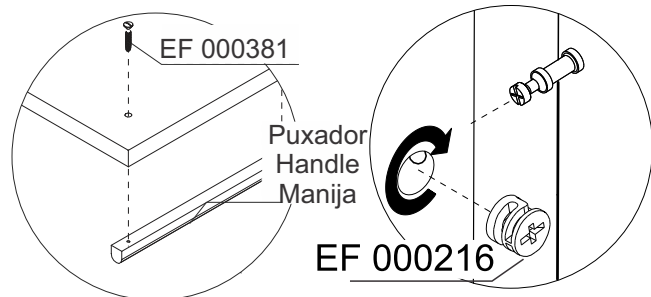
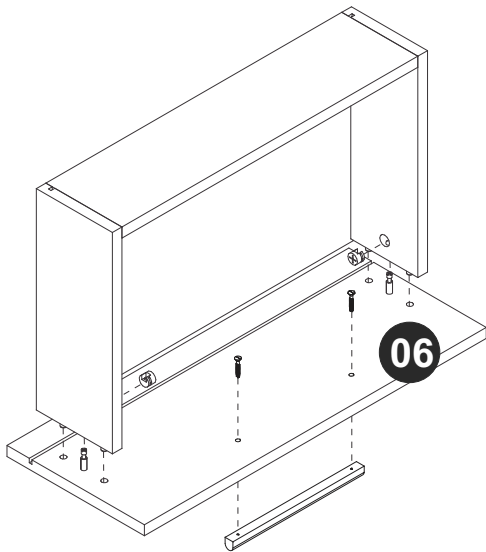

PASSO 12 / STEP 12 / PASO 12

Coloque a gaveta no móvel montado.
Fit the drawer into assembled furniture.
Coloque el cajón en el mueble armado.

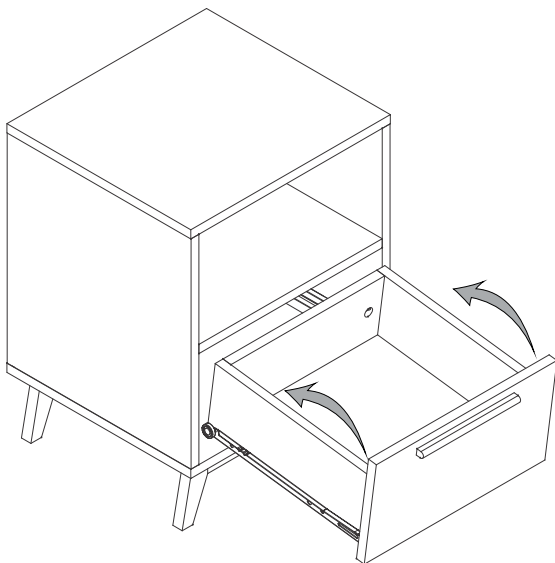

PASSO 13 / STEP 13 / PASO 13

Use os tapa furos para cobrir os parafusos aparentes.
Use o giz para dar o acabamento final ao produto.
Use stickers to cover apparent screws.
Use the chalk to give the final finish on the product.
Utilice los tapa huecos para cubrir los tornillos aparentes.
Utilice la tiza para dar el acabado final al producto.

