



**MANUAL DE MONTAGEM
ASSEMBLY INSTRUCTIONS
INSTRUCCIONES DE MONTAJE**

COD BR: BBN 18

Sumário Summary Resumen

Introdução Introduction Introducción	3
Antes de começar Before starting Antes de comenzar	4
Evite acidentes Avoid accidents Evitar accidentes	4
Dimensões e ferramentas Dimensions and tools Dimensiones y herramientas	5
Identificação das peças Identifying parts Identificación de las piezas	6
Acessórios incluídos na caixa Hardware included in box Accesorios incluidos en la caja	7
Montagem do móvel Furniture assembly Montaje del mueble	8

Introdução Introduction Introducción

Leia atentamente este manual e siga os passos indicados para que o produto não perca a garantia e também para uma perfeita montagem.

Read this manual and follow the steps in order to keep the guarantee and also for the perfect fit.

Lea este manual y siga los pasos para que el producto no pierda la garantía y también para el ajuste perfecto.

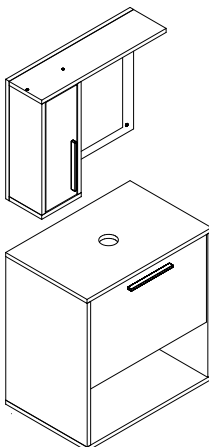

Antes de começar Before starting Antes de comenzar

Antes de começar a montagem prepare o ambiente, deixando-o completamente limpo e com bom espaço para iniciar o trabalho.

Prepare the room before starting the assembly, leaving it completely clean and the area in good condition to start the work.

Antes de comenzar el montaje preparar el ambiente, dejándolo completamente limpio y con bueno espacio para comenzar el trabajo.

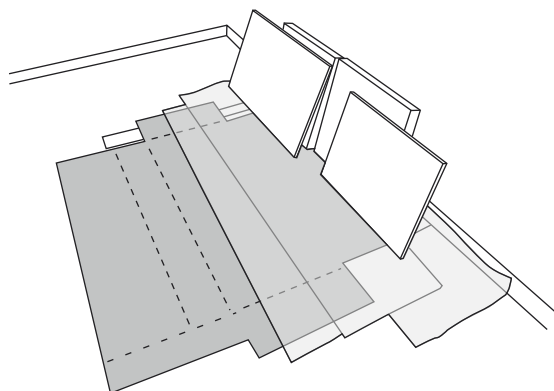

Utilize o papelão da própria embalagem para separar e apoiar as peças retiradas das caixas.

Use the cardboard of the packaging to separate and support the parts removed from the boxes.

Utilice el cartón de la embalaje para separar y apoyar las piezas desmontadas de las cajas.



Forre a área de montagem com um cobertor ou tapete. Assim, você evita avarias nas peças durante o processo de montagem.

Cover the assembly area with a blanket or carpet to avoid damaging the parts during the assembly process.

Cubrir la zona de ensamble con una manta o alfombra. De este modo, se evitan daños en las piezas durante el proceso de montaje.



Evite acidentes Avoid accidents Prevenir accidentes

Solicitamos observar atentamente as orientações de montagem como: fixação do produto na parede, colocação de cola em locais específicos necessários, o peso suportado pelo produto, etc...

We request you to carefully observe the assembly instructions as: fixing the product on the wall, adding glue in needed and specific places, product weight limit, etc.

Pedimos que lea atentamente las instrucciones, principalmente las informaciones de fijación del producto en la pared, colocación de pegamento en local específico y necesario, el peso soportado por el producto etc...

Não escale ou se apoie no móvel.

Do not climb or lean on the furniture.

No se suba ni se apoye en el mueble.

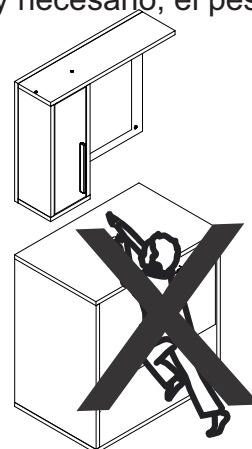

Dimensões e ferramentas
 Dimensions and tools
 Dimensiones y herramientas

Dimensões:
 L: 535 A: 445 P: 155 mm
 Dimensions:
 W: 21.06 H: 17.51 D: 6.10 inches
 Dimensiones:
 L: 565 A: 535 P: 350mm

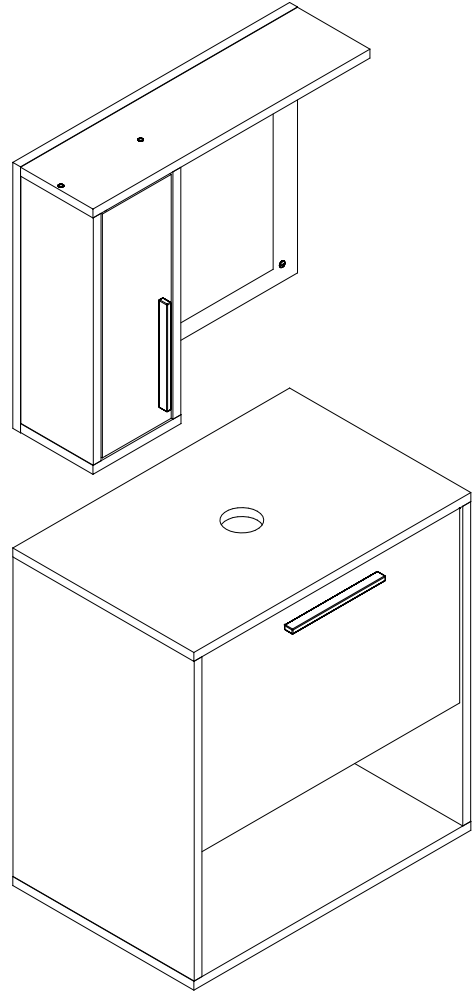

Dimensões:
 L: 535 A: 565 P: 350 mm
 Dimensions:
 W: 21.06 H: 22.24 D: 13.77 inches
 Dimensiones:
 L: 535 A: 565 P: 350 mm

Limpeza
 Cleanig
 Limpieza



Pano levemente umedecido com água, seguido de pano seco, não utilizar produtos químico ou abrasivos.
 Slightly dampened cloth and after a dry cloth, do not use chemicals or abrasives.
 Solamente utilizar un paño húmedo y después un paño seco, no utilice productos químicos o abrasivos.

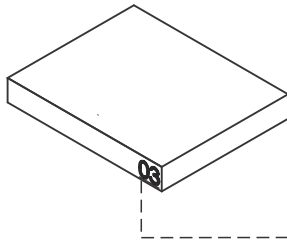

UTILIZE ALCOOL APENAS PARA REMOVER O NUMERO DAS PEÇAS
USE ALCOHOL ONLY TO REMOVE PART NUMBERS
UTILICE ALCOHOL SOLAMENTE PARA ELIMINAR EL NUMERO DE LAS PIEZAS

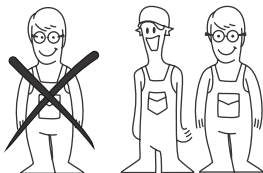

Para facilitar a montagem, utilize uma parafusadeira elétrica.
 To improve assembly, use an eletronic screwdriver.
 Para facilitar el armado, utilice un destornillador eléctrico.

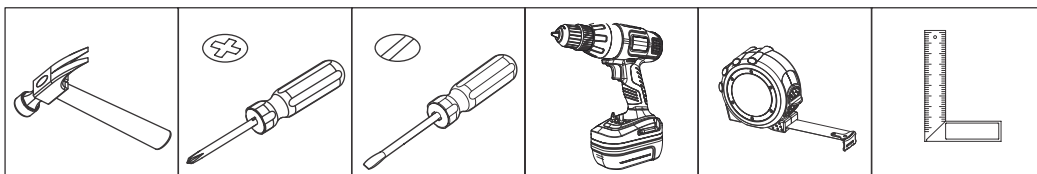

COD BR: BBN 18

PEÇA	DESCRIÇÃO	QUANT.
001	COSTA AÉREO	1
002	TAMPO AÉREO	1
003	LATERAL AÉREO	2
004	PRATELEIRA AÉREO	1
005	BASE AÉREO	1
006	PORTA AÉREO	1
007	TAMPO BALCÃO	1
008	BASE BALCÃO	1
009	LATERAL ESQUERDA BALCÃO	1
010	LATERAL DIREITA BALCÃO	1
011	PRATELEIRA BALCÃO	1
012	PORTA BALCÃO	1
013	COSTA BALCÃO	1

PART	DESCRIPTION	QTY
001	TOP CABINET BAK	1
002	TOP CABINET TOP	1
003	TOP CABINET SIDE	2
004	TOP CABINET SHELF	1
005	TOP CABINET BASE	1
006	TOP CABINET DOOR	1
007	CABINET TOP	1
008	CABINET BASE	1
009	CABINET LEFT SIDE	1
010	CABINET RIGHT SIDE	1
011	CABINET SHELF	1
012	CABINET DOOR	1
013	CABINET BACK	1

PIEZA	DESCRIPCIÓN	CANTIDAD
001	REVÉS AÉREO	1
002	TAPA AÉREO	1
003	LATERAL AÉREO	2
004	REPISA AÉREO	1
005	BASE AÉREO	1
006	PUERTA AÉREO	1
007	TAPA ARMARIO	1
008	BASE ARMARIO	1
009	LATERAL IZQUIERDA ARMARIO	1
010	LATERAL DERECHA ARMARIO	1
011	REPISA ARMARIO	1
012	PUERTA ARMARIO	1
013	REVÉS ARMARIO	1

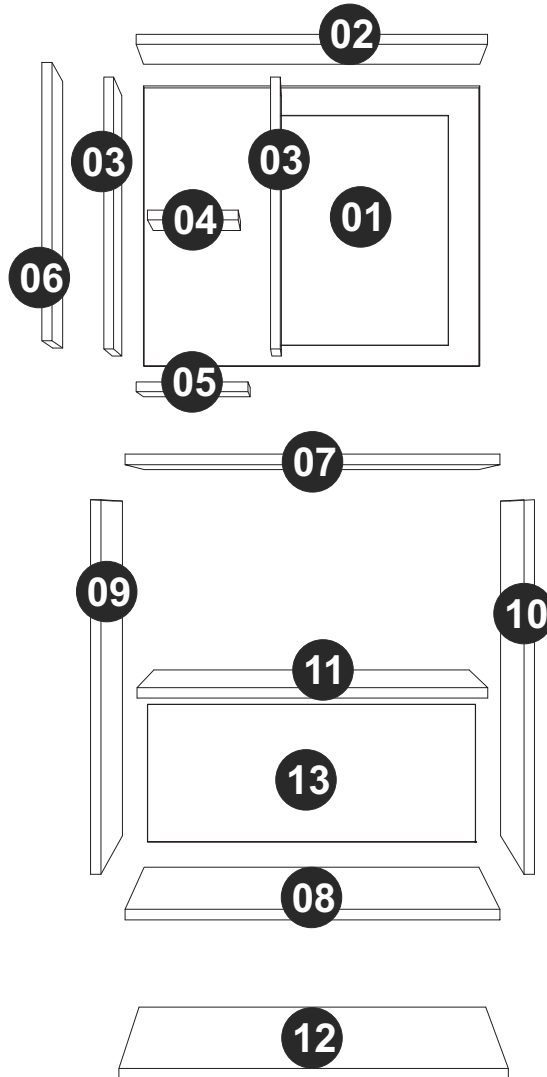



TAPA FUROS x 16
STICKER x 16
TAPAS PLÁSTICAS x 16



EF 000132 x 14
4X50 CC



EF 000106 x 22
3,5X14 CC



EF 000033 x 27
8x30



GIZ x 01
CHALK x 01
TIZA x 01



EF 000216 X 8



EF 000094 X 8



EF 000146 x 6
5X60 CC



CAPA PLASTICA x 2
PLASTIC COVER x 2
CAPA PLASTICA x 2



EF 000016 X 6

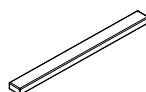

PUXADOR x 2
HANDLE x 2
MANIJA x 2

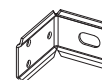

EF 000242 x 2



EF 000025 X 2

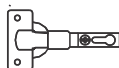

EF 000043 X 2



EF 000381 x 4
3X25 CC

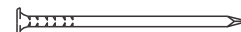

EF 000168 X 18
10X10 C/C



SUPORTE PLÁSTICO x 1
PLASTIC SUPPORT x 1
SOPORTE PLASTICO x 1

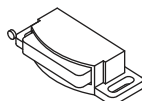

EF 000570 x 1

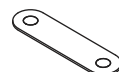

EF 000571 x 1



EF 000732 x 2



ARTICULADOR x 1
ARTICULATOR x1
ARTICULADOR x 1

Utilize para medir as ferragens.

Utilice para medir el herraje.

Use for measuring the hardware.

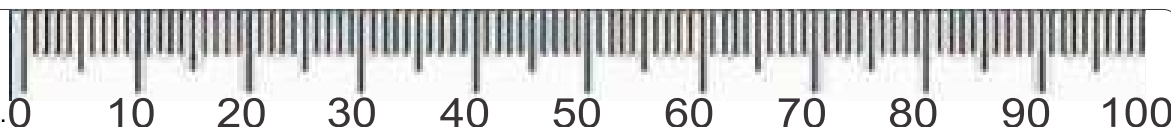

Garantia (exclusivo para o Brasil/exclusivo de Brasil/exclusive to Brazil):

A garantia dos produtos fabricados pela BRV Móveis, abrange eventuais defeitos-vícios de fabricação, no prazo estabelecido pelo código de Defesa do Consumidor, em seu artigo 26.II. o qual prevê a garantia de 90 (noventa) dias.

A = 5KG - 11.02LB

B = 1KG - 2.20LB

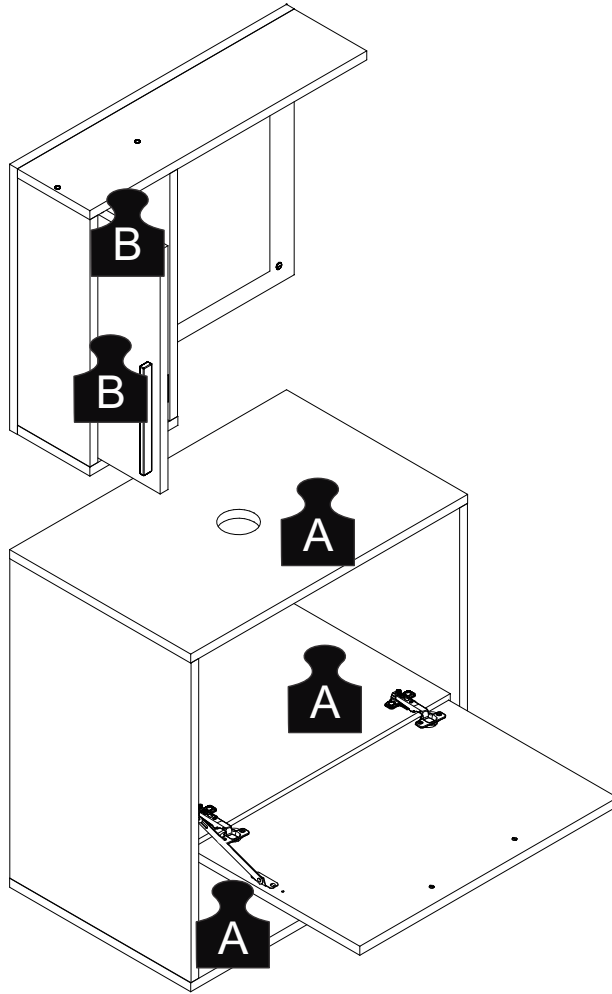

Insira o suporte plástico nas peças 07.
Insert the plastic support into pieces 07.
Añade el soporte plástico en las piezas 07.

PASSO 1 / STEP 1 / PASO 1

Fixe a ferragem EF 000094 nas peças 07, 09 e 10.
Fix hardware EF 000094 in pieces 07, 09 and 10.
Fije el herraje EF 000094 en las piezas 07, 09 y 10.

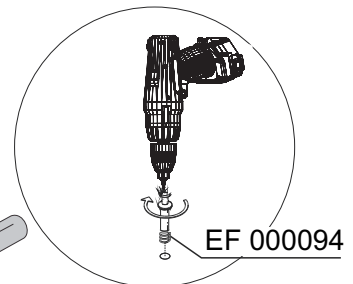
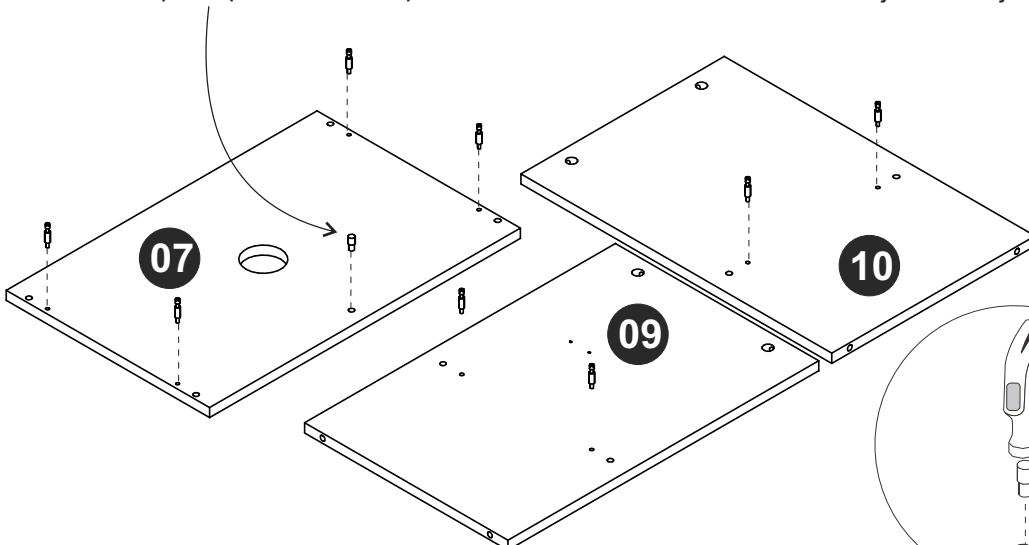

EF 000094

SUPORTE PLÁSTICO
PLASTIC SUPPORT
SOPORTE PLÁSTICO



PASSO 2 / STEP 2 / PASO 2

Insira a ferragem EF 000033 nas peças 02, 03, 04 e 05.
Insert hardware EF 000033 in pieces 02, 03, 04 and 05.
Añade el herraje EF 000033 en las piezas 02, 03, 04 y 05.

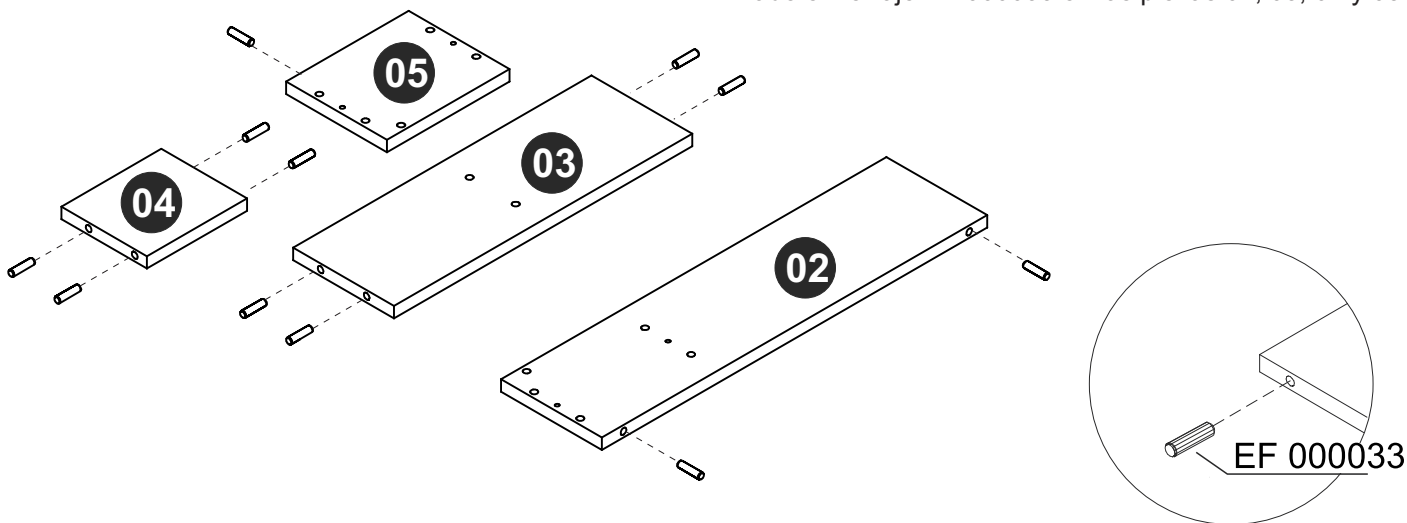

PASSO 3 / STEP 3 / PASO 3

Fixe a ferragem EF 000025 na peça 11 utilizando a ferragem EF 000106. Insira a ferragem EF 000033.
Attach hardware EF 000025 into piece 11 using hardware EF 000106. Insert hardware EF 000033.
Fije el herraje EF 000025 en la pieza 11 utilizando el herraje EF 000106. Añade el herraje EF 000033.

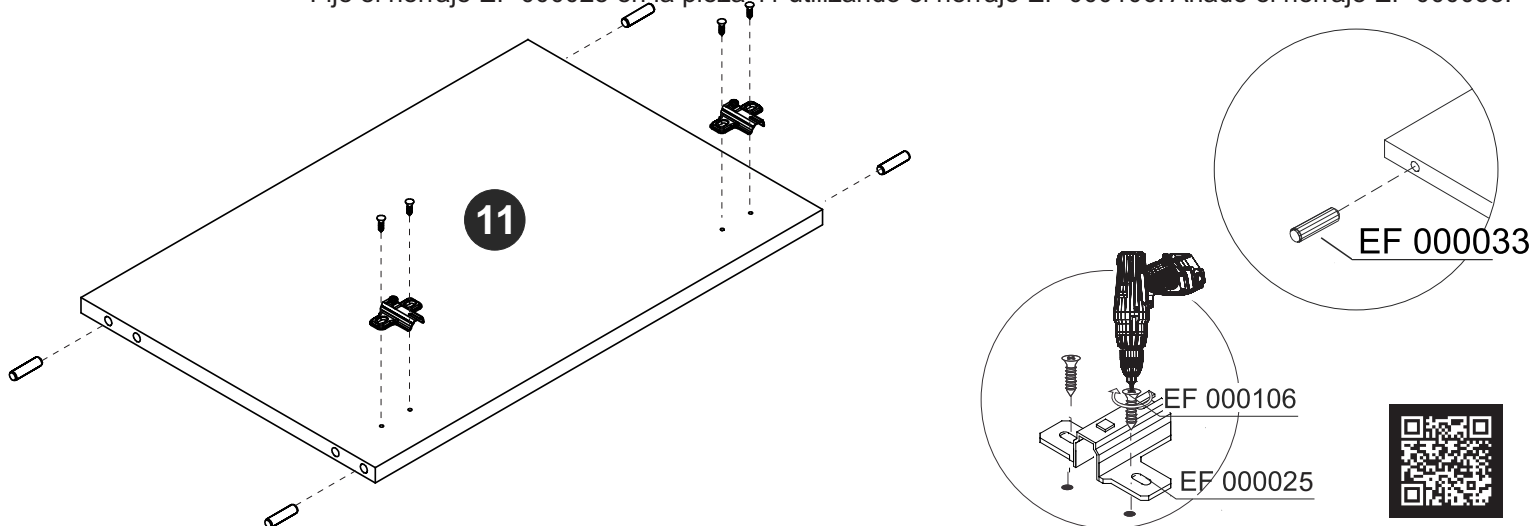

PASSO 4 / STEP 4 / PASO 4

Insira a ferragem EF 000732 na peça 06, fixe o puxador utilizando a ferragem EF 000381.
Fixe a ferragem EF 000571 utilizando a ferragem EF 000106.
Insert hardware EF 000732 into piece 06, attach the handle using hardware EF 000381.
Attach hardware EF 000571 using hardware EF 000106.
Añade el herraje EF 000732 en la pieza 06, fije la manija utilizando el herraje EF 000381.
Fije el herraje EF 000571 using hardware EF 000106.

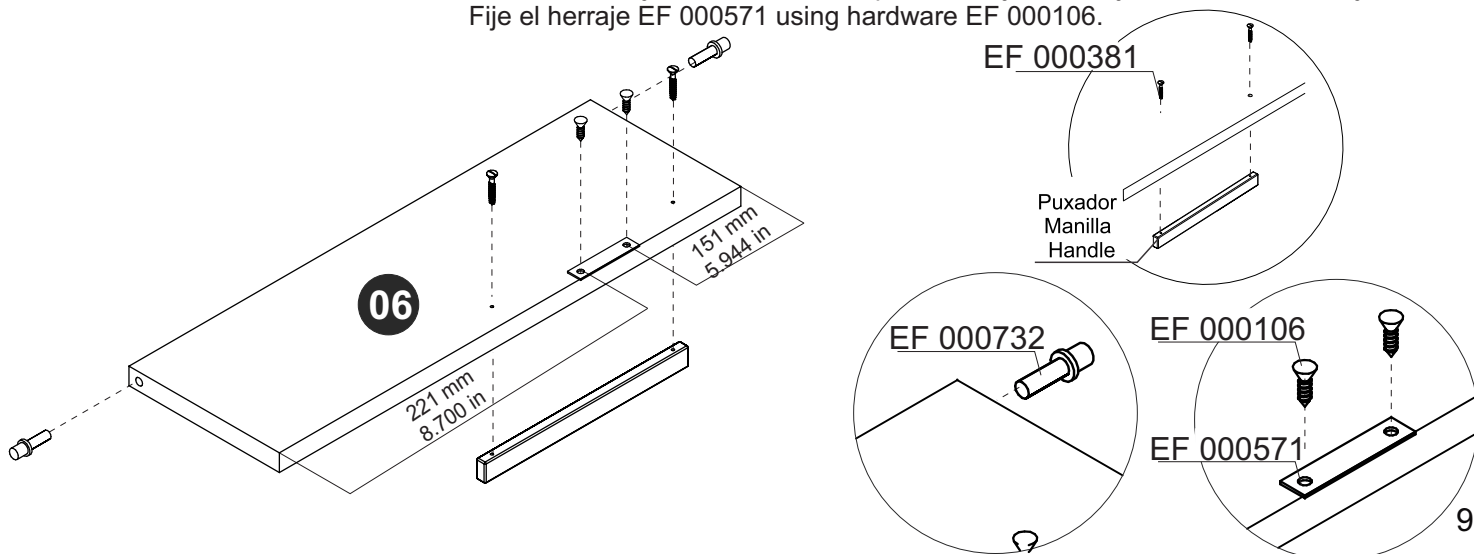

PASSO 5 / STEP 5 / PASO 5

Fixe a ferragem EF 000043 na peça 12 utilizando a ferragem EF 000106.
Fixe o puxador usando a ferragem EF 000404.
Attach hardware EF 000043 on piece 12 using hardware EF 000106. Attach the handle using hardware EF 000404.
Fije el herraje EF 000043 en la pieza 12 utilizando el herraje EF 000106.
Fije la manija utilizando el herraje EF 000404.

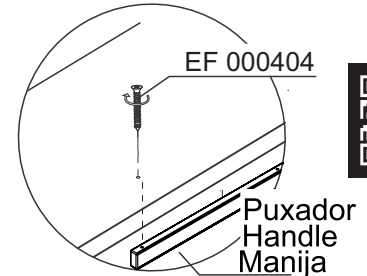
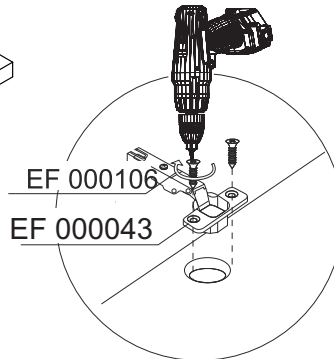
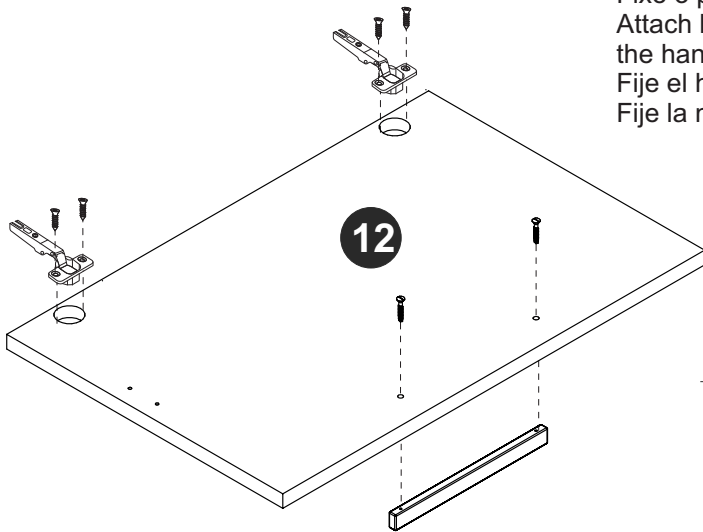

PASSO 6 / STEP 6 / PASO 6

Insira a ferragem EF 000033, use a ferragem EF 000106 para fixar a ferragem EF 000242 nas peças 09 e 10.
Insert hardware EF 000033, use hardware EF 000106 to attach hardware EF 000242 in pieces 09 and 10.
Añade el herraje EF 000033, utilice el herraje EF 000106 para fijar el herraje EF 000242 en las piezas 09 y 10.

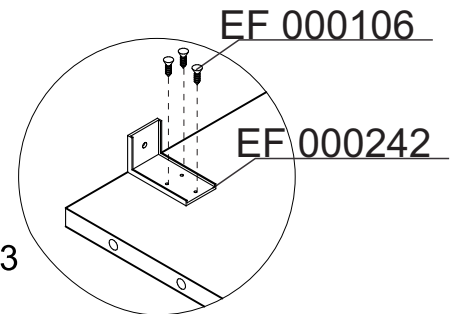
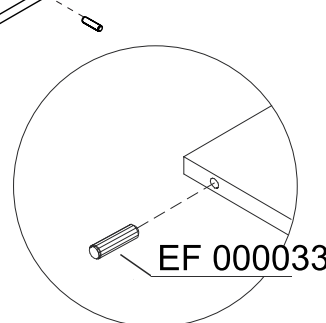
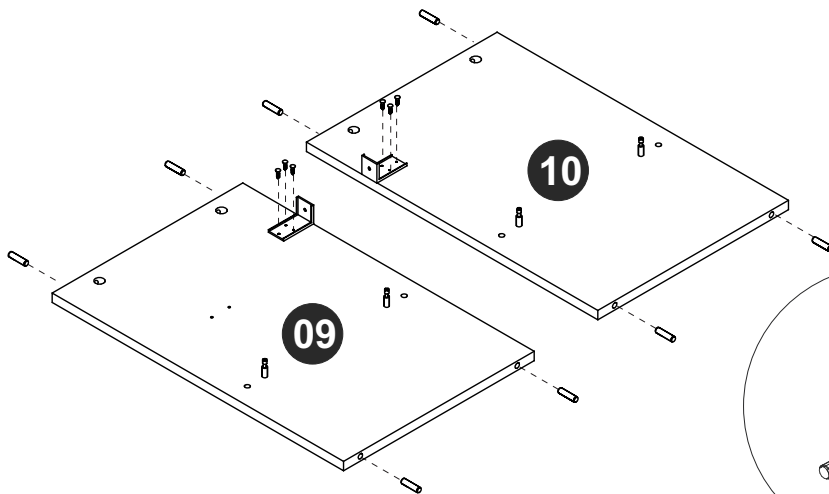

PASSO 7 / STEP 7 / PASO 7

Insira a ferragem EF 000033 na peça 03, fixe a ferragem EF 000570 utilizando a ferragem EF 000106.
Insert hardware EF 000033 into piece 03, attach hardware EF 000571 using hardware EF 000106.
Añade el herraje EF 000033 en la pieza 03, fije el herraje EF 000571 utilizando el herraje EF 000106.

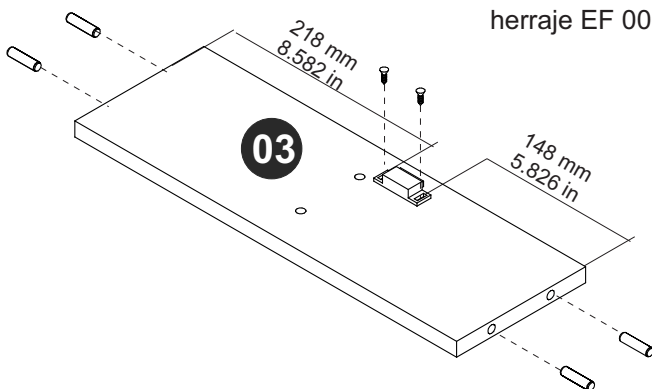

PASSO 8 / STEP 8 / PASO 8

Conecte as peças 09, 10 e 11, insira a ferragem EF 000216 e gire para apertar.
Connect pieces 09, 10 and 11, insert hardware EF 000216 and turn to tighten.
Junte las piezas 09, 10 y 11, añade el herraje EF 000216 y gire para apretar.

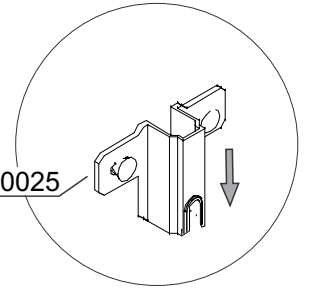
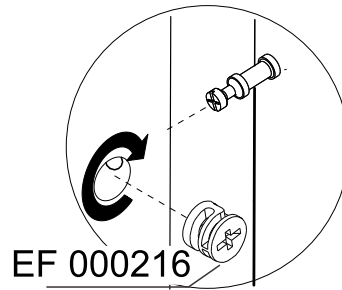
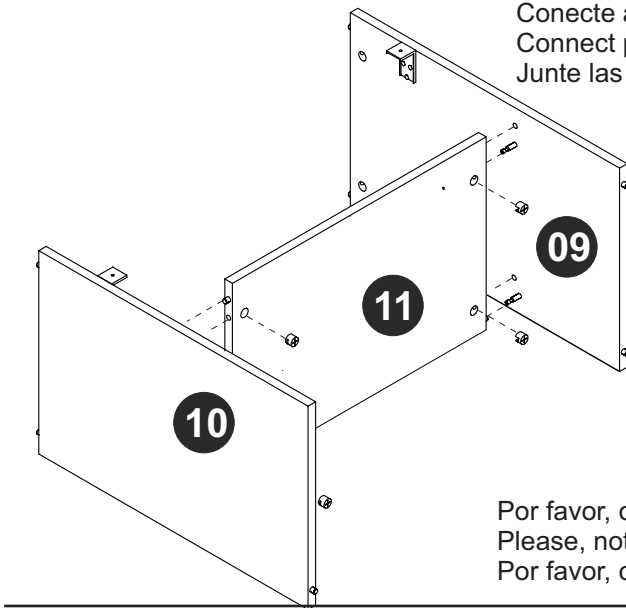

Por favor, observe a posição da ferragem EF 00025.
Please, note hardware EF 00025 position.
Por favor, observe la posición del herraje EF 00025.

PASSO 9 / STEP 9 / PASO 9

Conecte as peças 07, 09 e 10, insira a ferragem EF 000216 e gire para apertar.
Connect pieces 07, 09 and 10, insert hardware EF 000216 and turn to tighten.
Junte las piezas 07, 09 y 10, añade el herraje EF 000216 y gire para apretar.

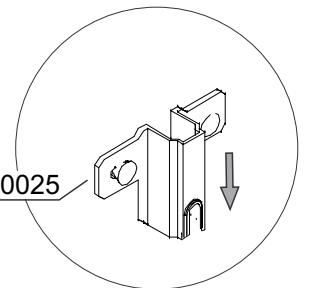
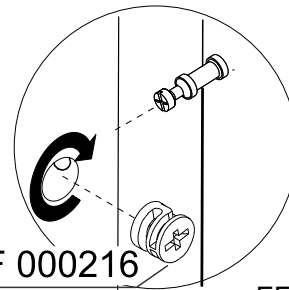
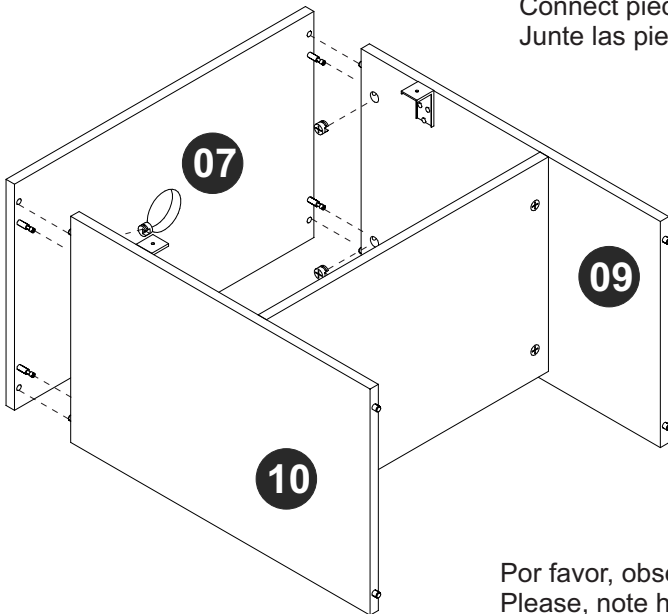

Por favor, observe a posição da ferragem EF 00025.
Please, note hardware EF 00025 position.
Por favor, observe la posición del herraje EF 00025.

PASSO 10 / STEP 10 / PASO 10

Conecte a peça 08 utilizando ferragem EF 000132.
Connect piece 08 using hardware EF 000132.
Junte la pieza 08 utilizando el herraje EF 000132.

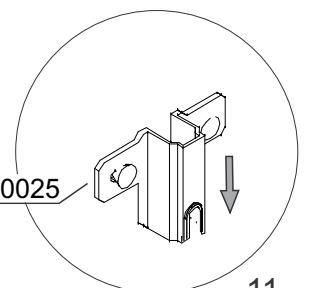
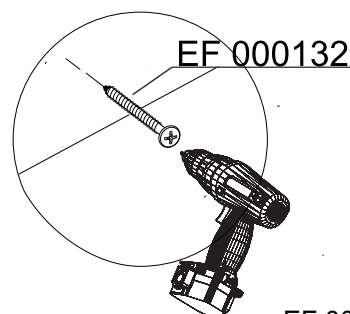
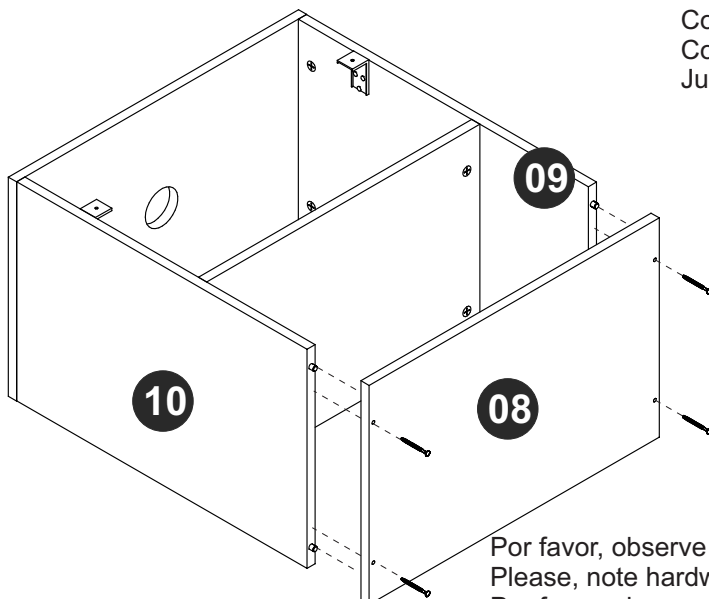

Por favor, observe a posição da ferragem EF 00025.
Please, note hardware EF 00025 position.
Por favor, observe la posición del herraje EF 00025.

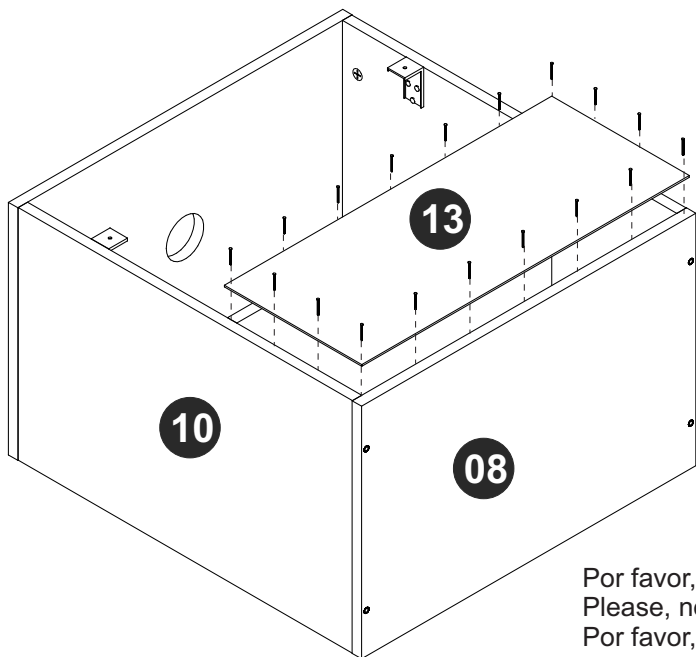

PASSO 11 / STEP 11/ PASO 11

Fixe a peça 13 ao móvel utilizando a ferragem EF 000168.
 Fix piece 13 at the furniture using hardware EF 000168.
 Fije la pieza 13 al mueble utilizando el herraje EF 000168.

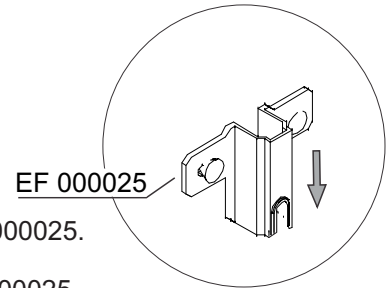
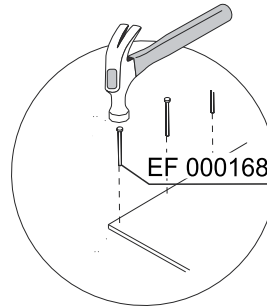

Por favor, observe a posição da ferragem EF 000025.
 Please, note hardware EF 000025 position.
 Por favor, observe la posición del herraje EF 000025.

PASSO 12 / STEP 12 / PASO 12

Conecte a peça 12 ao móvel montado, fixe o articulador utilizando a ferragem EF 000106.
 Connect piece 12 to the assembled furniture, attach the articulator using hardware EF 000106.
 Junte la pieza 12 al mueble armado, fije el articulador utilizando el herraje EF 000106.

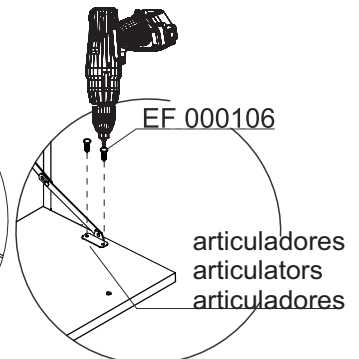
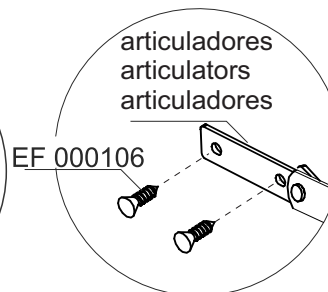
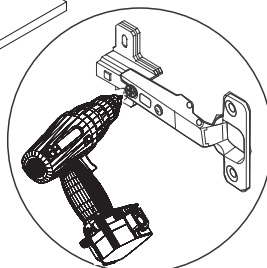
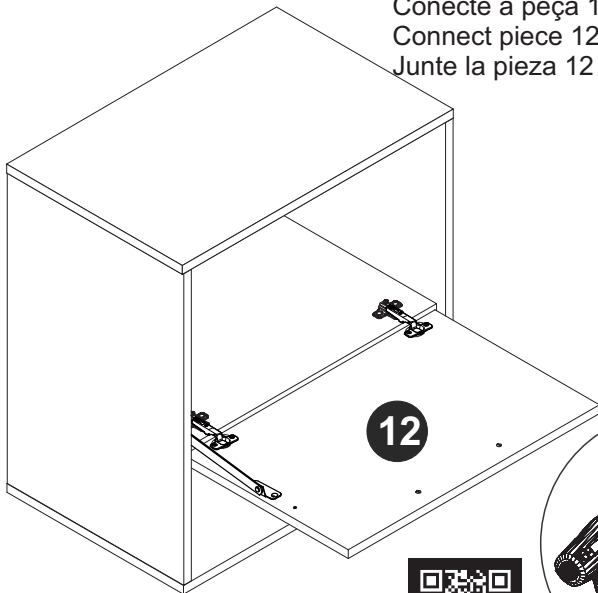

PASSO 13 / STEP 13 / PASO 13

Encaixe as peças 03 e 04.
 Fit pieces 03 and 04.
 Junte las piezas 03 y 04.

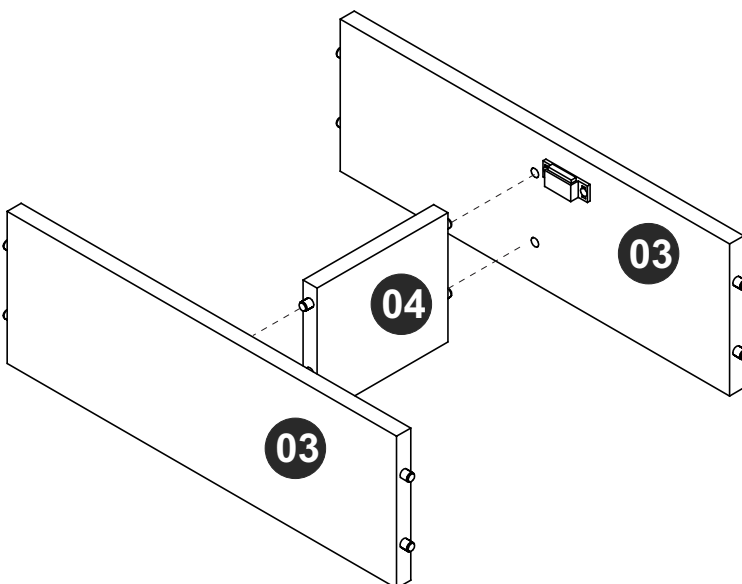

PASSO 14 / STEP 14/ PASO 14

Encaixe a peça 06, fixe as peças 02 e 05 utilizando a ferragem EF 000132.
Fit piece 06, attach pieces 02 and 05 using hardware EF 000132.
Junte la pieza 06, fije las piezas 02 y 05 utilizando el herraje EF 000132..

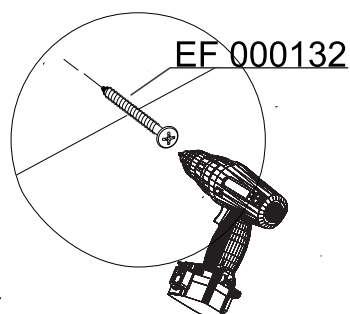
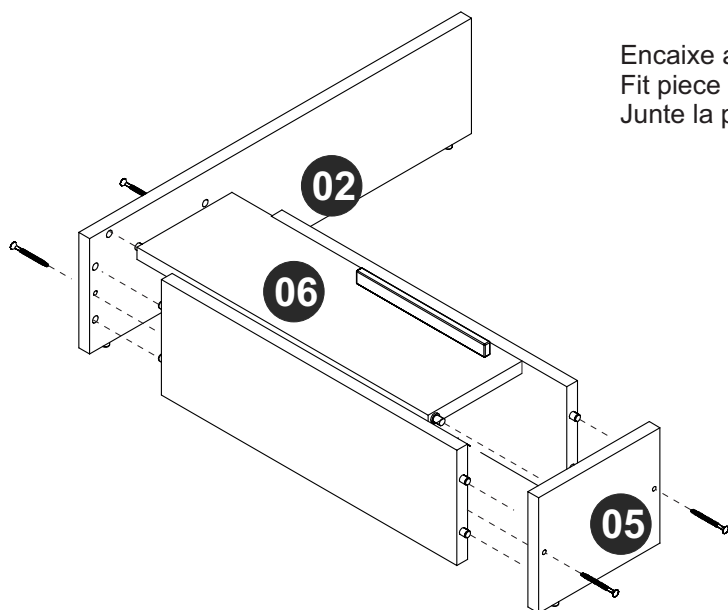

PASSO 15 / STEP 15 / PASO 15

Conecte a peça 01 utilizando ferragem EF 000132.
Connect piece 01 using hardware EF 000132.
Junte la pieza 01 utilizando el herraje EF 000132.

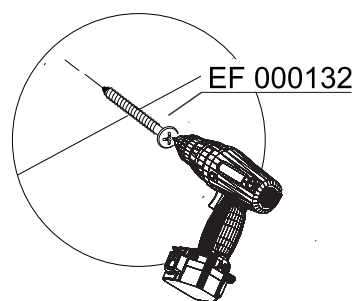
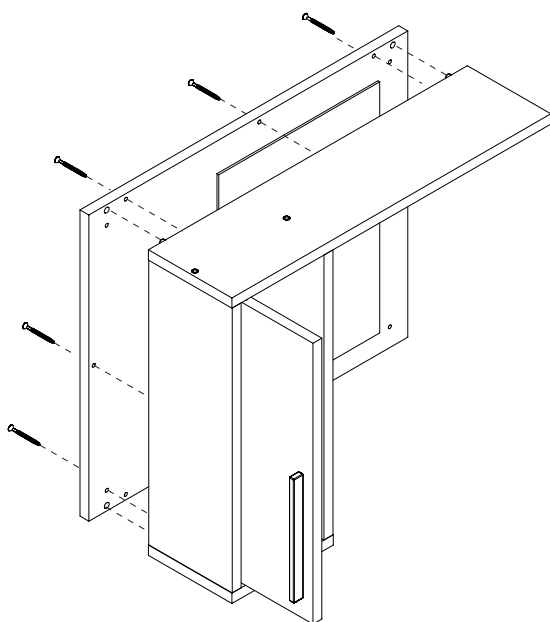

PASSO 16 / STEP 16 / PASO 16

Perfure a parede e insira a ferragem EF 000016. Fixe o móvel na parede utilizando a ferragem EF 000146 e encaixe a capa plastica.
Drill the wall and insert hardware EF 000016. Attach the furniture on the wall using hardware EF 000146 and fit the plastic cover.
Perfore la pared y añade el herraje EF 000016. Fije el mueble en la pared utilizando el herraje EF 000146 y añade la capa plastica.

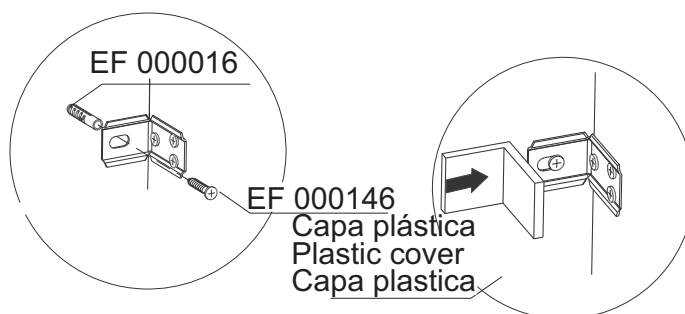
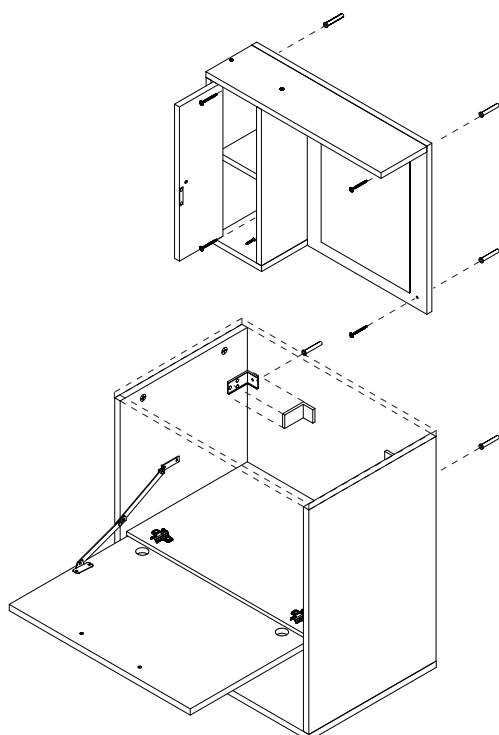

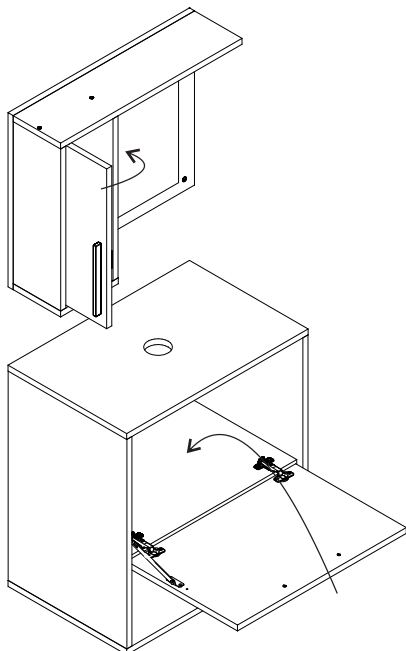

PASSO 17 / STEP 17 / PASO 17

Utilize o tapa furos para cobrir os parafusos aparentes.
Use the sticker to cover the apparent screws.
Utilice los tapa huecos para cubrir los tornillos aparentes.

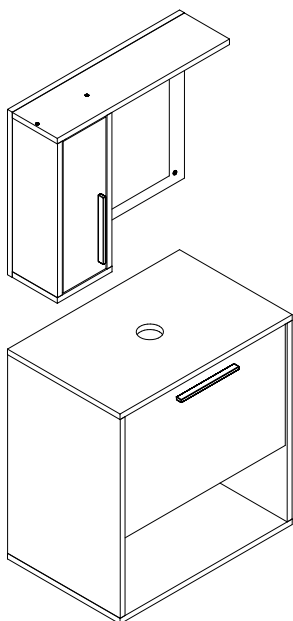
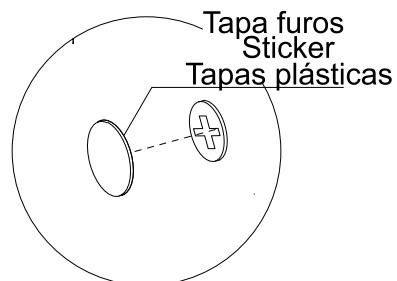

PASSO 18 / STEP 18 / PASO 18

Utilize o giz para dar o acabamento final ao produto.
Use the chalk to give the final finish on the product.
Utilize la tiza para dar el acabado final al producto.

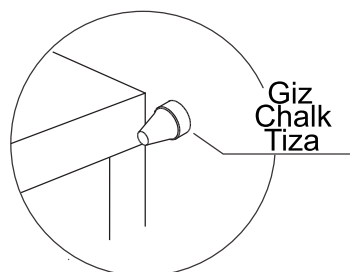

PASSO 19 / STEP 19 / PASO 19

