



MANUAL DE MONTAGEM  
ASSEMBLY INSTRUCTIONS  
INSTRUCCIONES DE MONTAJE

COD BR: BR 399



# Sumário Summary Resumen

Introdução Introduction Introducción	.....	3
Antes de começar Before starting Antes de comenzar	.....	4
Evite acidentes Avoid accidents Evitar accidentes	.....	4
Dimensões e ferramentas Dimensions and tools Dimensiones y herramientas	.....	5
Identificação das peças Identifying parts Identificación de las piezas	.....	6
Acessórios incluídos na caixa Hardware included in box Accesorios incluidos en la caja	.....	7
Montagem do móvel Furniture assembly Montaje del mueble	.....	8

## Introdução Introduction Introducción

Leia atentamente este manual e siga os passos indicados para que o produto não perca a garantia e também para uma perfeita montagem.

Read this manual and follow the steps in order to keep the guarantee and also for the perfect fit.

Lea este manual y siga los pasos para que el producto no pierda la garantía y también para el ajuste perfecto.

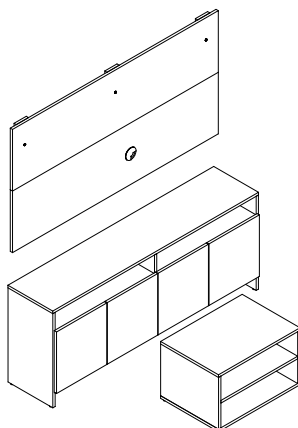

## Antes de começar Before starting Antes de comenzar

Antes de começar a montagem prepare o ambiente, deixando-o completamente limpo e com bom espaço para iniciar o trabalho.

Prepare the room before starting the assembly, leaving it completely clean and the area in good condition to start the work.

Antes de comenzar el montaje preparar el ambiente, dejándolo completamente limpio y con bueno espacio para comenzar el trabajo.

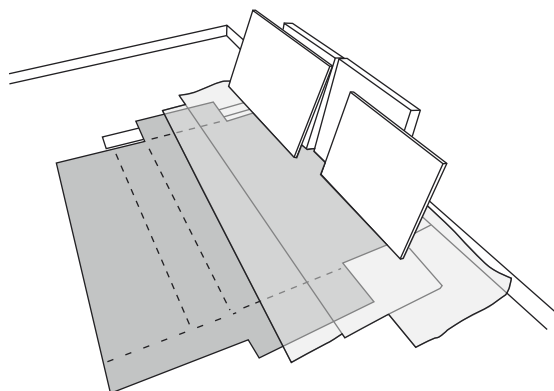

Utilize o papelão da própria embalagem para separar e apoiar as peças retiradas das caixas.

Use the cardboard of the packaging to separate and support the parts removed from the boxes.

Utilice el cartón de la embalaje para separar y apoyar las piezas desmontadas de las cajas.



Forre a área de montagem com um cobertor ou tapete. Assim, você evita avarias nas peças durante o processo de montagem.

Cover the assembly area with a blanket or carpet to avoid damaging the parts during the assembly process.

Cubrir la zona de ensamble con una manta o alfombra. De este modo, se evitan daños en las piezas durante el proceso de montaje.



## Evite acidentes Avoid accidents Prevenir accidentes

Solicitamos observar atentamente as orientações de montagem como: fixação do produto na parede, colocação de cola em locais específicos necessários, o peso suportado pelo produto, etc...

We request you to carefully observe the assembly instructions as: fixing the product on the wall, adding glue in needed and specific places, product weight limit, etc.

Pedimos que lea atentamente las instrucciones, principalmente las informaciones de fijación del producto en la pared, colocación de pegamento en local específico y necesario, el peso soportado por el producto etc...

Não escale ou se apoie no móvel.

Do not climb or lean on the furniture.

No se suba ni se apoye en el mueble.

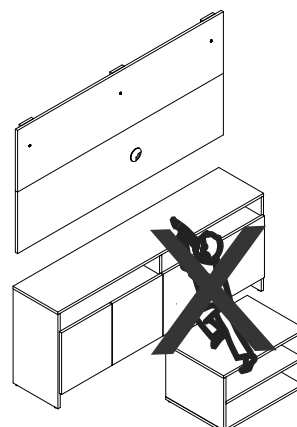

Dimensões e ferramentas  
 Dimensions and tools  
 Dimensiones y herramientas

Painel / TV Panel

Dimensões:

L: 1350 A: 700 P: 30 mm

Dimensions:

W: 53.14 H: 27.55 D: 1.18 inches

Dimensiones:

L: 1350 A: 700 P: 30 mm

Rack / TV Stand

Dimensões:

L: 1350 A: 555 P: 294 mm

Dimensions:

W: 53.14 H: 21.85 D: 11.57 inches

Dimensiones:

L: 1350 A: 555 P: 309 mm

Mesa de centro / Center table

Dimensões:

L: 535 A: 329 P: 380 mm

Dimensions:

W: 21.06 H: 12.95 D: 14.96 inches

Dimensiones:

L: 535 A: 329 P: 380 mm

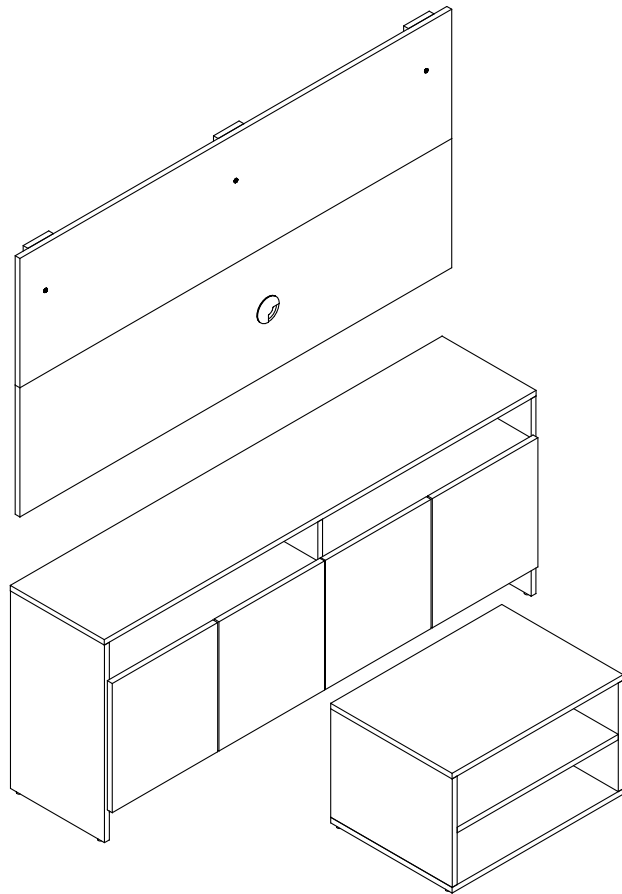

Limpeza  
 Cleanig  
 Limpieza

Pano levemente umedecido com água, seguido de pano seco, não utilizar produtos químico ou abrasivos.  
 Slightly dampened cloth and after a dry cloth, do not use chemicals or abrasives.  
 Solamente utilizar un paño húmedo y después un paño seco, no utilice productos químicos o abrasivos.

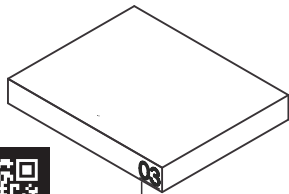

**UTILIZE ALCOOL APENAS PARA REMOVER O NUMERO DAS PEÇAS**  
**USE ALCOHOL ONLY TO REMOVE PART NUMBERS**  
**UTILICE ALCOHOL SOLAMENTE PARA ELIMINAR EL NUMERO DE LAS PIEZAS**

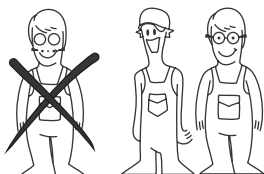

Para facilitar a montagem, utilize uma parafusadeira elétrica.  
 To improve assembly, use an eletronic screwdriver.  
 Para facilitar el armado, utilice un destornillador eléctrico.

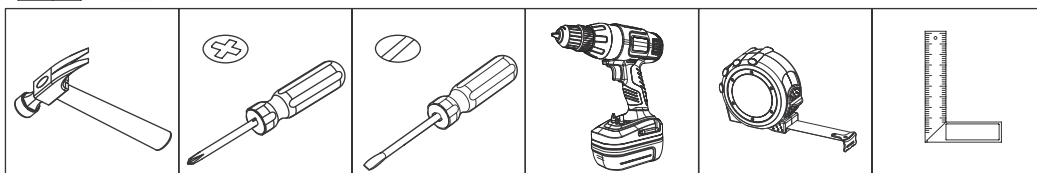

## COD BR: BR 399

PEÇA	DESCRIÇÃO	QUANT.
001	BASE RACK	1
002	TAMPO RACK	1
003	TRAVESSA PAINEL	1
004	LATERAL DIREITA RACK	1
005	DIVISÓRIA RACK	1
006	PRATELEIRA RACK	2
007	PORTA	4
008	BASE MESA DE CENTRO	1
009	PAINEL TV INFERIOR	1
010	PAINEL TV SUPERIOR	1
011	LATERAL ESQUERDA	1
012	TAMPO MESA DE CENTRO	1
013	LATERAL MESA DE CENTRO	2
014	PRATELEIRA MESA DE CENTRO	1
015	COSTAS	1

PART	DESCRIPTION	QTY
001	TV STAND BASE	1
002	TV STAND LEFT TOP	1
003	TV PANEL TRAVERSE	1
004	TV STAND RIGHT SIDE	1
005	TV STAND PARTITION	1
006	TV STAND SHELF	2
007	DOOR	4
008	CENTER TABLE BASE	1
009	LOWER TV PANEL	1
010	UPPER TV PANEL	1
011	TV STAND LEFT SIDE	1
012	CENTER TABLE TOP	1
013	CENTER TABLE SIDE	2
014	SHELF TABLE SIDE	1
015	TV STAND BACK	1

PIEZA	DESCRIPCIÓN	CANTIDAD
001	BASE RACK	1
002	TAPA RACK	1
003	TRAVESAÑO PANEL TV	1
004	LATERAL DERECHA RACK	1
005	PARTICIÓN RACK	1
006	REPISA RACK	2
007	PUERTA	4
008	BASE MESA DE CENTRO	1
009	PANEL TV INFERIOR	1
010	PANEL TV SUPERIOR	1
011	LATERAL IZQUIERDA RACK	1
012	TAPA MESA DE CENTRO	1
013	LATERAL MESA DE CENTRO	2
014	REPISA MESA DE CENTRO	1
015	REVÉS RACK	1

PAINEL / TV PANEL

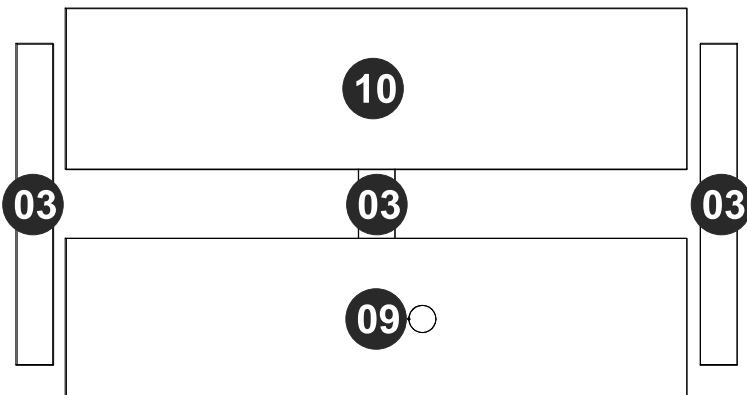

RACK / TV STAND

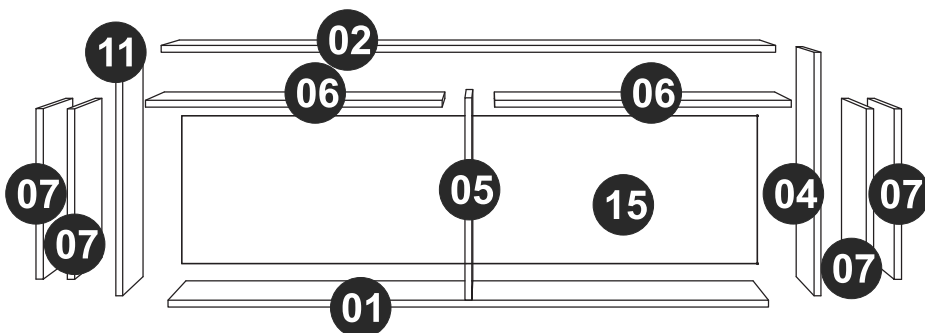

MESA DE CENTRO / CENTER TABLE

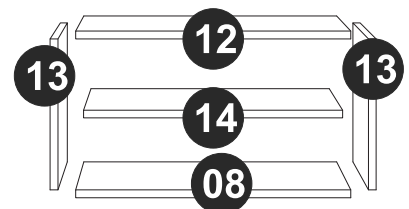

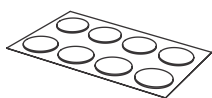

TAPA FUROS x 29  
STICKER x 29  
TAPAS PLÁSTICAS x 29



EF 000106 x 24  
3,5X14 CC



EF 000216 X 26



EF 000033 x 28  
8x30



EF 000094 X 22



EF 000132 x 6  
4X50 CC

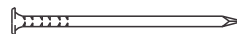

EF 000168 X 44  
10X10 C/C



GIZ x 1  
CHALK x 1  
TIZA x 1



PÉS REDONDOS x 8  
ROUND FEET x 8  
PIES REDONDOS x 8

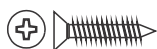

EF 000404 x 12  
3,5X25 CC

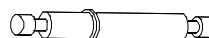

EF 000067 x 2



EF 000241x 12  
8x20



EF 000015 X 3



PASSA - FIO x 1  
PASS - WIRE x 1  
PASA - CABLE x 1



EF 000731 x 2  
8x55



EF 000250 x 3  
5X80 CC



EF 000024 X 8

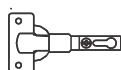

EF 000044 X 8



EF 000091 x 8  
6x8 CC

Utilize para medir as ferragens.

Utilice para medir el herraje.

Use for measuring the hardware.

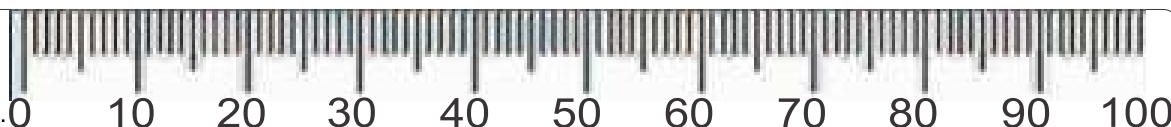

**Garantia (exclusivo para o Brasil/exclusivo de Brasil/exclusive to Brazil):**

A garantia dos produtos fabricados pela BRV Móveis, abrange eventuais defeitos-vícios de fabricação, no prazo estabelecido pelo código de Defesa do Consumidor, em seu artigo 26.II. o qual prevê a garantia de 90 (noventa) dias.

**A** = 14KG - 30.86LB

**B** = 6KG - 13.22LB

48"

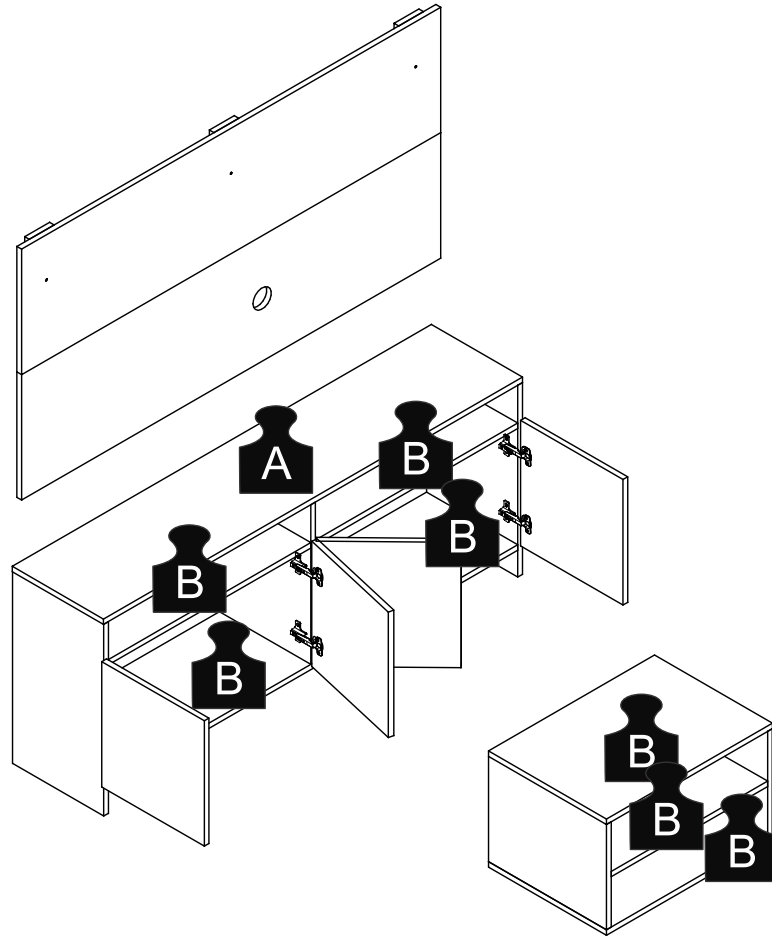

**PASSO 1 / STEP 1 / PASO 1**

Insira a ferragem EF 000094 nas peças 02, 04, 11, 12 e 13.  
Insert hardware EF 000094 into pieces 02, 04, 11, 12 and 13.  
Añade el herraje EF 000094 en las piezas 02, 04, 11, 12 y 13.

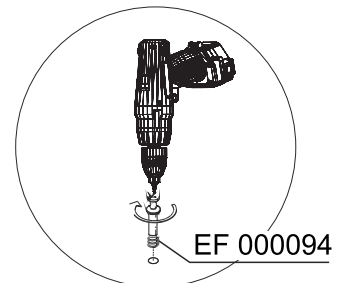
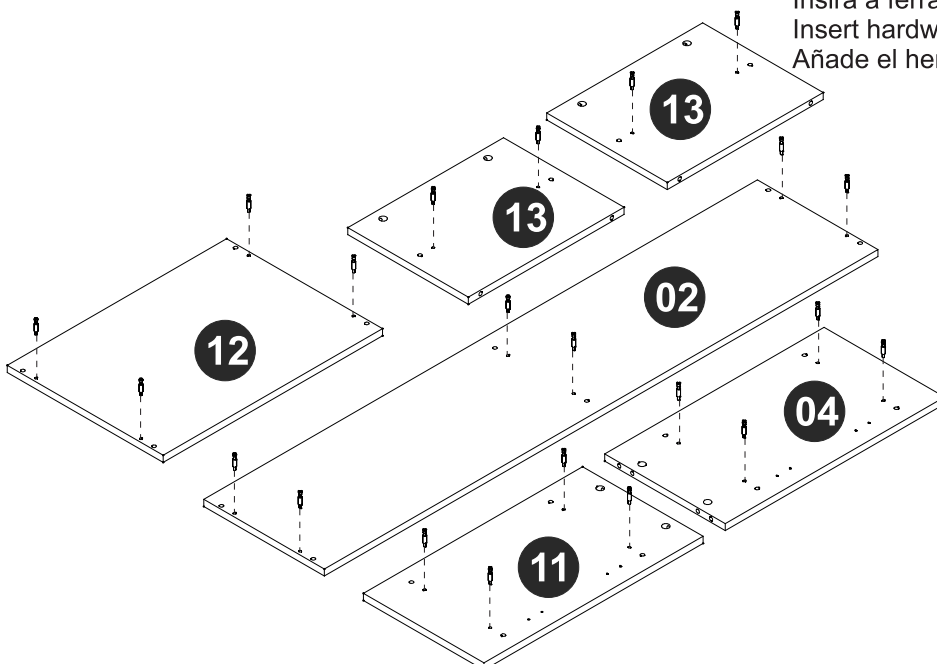



## PASSO 2 / STEP 2 / PASO 2

Insira a ferragem EF 000033 nas peças 01, 04, 05, 06, 11, 13 e 14.  
Insert hardware EF 000033 into pieces 01, 04, 05, 06, 11, 13 and 14.  
Añade herraje EF 000033 en las piezas 01, 04, 05, 06, 11, 13 y 14.

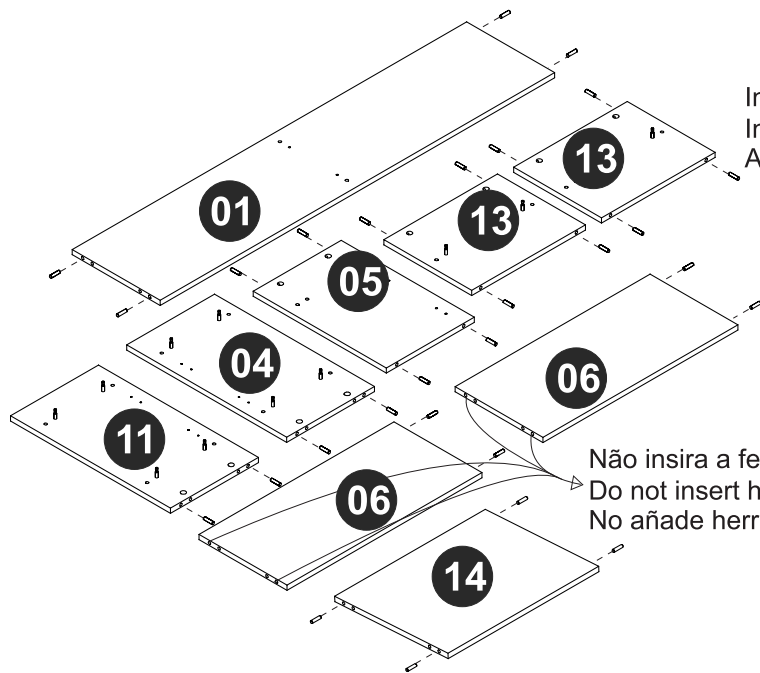

Não insira a ferragem EF 000033 aqui.  
Do not insert hardware EF 000033 here.  
No añade herraje EF 000033 aquí.

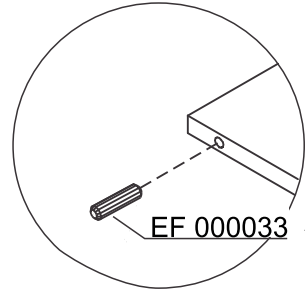

## PASSO 3 / STEP 3 / PASO 3

Fixe a ferragem EF 000024 nas peças 04 e 11 utilizando a ferragem EF 000106.  
Fixe a ferragem EF 000024 na peça 05 utilizando a ferragem EF 000091.  
Attach hardware EF 000024 at pieces 04 and 11 using hardware EF 000106.  
Attach hardware EF 000024 at piece 05 using hardware EF 000091.  
Fije el herraje EF 000024 en las piezas 04 y 11 utilizando el herraje EF 000106.  
Fije el herraje EF 000024 en la pieza 05 utilizando el herraje EF 000091.

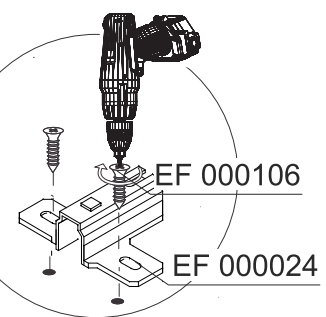
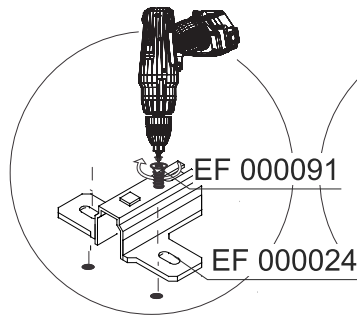
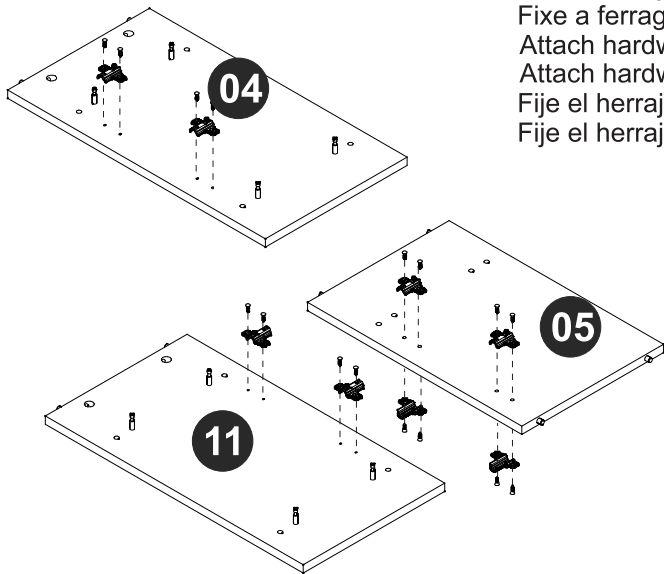

## PASSO 4 / STEP 4 / PASO 4

Fixe a ferragem EF 000044 usando a ferragem EF 000106.  
Fix hardware EF 000044 using hardware EF 000106.  
Fije el herraje EF 000044 utilizando el herraje EF 000106.

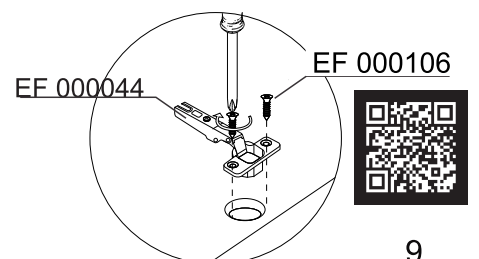
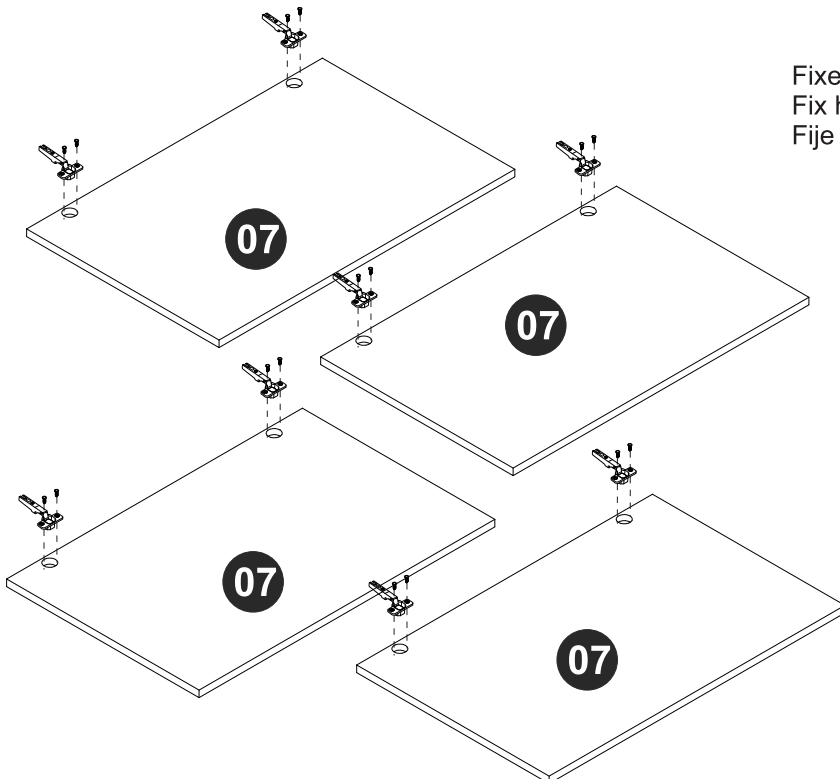

### PASSO 5 / STEP 5 / PASO 5

Insira a ferragem EF 000241 nas peças 03.  
Insert hardware EF 000241 into pieces 03.  
Añade el herraje EF 000241 en las piezas 03.

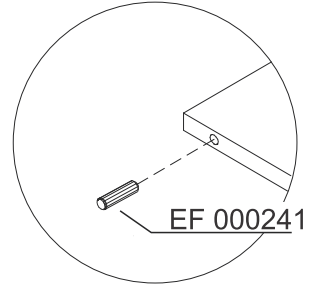
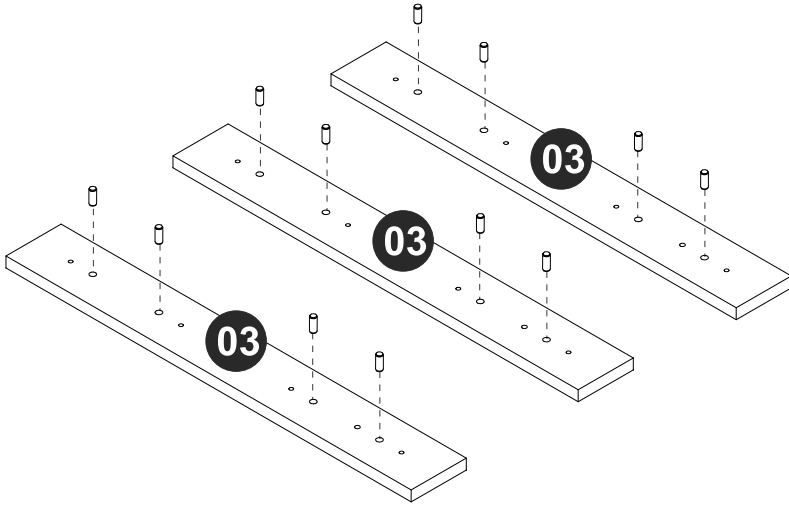

Junte as peças 01, 02 e 03 utilizando a ferragem EF 000404.  
Join pieces 01, 02 and 03 using hardware EF 000404.  
Junte las piezas 01, 02 y 03 utilizando el herraje EF 000404.

### PASSO 6 / STEP 6 / PASO 6

Fixe as peças 03, 09 e 10 utilizando a ferragem EF 000404.  
Attach pieces 03, 09 and 10 using hardware EF 000404.  
Fije las piezas 03, 09 y 10 utilizando el herraje EF 000404.

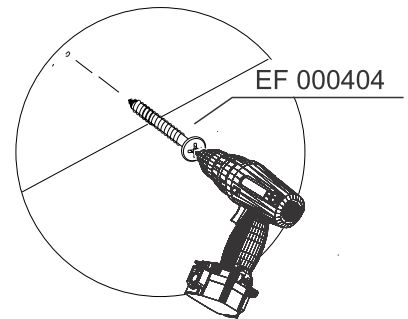
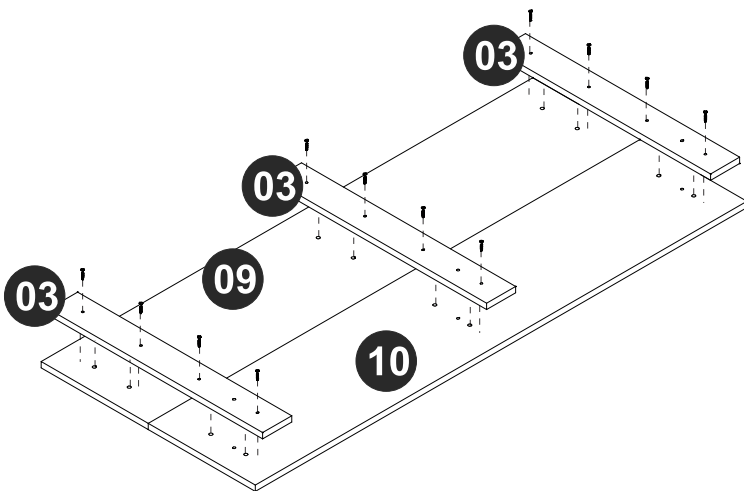

### PASSO 7 / STEP 7 / PASO 7

Utilize as ferragens EF 000015 e EF 000250 para fixar o painel na parede.  
Insira o passa-fio.  
Use hardwares EF 000015 and EF 000250 to fix the panel on the wall.  
Insert the pass-wire.  
Utilice los herrajes EF 000015 y EF 000250 para fijar el panel en la pared.  
Añade el pasa-cable.

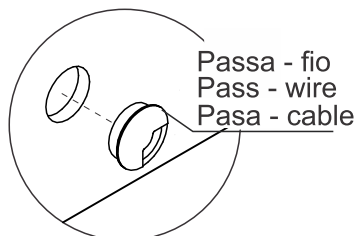
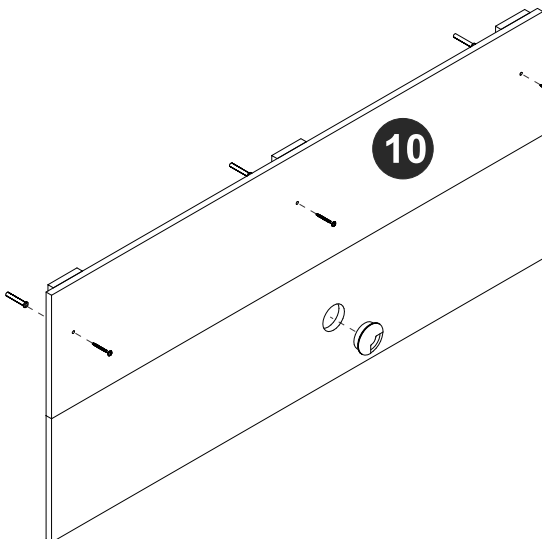

EF 000250.

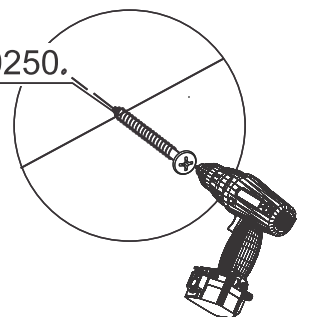

### PASSO 8 / STEP 8 / PASO 8

Utilize as ferragens EF 000015 e EF 000250 para fixar o painel na parede.  
Insira o passa-fio.  
Use hardware EF 000015 and EF 000250 to fix the panel on the wall.  
Insert the pass-wire.  
Utilice los herrajes EF 000015 y EF 000250 para fijar el panel en la pared.  
Añade el pasa-cable.

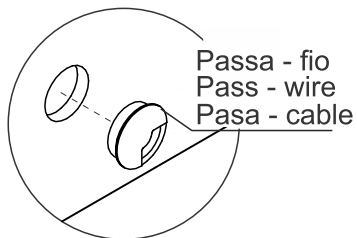
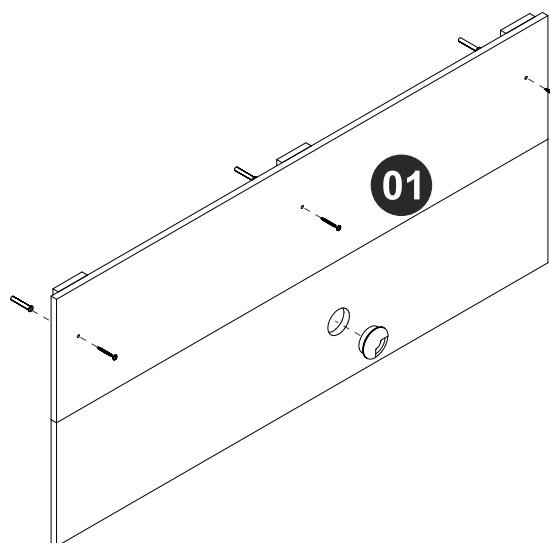

EF 000250.

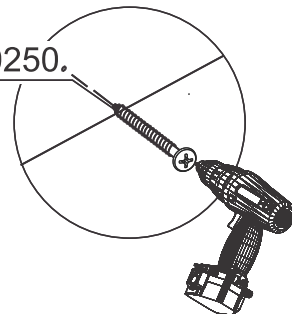

### PASSO 9 / STEP 9 / PASO 9

Conecte as peças 13 e 14, insira a ferragem EF 000216 e gire para apertar.  
Connect pieces 13 and 14, insert hardware EF 000216 and turn to tighten.  
Junte las piezas 13 y 14, añade el herraje EF 000216 y gire para apretar.

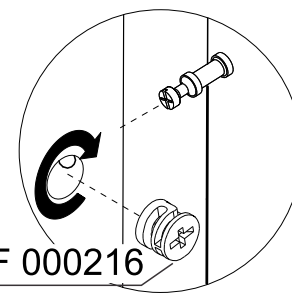
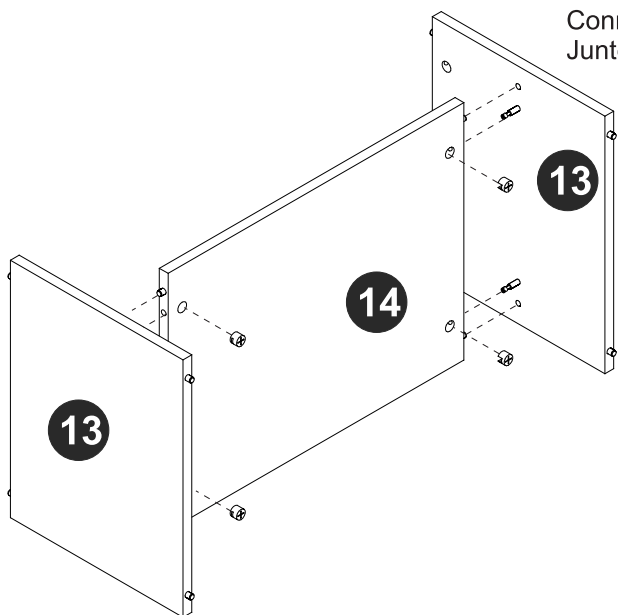

EF 000216

### PASSO 10 / STEP 10 / PASO 10

Conecte a peça 12, insira a ferragem EF 000216 e gire para apertar.  
Connect piece 12, insert hardware EF 000216 and turn to tighten.  
Junte la pieza 12, añade el herraje EF 000216 y gire para apretar.

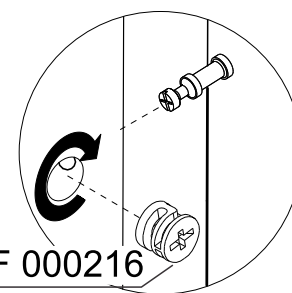
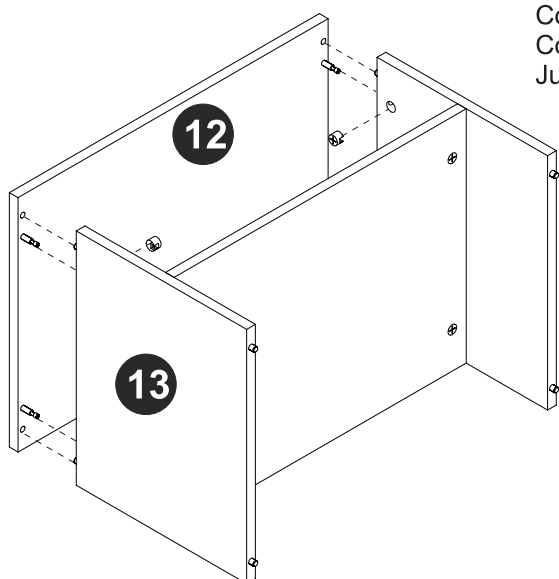

EF 000216

### PASSO 11 / STEP 11 / PASO 11

Conecte a peça 08 utilizando a ferragem EF 000132.  
Connect piece 08 using hardware EF 000132.  
Junte la pieza 08 utilizando el herraje EF 000132.

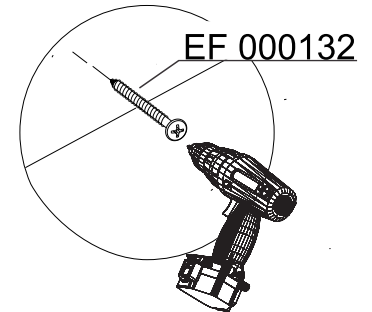
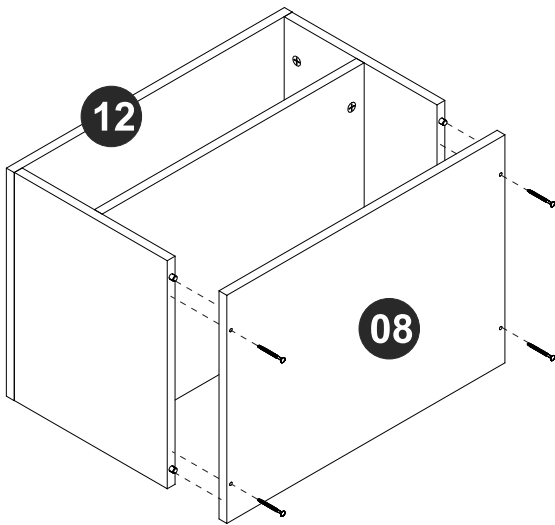

### PASSO 12 / STEP 12 / PASO 12

Fixe os pés utilizando a ferragem EF 000168.  
Attach the feet using hardware EF 000168.  
Fije los pies utilizando el herraje EF 000168.

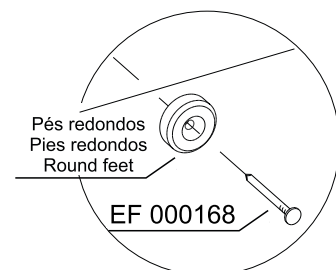
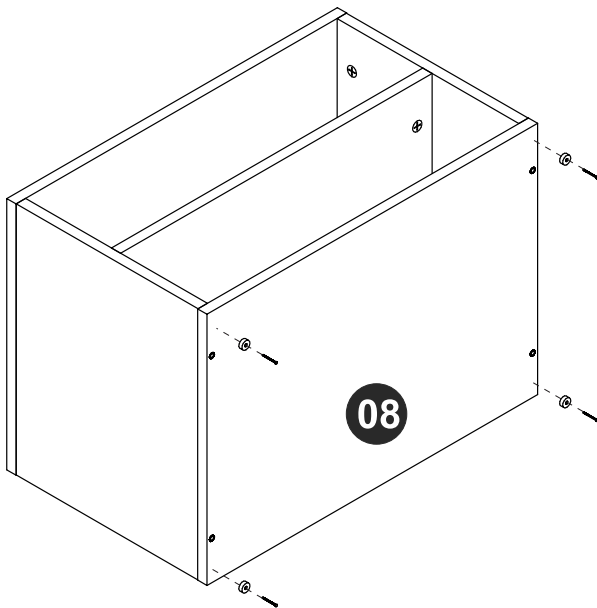

### PASSO 13 / STEP 13 / PASO 13

Conecte as peças 01 e 05 utilizando a ferragem EF 000132.  
Connect pieces 01 and 05 using hardware EF 000132.  
Junte las piezas 01 y 05 utilizando el herraje EF 000132.

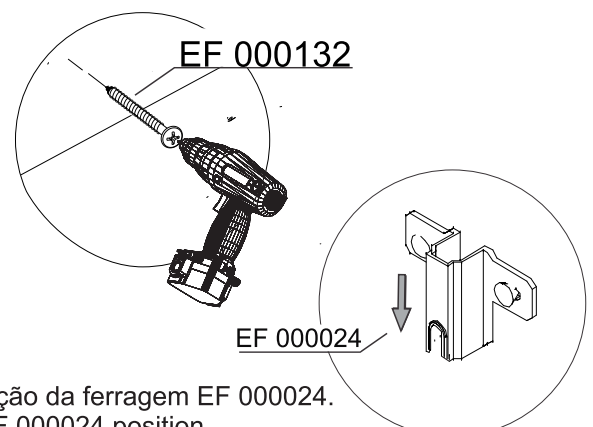
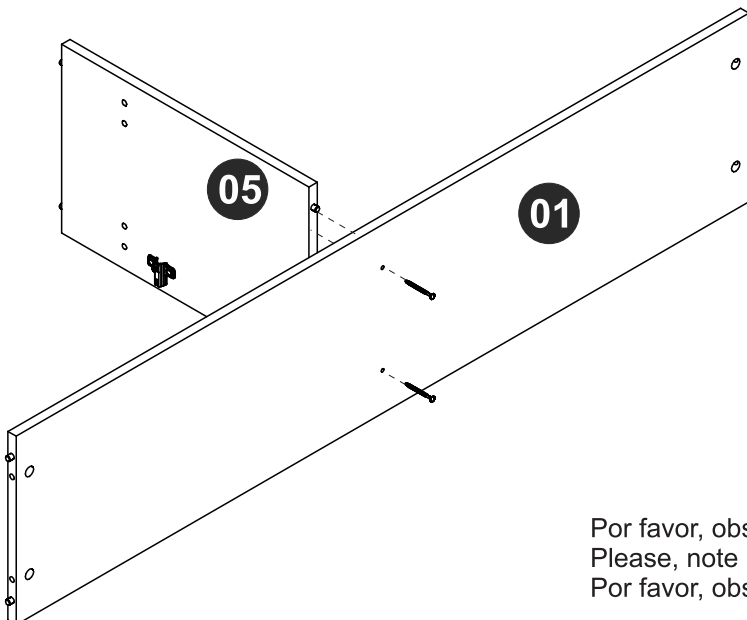

Por favor, observe a posição da ferragem EF 000024.  
Please, note hardware EF 000024 position.  
Por favor, observe la posición del herraje EF000024.

### PASSO 14 / STEP 14/ PASO 14

Use as ferragens EF 000067 e EF 000731 para conectar as peças 05 e 06. Insira a ferragem EF 000216 e gire para apertar.  
Use hardware EF 000067 and EF 000731 to connect pieces 05 and 06. Insert hardware EF 000216 and turn to tighten.  
Utilice los herrajes EF 000067 y EF 000731 para juntar las piezas 05 y 06. Añade el herraje EF 000216 y gire para apretar.

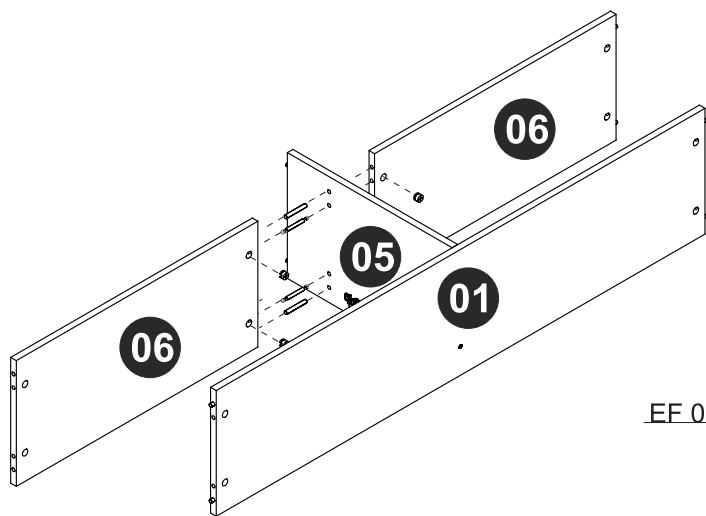

EF 000067

EF 000731

EF 000216

### PASSO 15 / STEP 15 / PASO 15

Conecte as peças 04 e 11, insira a ferragem EF 000216 e gire para apertar.  
Connect pieces 04 and 11, insert hardware EF 000216 and turn to tighten.  
Junte las piezas 04 y 11, añade el herraje EF 000216 y gire para apretar.

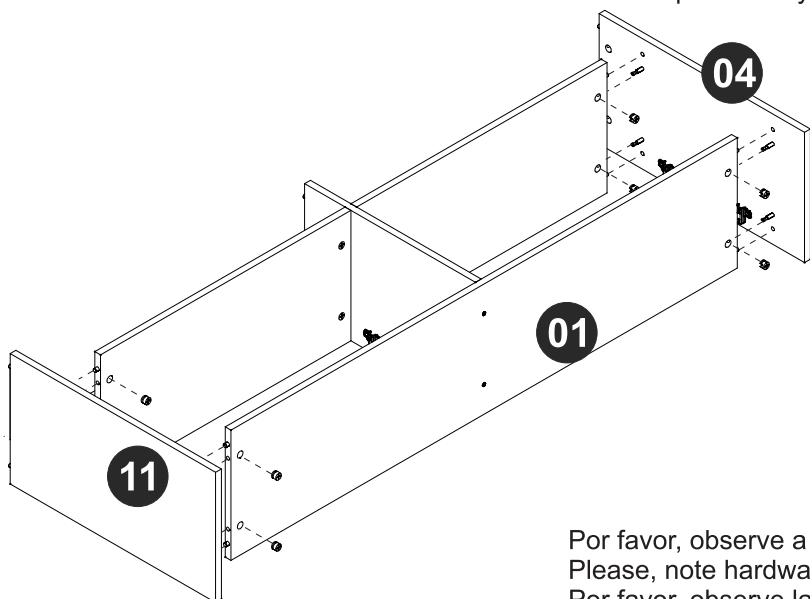

EF 000216

EF 000024

Por favor, observe a posição da ferragem EF 000024.  
Please, note hardware EF 000024 position.  
Por favor, observe la posición del herraje EF000024.

### PASSO 16 / STEP 16 / PASO 16

Conecte a peça 02, insira a ferragem EF 000216 e gire para apertar.  
Connect piece 02, insert hardware EF 000216 and turn to tighten.  
Junte la pieza 02, añade el herraje EF 000216 y gire para apretar.

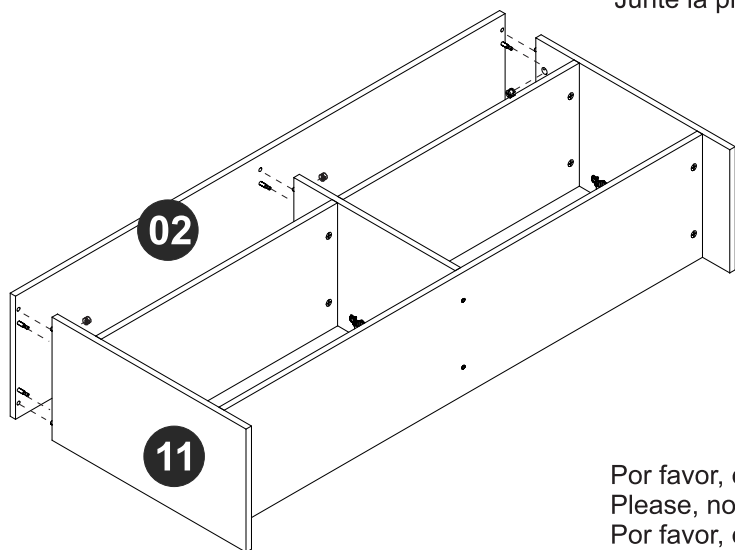

EF 000216

EF 000024

Por favor, observe a posição da ferragem EF 000024.  
Please, note hardware EF 000024 position.  
Por favor, observe la posición del herraje EF000024.

### PASSO 17 / STEP 17 / PASO 17

Fixe a peça 15 e os pés utilizando a ferragem EF 000168.  
Attach piece 15 and the feet using hardware EF 000168.  
Fije la pieza 15 y los pies utilizando el herraje EF 000168.

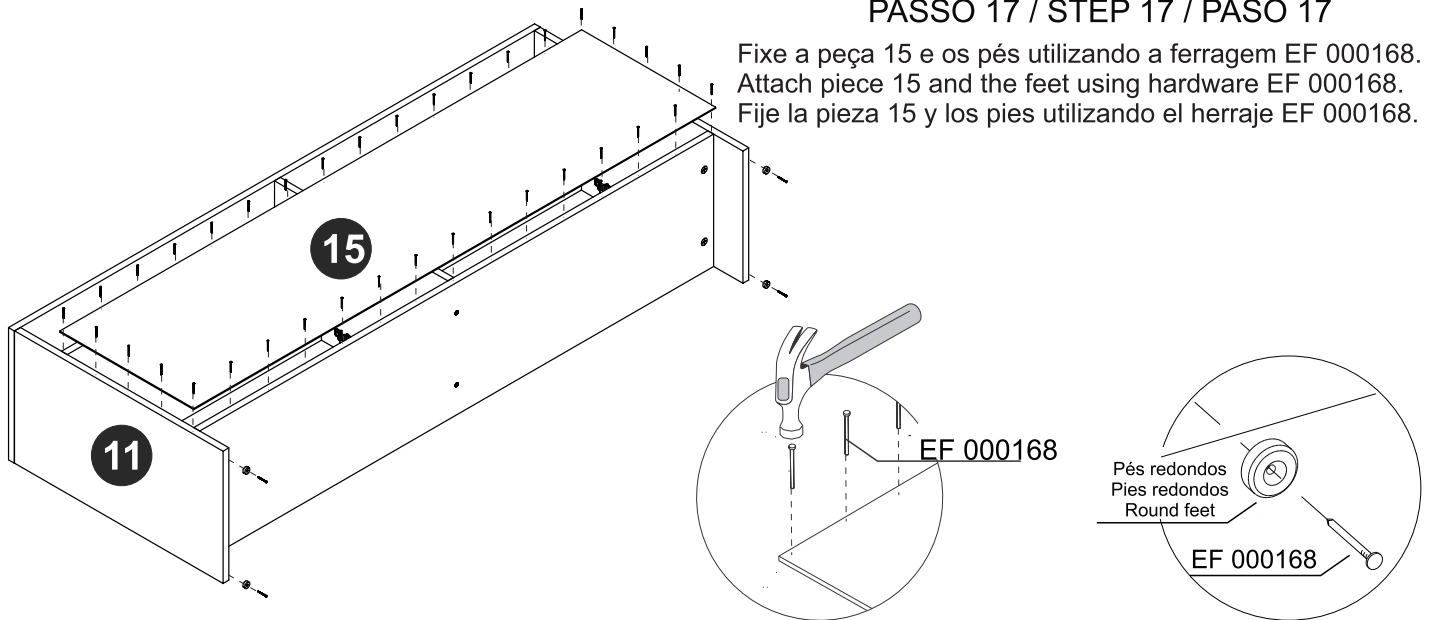

### PASSO 18 / STEP 18 / PASO 18

Fixe as peças 07 ao móvel montado.  
Fix pieces 07 at the assembled furniture.  
Fije las piezas 07 al mueble armado.

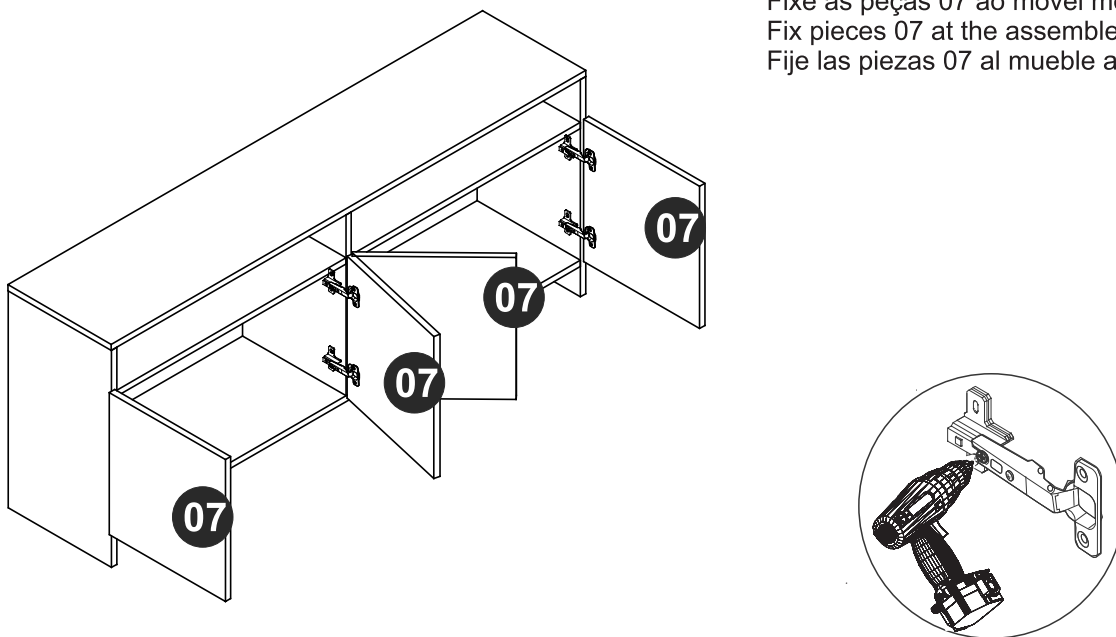

### PASSO 19 / STEP 19 / PASO 19

Use o giz para dar o acabamento final ao produto. Use os tapa furos para cobrir os parafusos aparentes.  
Use the chalk to give the final finish on the product. Use stickers to cover apparent screws.  
Utilice la tiza para dar el acabado final al producto. Utilice los tapa huecos para cubrir los tornillos aparentes.

