



**MANUAL DE MONTAGEM
ASSEMBLY INSTRUCTIONS
INSTRUCCIONES DE MONTAJE**

COD BR: BPP 01, BPP 111

Sumário Summary Resumen

Introdução Introduction Introducción	3
Antes de começar Before starting Antes de comenzar	4
Evite acidentes Avoid accidents Evitar accidentes	4
Dimensões e ferramentas Dimensions and tools Dimensiones y herramientas	5
Identificação das peças Identifying parts Identificación de las piezas	6
Acessórios incluídos na caixa Hardware included in box Accesorios incluidos en la caja	7
Montagem do móvel Furniture assembly Montaje del mueble	8

Introdução Introduction Introducción

Leia atentamente este manual e siga os passos indicados para que o produto não perca a garantia e também para uma perfeita montagem.

Read this manual and follow the steps in order to keep the guarantee and also for the perfect fit.

Lea este manual y siga los pasos para que el producto no pierda la garantía y también para el ajuste perfecto.

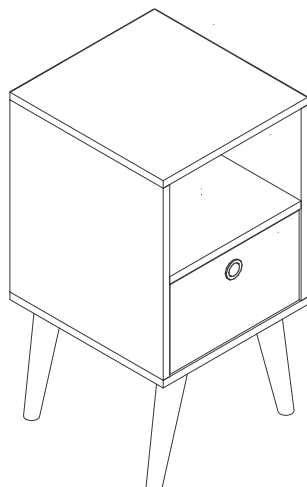

Antes de começar Before starting Antes de comenzar

Antes de começar a montagem prepare o ambiente, deixando-o completamente limpo e com bom espaço para iniciar o trabalho.

Prepare the room before starting the assembly, leaving it completely clean and the area in good condition to start the work.

Antes de comenzar el montaje preparar el ambiente, dejándolo completamente limpio y con bueno espacio para comenzar el trabajo.

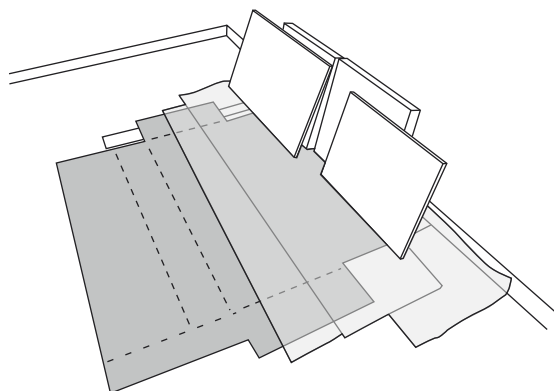

Utilize o papelão da própria embalagem para separar e apoiar as peças retiradas das caixas.

Use the cardboard of the packaging to separate and support the parts removed from the boxes.

Utilice el cartón de la embalaje para separar y apoyar las piezas desmontadas de las cajas.



Forre a área de montagem com um cobertor ou tapete. Assim, você evita avarias nas peças durante o processo de montagem.

Cover the assembly area with a blanket or carpet to avoid damaging the parts during the assembly process.

Cubrir la zona de ensamble con una manta o alfombra. De este modo, se evitan daños en las piezas durante el proceso de montaje.



Evite acidentes Avoid accidents Prevenir accidentes

Solicitamos observar atentamente as orientações de montagem como: fixação do produto na parede, colocação de cola em locais específicos necessários, o peso suportado pelo produto, etc...

We request you to carefully observe the assembly instructions as: fixing the product on the wall, adding glue in needed and specific places, product weight limit, etc.

Pedimos que lea atentamente las instrucciones, principalmente las informaciones de fijación del producto en la pared, colocación de pegamento en local específico y necesario, el peso soportado por el producto etc...

Não escale ou se apoie no móvel.

Do not climb or lean on the furniture.

No se suba ni se apoye en el mueble.

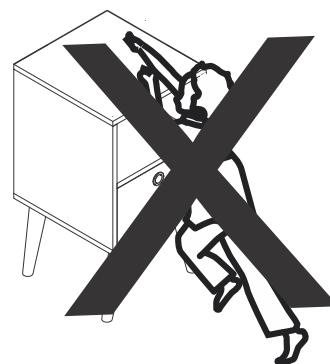

Dimensões e ferramentas
Dimensions and tools
Dimensiones y herramientas

Dimensões:

L: 330 A: 630 P: 350 mm

Dimensions:

W: 12.99 H: 24.8 D: 13.78 inches

Dimensiones:

L: 330 A: 630 P: 350 mm

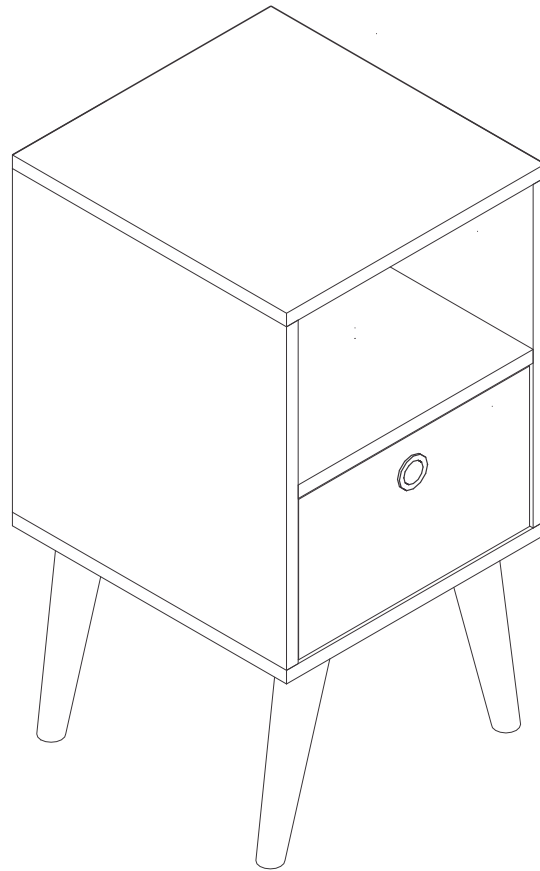

Limpeza
Cleanig
Limpieza

Pano levemente umedecido com água, seguido de pano seco, não utilizar produtos químico ou abrasivos.
Slightly dampened cloth and after a dry cloth, do not use chemicals or abrasives.
Solamente utilizar un paño húmedo y después un paño seco, no utilice productos químicos o abrasivos.

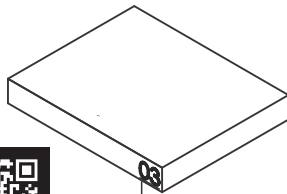

UTILIZE ALCOOL APENAS PARA REMOVER O NUMERO DAS PEÇAS
USE ALCOHOL ONLY TO REMOVE PART NUMBERS
UTILICE ALCOHOL SOLAMENTE PARA ELIMINAR EL NUMERO DE LAS PIEZAS

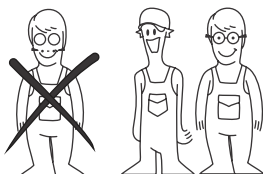

Para facilitar a montagem, utilize uma parafusadeira elétrica.
To improve assembly, use an eletronic screwdriver.
Para facilitar el armado, utilice un destornillador eléctrico.

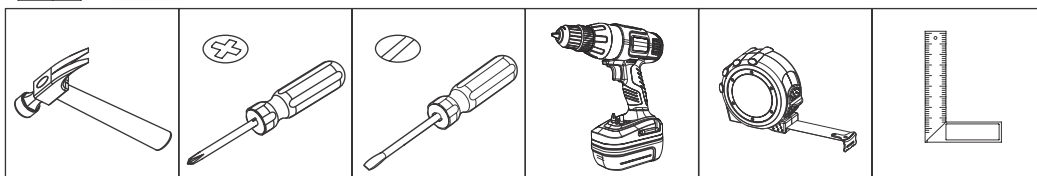

COD BR: BPP 01, BPP 111

PEÇA	DESCRIÇÃO	QUANT.
001	TAMPO	1
002	LATERAL DIREITA	1
003	FRENTE GAVETA	1
004	PÉS	4
006	PRATELEIRA	1
007	LATERAL ESQUERDA	1
008	FUNDO GAVETA	1
009	BASE	1
010	COSTA	2
020	LATERAL DIREITA GAVETA	1
021	COSTA GAVETA	1
022	LATERAL ESQUERDA GAVETA	1

PART	DESCRIPTION	QTY
001	TOP	1
002	RIGHT SIDE	1
003	FRONT DRAWER	1
004	WOOD FEET	4
006	SHELF	1
007	LEFT SIDE	1
008	DRAWER BOTTOM	1
009	BASE	1
010	BACK	2
020	RIGHT SIDE DRAWER	1
021	DRAWER BACK	1
022	LEFT SIDE DRAWER	1

PIEZA	DESCRIPCIÓN	CANTIDAD
001	TAPA	1
002	LATERAL DERECHA	1
003	FRENTE CAJÓN	1
004	PIES	4
006	ESTANTE	1
007	LATERAL IZQUIERDA	1
008	FONDO CAJÓN	1
009	BASE	1
010	REVÉS	2
020	LATERAL DERECHA CAJÓN	1
021	REVÉS CAJÓN	1
022	LATERAL IZQUIERDA CAJÓN	1

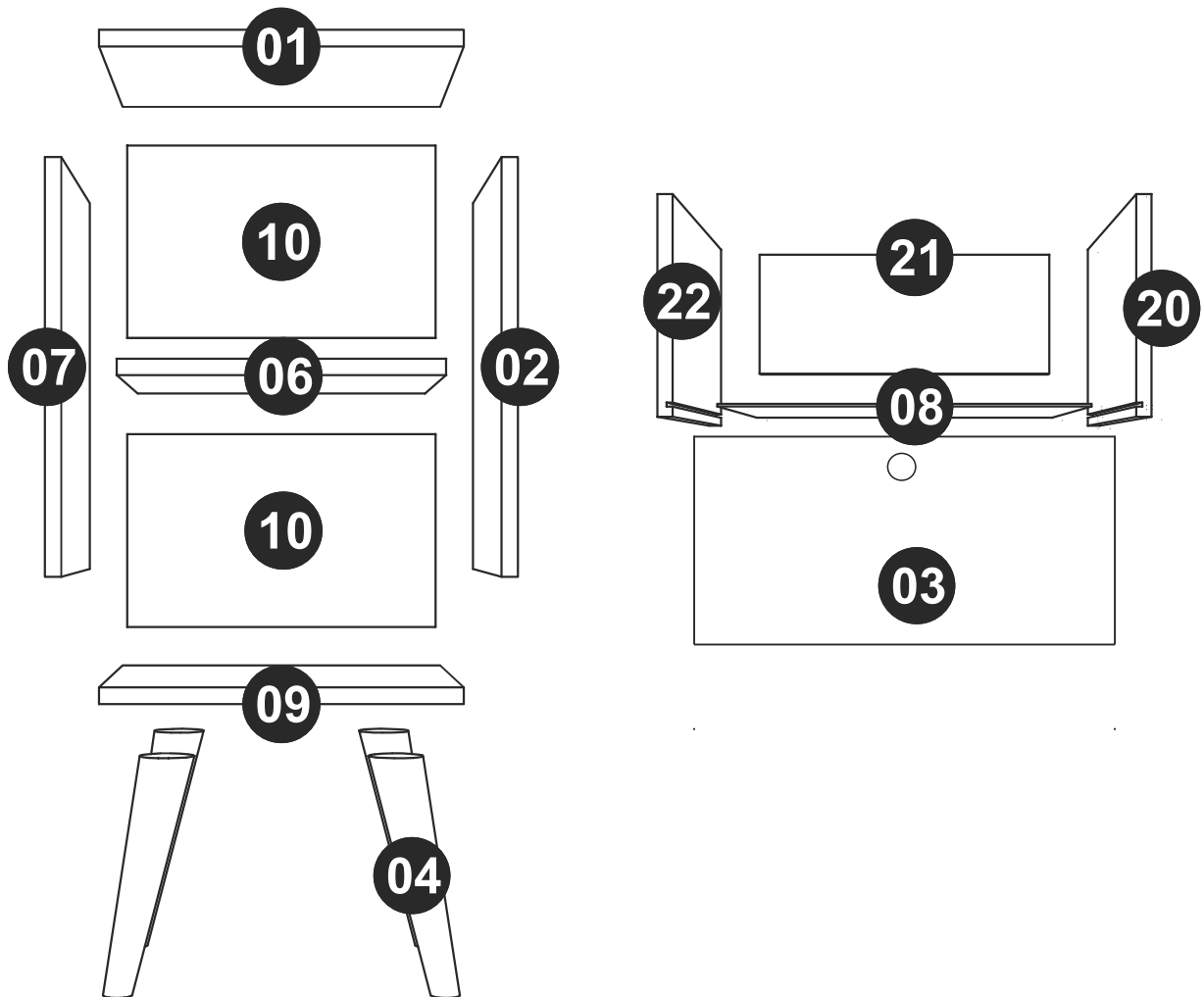

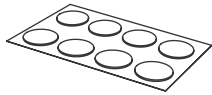

TAPA FUROS x 8
STICKER x 8
TAPAS PLÁSTICAS x 8



EF 000745 x 4
5X40



EF 000216 X 8



EF 000033 x 20
8x30

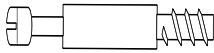

EF 000094 X 8



EF 000132 x 4
4X50 CC



EF 000168 X 20
10X10 C/C



GIZ x 01
CHALK x 01
TIZA x 01

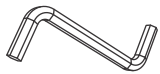

EF 000741 x 1

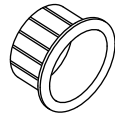

PUXADOR x 1
HANDLE x 1
MANIJA x 1

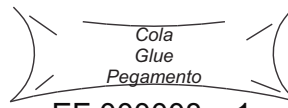

EF 000008 x 1



CORREDIÇAS x 2
DRAWER TRACKS x 2
CORREDERAS x 2



EF 000106 x 8
3,5X14 CC

Utilize para medir as ferragens.

Utilice para medir el herraje.

Use for measuring the hardware.

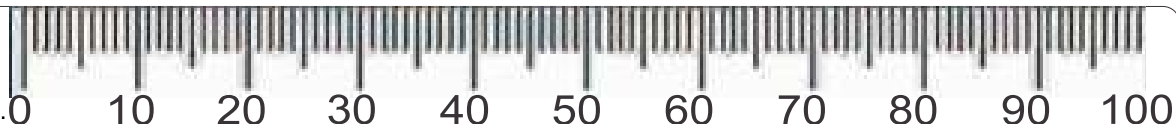

Garantia (exclusivo para o Brasil/exclusivo de Brasil/exclusive to Brazil):

A garantia dos produtos fabricados pela BRV Móveis, abrange eventuais defeitos-vícios de fabricação, no prazo estabelecido pelo código de Defesa do Consumidor, em seu artigo 26.II. o qual prevê a garantia de 90 (noventa) dias.

A = 3 KG - 6.61LB

B = 2 KG - 4.41LB

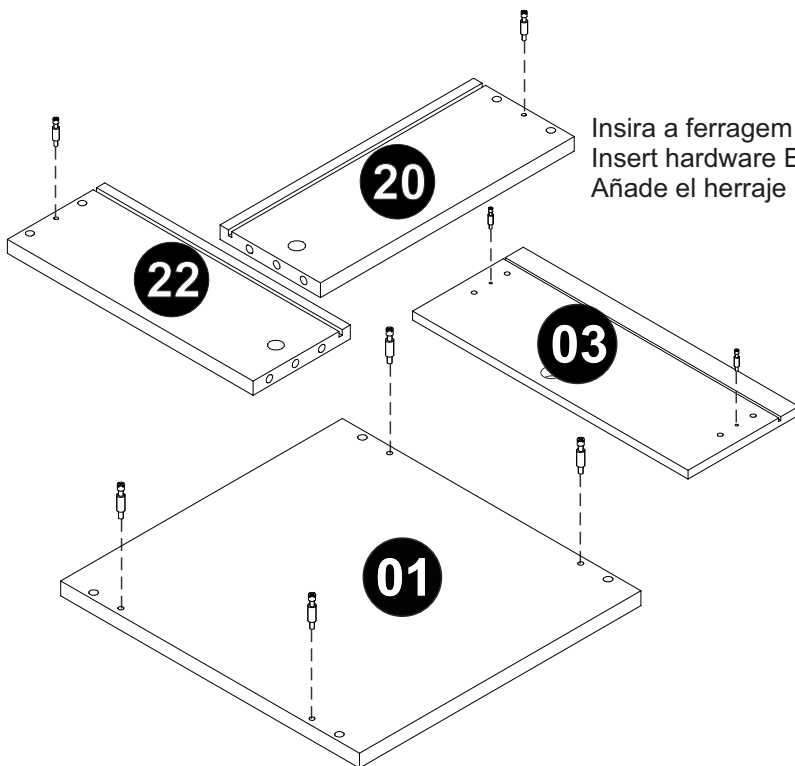
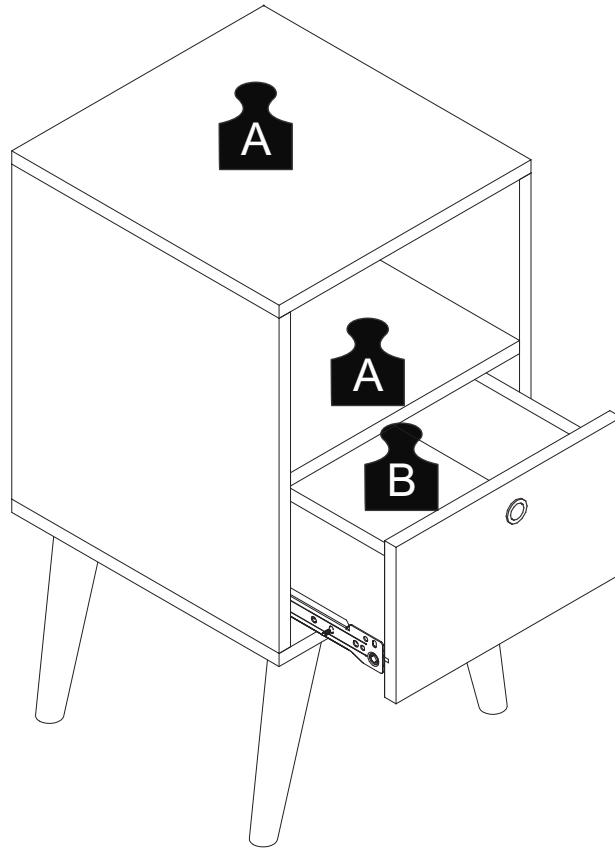

PASSO 1 / STEP 1 / PASO 1

Insira a ferragem EF 000094 nas peças 01, 03, 20 e 22.
Insert hardware EF 000094 into pieces 01, 03, 20 and 22.
Añade el herraje EF 000094 en las piezas 01, 03, 20 y 22.

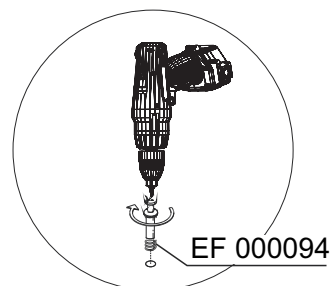

PASSO 2 / STEP 2 / PASO 2

Insira a ferragem EF 000033 nas peças 02, 06 e 07. Fixe as corrediças utilizando a ferragem EF 000106.
Insert hardware EF 000033 into pieces 02, 06 and 07. Attach the drawer tracks using hardware EF 000106.
Añade el herraje EF 000033 en las piezas 02, 06 y 07. Fije las correderas utilizando el herraje EF 000106.

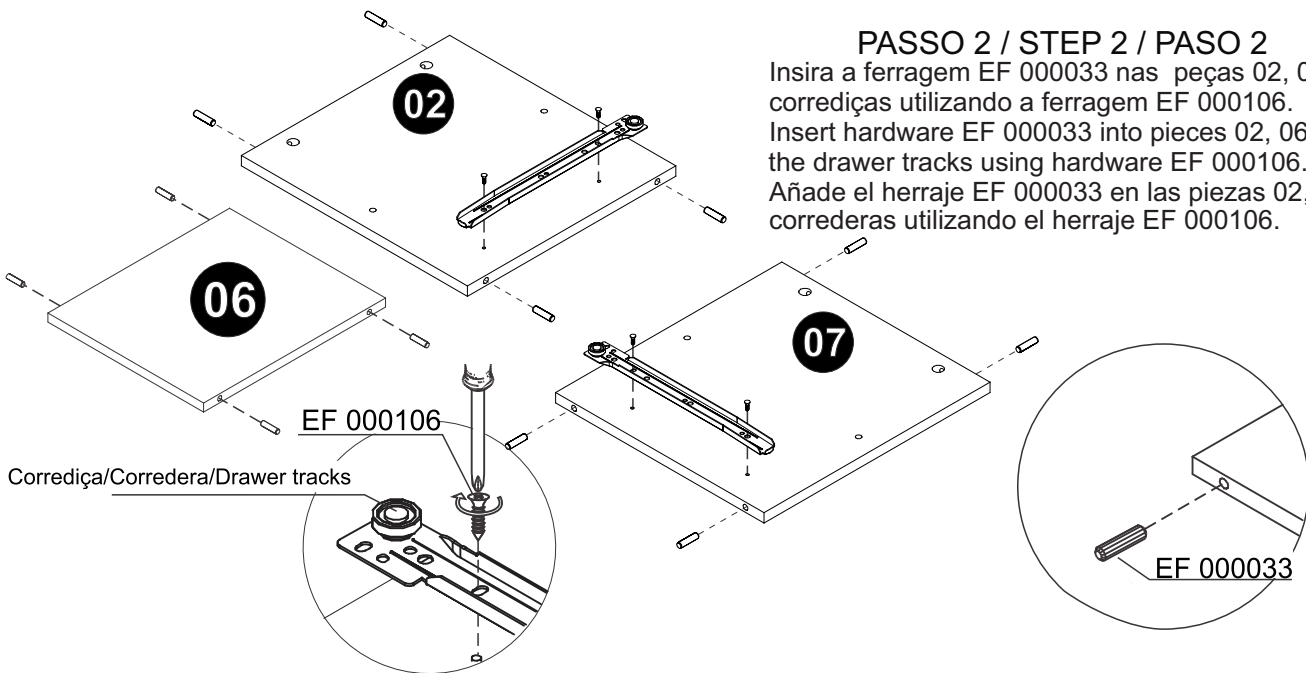

PASSO 3 / STEP 3 / PASO 3

Insira a ferragem EF 000033 nas peças 20, 21 e 22.
Insert hardware EF 000033 into pieces 20, 21 and 22.
Añade el herraje EF 000033 en las piezas 20, 21 y 22.

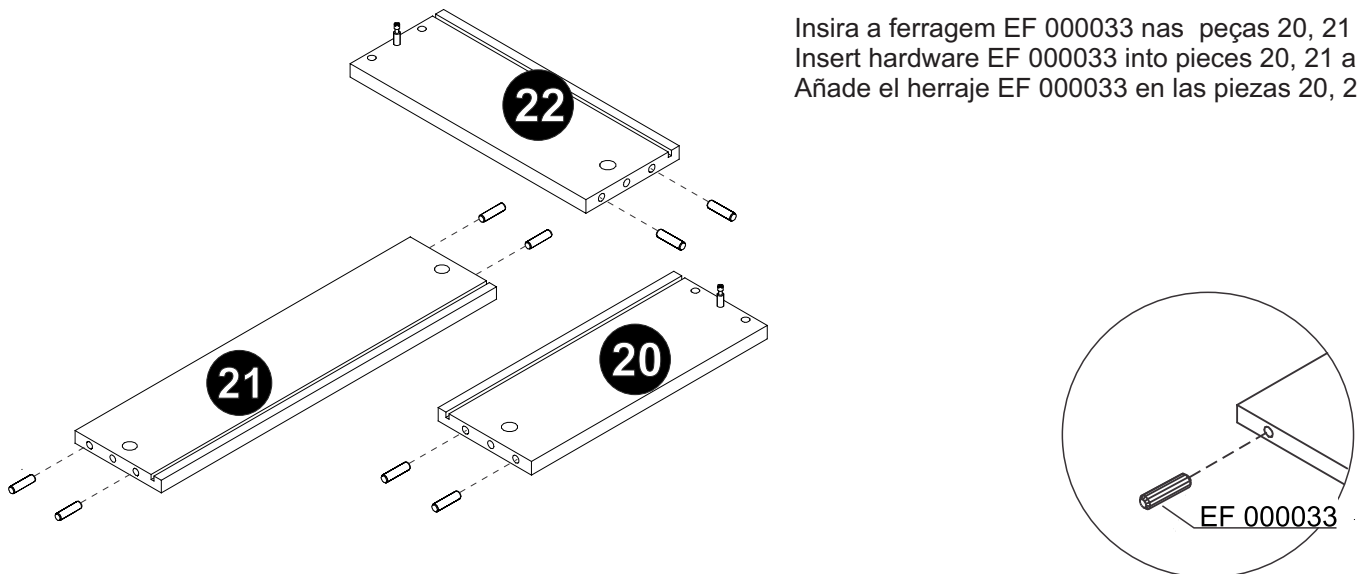

PASSO 4 / STEP 4 / PASO 4

Use a cola (EF 000008) antes de conectar as peças 02, 06 e 07.
Use the glue (EF 000008) before connecting pieces 02, 06 and 07.
Utilice el pegamento (EF 000008) antes de juntar las piezas 02, 06 y 07.

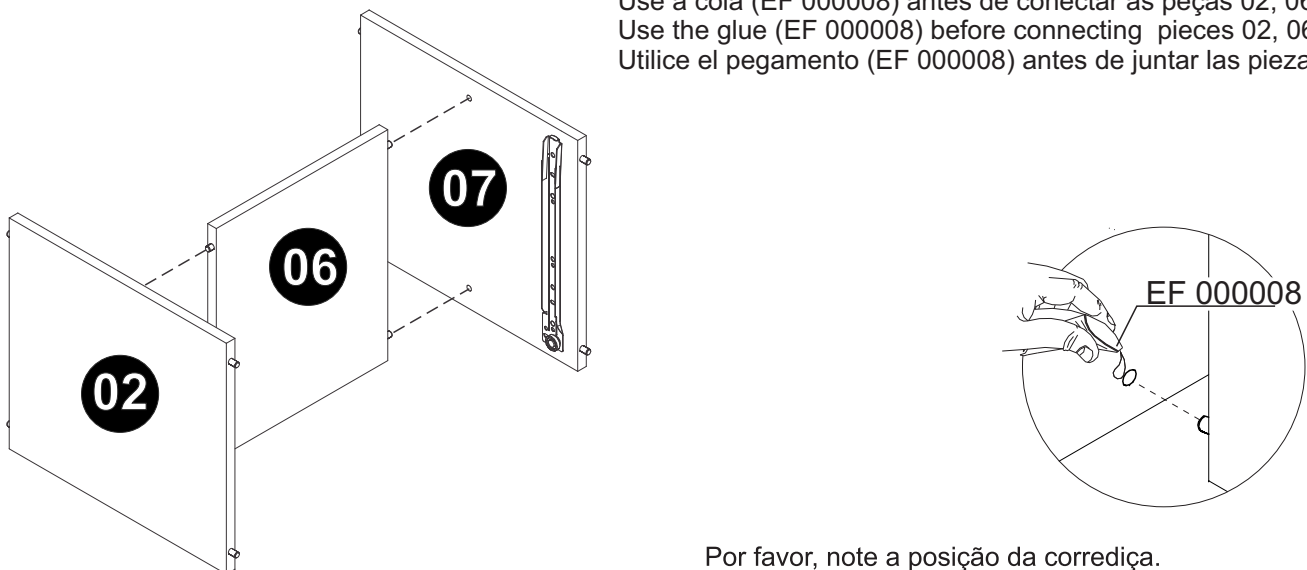

Por favor, note a posição da corrediça.
Please, note the drawer tracks position.
Por favor notar la posición de las correderas.

PASSO 5 / STEP 5 / PASO 5

Fixe os pés (peças 04) na peça 09 usando a ferragem EF 000745 e EF 000741.

Fix the feet (pieces 04) at piece 09 using hardware EF 000745 and EF 000741.

Fije los pies (piezas 04) en la pieza 09 utilizando los herrajes EF000745 y EF 000741.

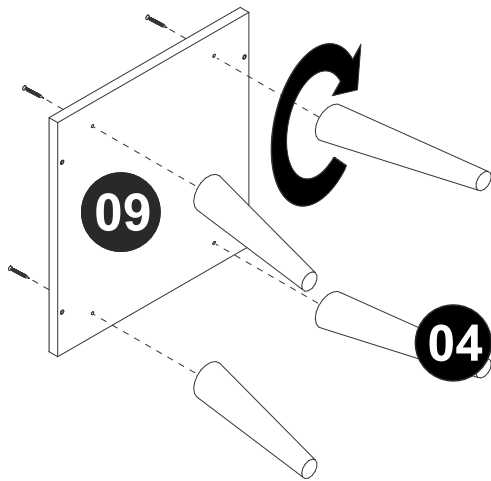

EF 000741

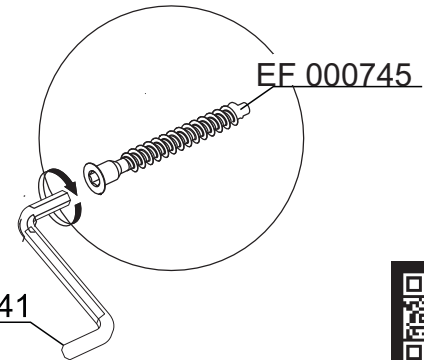

PASSO 6 / STEP 6 / PASO 6

Fixe as partes montadas nos passos 4 e 5 utilizando a ferragem EF 000132. Conecte a peça 01, insira a ferragem EF 000216 e gire para apertar.

Fix parts assembled on step 4 and 05 using hardware EF 000132. Connect piece 01, insert hardware EF 000216 and turn to tighten.

Fije las partes armadas en los pasos 4 y 5 utilizando el herraje EF 000132. Fije la pieza 01, inserte el herraje EF 000216 y gire para apretar

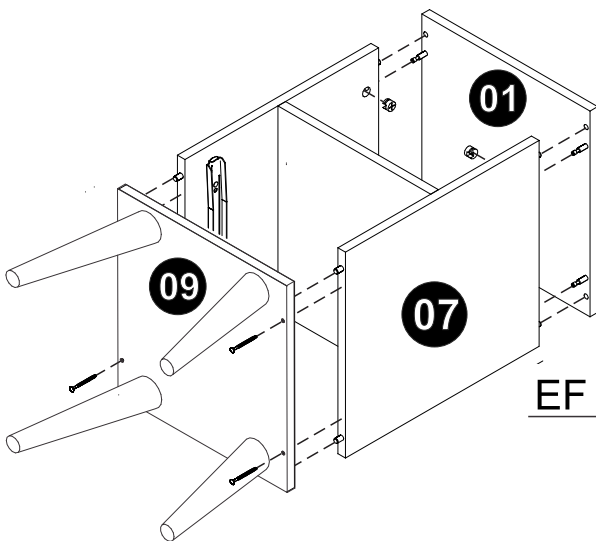

EF 000132

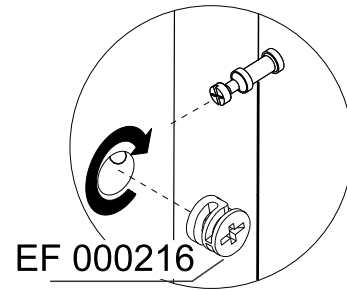
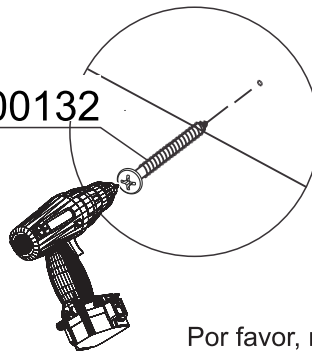

EF 000216

Por favor, note a posição da corredeira.
Please, note the drawer tracks position.
Por favor notar la posición de las correderas.

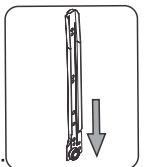

PASSO 7 / STEP 7 / PASO 7

Fixe as peças 10 ao móvel utilizando a ferragem EF 000168.

Fix pieces 10 at the furniture using hardware EF 000168.

Fije las piezas 10 al mueble utilizando el herraje EF 000168.

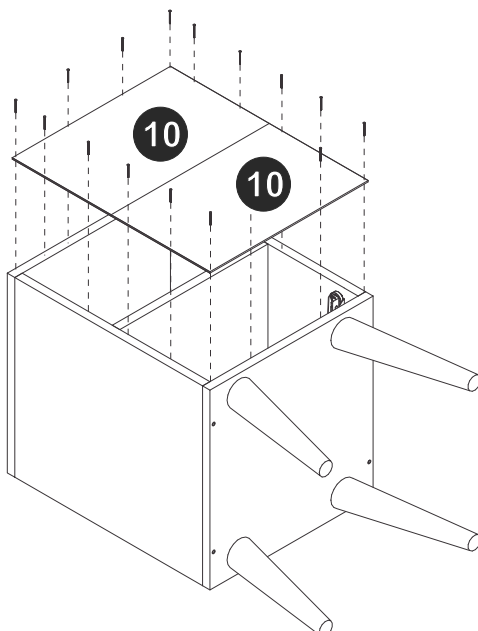

EF 000168

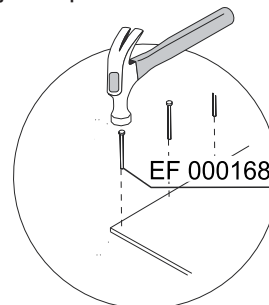

Por favor, note a posição da corredeira.
Please, note the drawer tracks position.
Por favor notar la posición de las correderas.

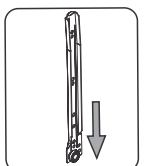

PASSO 8 / STEP 8 / PASO 8

Conecte as peças 20, 21 e 22, insira e gire a ferragem EF 000216 até apertar
Connect pieces 20, 21 and 22 fitting hardware EF 000216 and EF 000094, turn hardware EF 000216 to tighten.
Junte las piezas 20, 21 y 22. Añade y gire el herraje EF000216 hasta apretar.

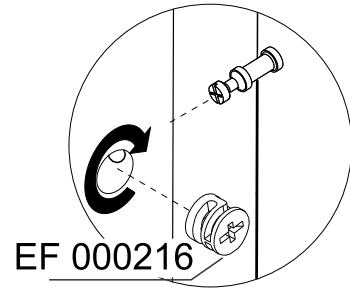
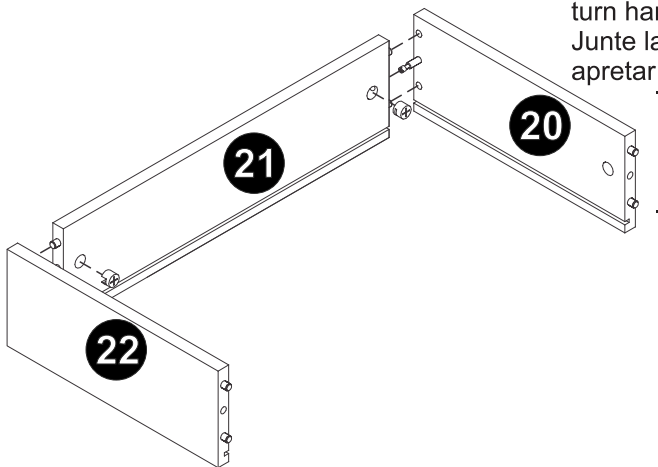

PASSO 9 / STEP 9 / PASO 9

Encaixe a peça 08 entre os espaços específicos nas peças 20 e 22.
Fix piece 08 at part assembled through the specific spaces in pieces 20 and 22.
Fije la pieza 08 entre los espacios específicos en las piezas 20 y 22.

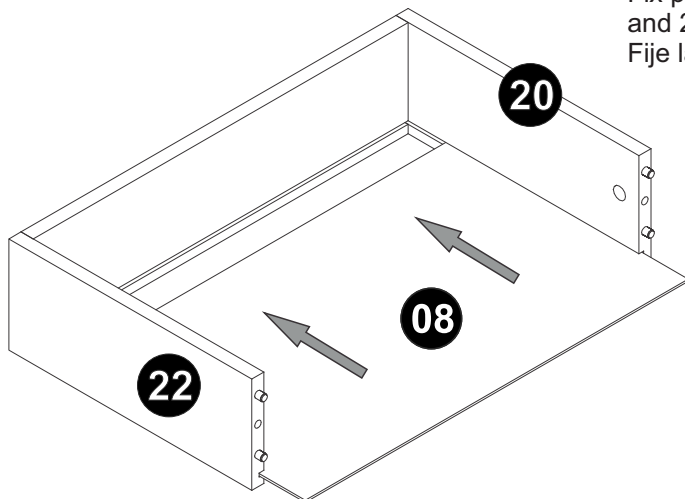

PASSO 10 / STEP 10 / PASO 10

Insira a ferragem EF 000216 na peça 03 e gire para apertar.
Insira o puxador no local indicado.
Insert hardware EF 000216 into piece 03 and turn to tighten.
Insert the handle in the indicated place.
Añade el herraje EF 000216 en la pieza 03 y gire para apretar.
Añade la manija en el local indicado.

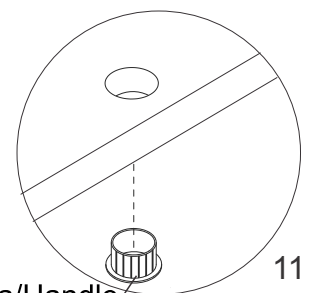
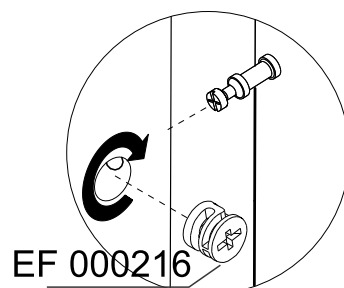
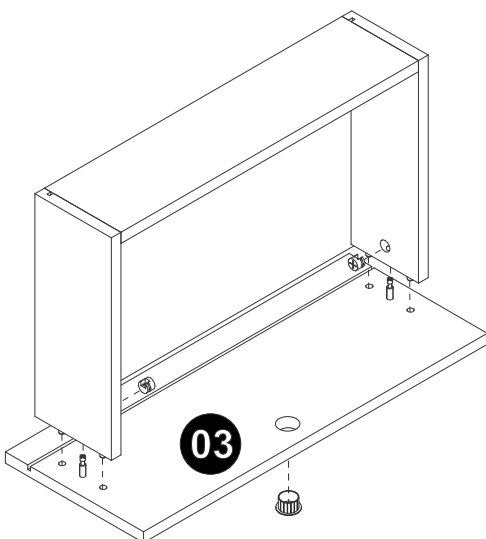

Puxador/Manilla/Handle

PASSO 11 / STEP 11 / PASO 11

Fixe as corrediças utilizando a ferragem EF 000106.
Attach the drawer tracks using hardware EF 000106.
Fije las correderas utilizando el herraje EF 000106.

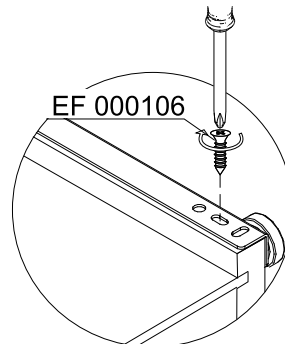
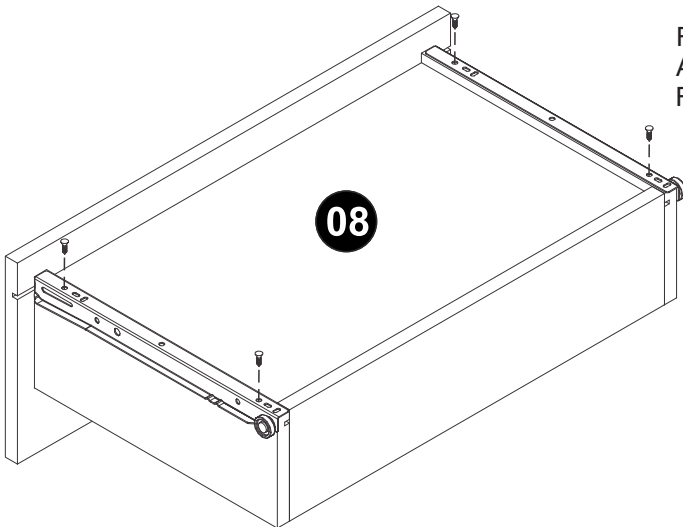

PASSO 12 / STEP 12 / PASO 12

Use os tapa furos para cobrir os parafusos aparentes.
Use stickers to cover apparent screws.
Utilice los tapa huecos para cubrir los tornillos aparentes.

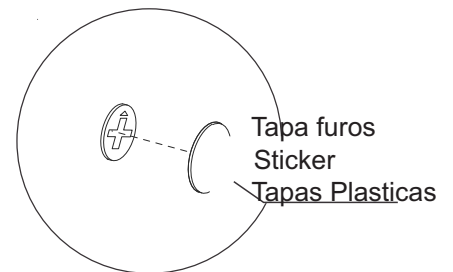
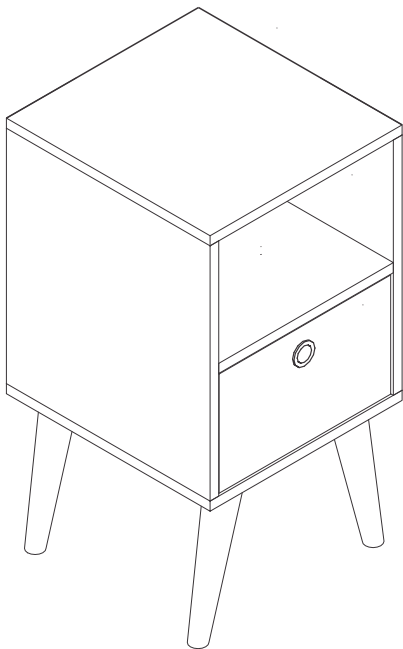

PASSO 13 / STEP 13 / PASO 13

Use o giz para dar o acabamento final ao produto.
Use the chalk to give the final finish on the product.
Utilice la tiza para dar el acabado final al producto.

